

INSTALLATION, OPERATING AND MAINTENANCE

R32



AIR COOLED LIQUID CHILLER - HEAT PUMP

eCOMFORT R32



35 - 210 kW

MIL166E-0222 09-2024



www.lennoxemea.com

LENNOX

AIR COOLED UNITS

INSTALLATION, OPERATION, MAINTENANCE MANUAL



Ref.: MIL166E-0222 09-2024

The present manual applies to the following chiller versions:

eComfort range:

- GAC-GAH 035-210 (BASIC UNITS)
- GBC-GBH 040-210 (ADVANCED UNITS)

INSPECTIONS AND REQUALIFICATION ACCORDING PRESSURE EQUIPMENT DIRECTIVE MUST FOLLOW THE LOCAL REGULATIONS WHERE THE UNIT IS INSTALLED.

<p>Our company is a member of the Eurovent Certification Program, all LENNOX chillers are tested and rated in accordance with Eurovent certification program.</p>	
<p>Our products comply with the European standards.</p>	

Original version is the English one. Other versions are translations.

All the technical and technological information contained in this manual, including any drawing and technical descriptions provided by us, remain the property of LENNOX and must not be utilised (except in operation of this product), reproduced, issued to or made available to third parties without the prior written agreement of LENNOX.

TABLE OF CONTENTS

	Page
INTRODUCTION	4
COMPLIANCE WITH REGULATIONS AND DIRECTIVES	5
MAIN SAFETY RECOMMENDATIONS	6 - 7
WARRANTY	8 - 9
WARNING	10 - 11
FLAMMABLE GASES	12 - 14
DATA PAGE FOR UNIT COMMISSIONING	15
1. GENERAL CHARACTERISTICS	
1.1 Technical data	16 - 24
1.2 Component	24 - 25
1.3 Operation limits	26 - 27
1.4 Hydraulic system data	28 - 31
1.5 Pressure drop in the water system	32 - 33
1.6 Water flow	34 - 35
1.7 Piping drawings	36 - 55
1.8 Dimensions	56 - 68
2. INSTALLATION	
2.1 Transport-Handling	69 - 71
2.2 Site and shipping guidance	71
2.3 Unit lifting	71
2.4 Antivibration mounting	72
2.5 Weight distribution	73 - 78
2.6 Installation clearances	79 - 81
2.7 Unit installation	82 - 84
2.8 Electrical connections	85 - 90
2.9 Option: Partial Heat Recovery	91
3. COMMISSIONING AND OPERATION	
3.1 Steps to follow for commissioning the units	92 - 93
3.2 Unit operation: Refrigerant circuit	94
3.3 Unit operation: Electrical and control features	94
3.4 Climatic control	94
3.5 Checking the water flow rate	95
3.6 Water analysis	96

4. MAINTENANCE	97
4.1 Preventive maintenance	98
4.2 Maintenance plan	99 - 101
4.3 Cleaning the condenser	102 - 103
4.4 Process for replacing a compressor on field	104
4.5 Corrective maintenance	105
4.6 Refrigerant emission control	106
4.7 Compressor maintenance	106 - 108
4.8 Disposal of equipment	109
4.9 Pressure relief valves	109
5. END OF THE MACHINE LIFE	109
6. TROUBLESHOOTING - REPAIRS	
6.1 List of the most common problems	110 - 113
6.2 Control devices	114
6.3 Regular checks to be made: Chiller unit environment	115
6.4 Manufacturer's recommended inspections	116
7. CHECK LIST	117 - 118

INTRODUCTION

We remind you that these instructions must be followed for operation, maintenance, repair and decommissioning of the product. Failure to follow these instructions will result in the offender assuming the manufacturer's responsibilities.

You must read and be familiar with this operating manual prior to commission the chiller.

Please closely follow the instructions.

We would like to stress the importance of training with respect to the correct handling of the chiller.

Please consult LENNOX on the options available in this field.

It is important that this manual is stored in a permanent location in the vicinity of the chiller.



IMPORTANT GENERAL INSTRUCTIONS

This manual contains important instructions regarding the commissioning of the chiller. It also includes important instructions to prevent personal injury and damage to the machine during operation. Furthermore, in order to promote fault-free operation of the chiller, maintenance information has been included.

Please do not hesitate to contact one of our employees should you require further information on specific chiller subjects. Order related documentation will be forwarded under separate cover.

This documentation consists of:

- **EU declaration.**
- **Operating manual for control system.**
- **Installation operating manual.**
- **Wiring diagram.**
- **Refrigerant flow diagram.**
- **Units detail are given on unit nameplate.**

The data published in this manual is based on the most recent information available. It is supplied conditional to later modifications. We reserve the right to modify the construction and/or design of our chillers, at any time, without prior notification or obligation to adapt previous supplies accordingly..



Any work on the Chiller should be carried out by trained and licensed competent technician. The following risks are present on the unit:

- **Risk of electrical shock.**
- **Risk of injury from rotating parts.**
- **Risk of injury from sharp edges and heavy weight.**
- **Risk of injury from high pressure gas.**
- **Risk of injury from slightly flammable refrigerant.**
- **Risk of injury from high and low temperatures components.**

It is expected that all works on equipment be carried out in accordance with all local standards and norms. It is expected that all works are carried out with good working practices.

Inspections and requalification according to Pressure Equipment Directive (PED) must follow the local regulations where the unit is installed.

The refrigerating system is designed for a working life of at least 12 years if the safety and maintenance instructions are strictly respected.

The equipment can be renewed in its lifespan of the periodic requalification certificate is validated by the expert (Authorized body or according to current local regulations).

COMPLIANCE WITH REGULATIONS AND DIRECTIVES

The units comply with the directives and regulations which apply at the time of their placing on the market. For more information, please see the product's Declaration of Conformity.

The unit is designed for outdoor installation only. The unit must be installed in accordance with local safety codes and regulations and can only be used in well ventilated area.

Inspections and requalification according to the pressure equipment directive must comply with the regulations of the place where the unit is installed. In some countries there may be mandatory requirements for commissioning, operational monitoring, periodic inspection and requalification. Please refer to them when installing the equipment. In France, the ministerial decree of 20/11/2017 (or formerly the decree of March 15, 2000) relating to the in-service monitoring of pressure equipment and simple pressure vessels applies. By respecting the CTP of the USNEF entitled: "Professional technical book for the monitoring in service of pressurized refrigeration systems" your refrigeration system will be in conformity with the ministerial decree.

We would like to stress the importance of training with respect to the correct handling of the unit. Please consult LENNOX on the options available in this field.

It is important that this manual is stored in a permanent location in the vicinity of the unit.

SAFETY DEVICES:

This equipment is protected with calibrated safety pressure switches.

PRESSURE RELIEF VALVES:

This equipment contains pressure relief valves to limit damage in the event of an external fire. Make sure that people are not exposed to refrigerant discharge.

EMC DIRECTIVE COMPLIANCE

WARNING:

This equipment is compliant with the essential requirements of the EMC2014/30/EU directive for industrial environments and light industry. In an industrial environment, this equipment may create radio noise. In this case, the owner can be asked to take appropriated actions.

The units meet the following hardest environments standards, according to the product's Declaration of Conformity:

- EN 61000-6-2 : Immunity for industrial environments.
- EN 61000-6-4 : Emissions for industrial environments.
- EN 61000-6-8 : Emissions for commercial and light industrial environments.

In conclusion, in view of the results obtained on the unit tested, the entire range defined complies with the essential requirements of the EMC Directive 2014/30/EU, for commercial, light industrial and industrial environments in accordance with the above standards.

This applies to all installed machines which have a rated current $I < 75A$:

- The short-circuit ratio $R_{sce}=66$ is defined in standard EN61000-3-12 in relation to the harmonic values on the network. Equipment complying with the harmonic current limits equivalent to $R_{sce}=66$ may be connected to any connection point on the main power supply system.
- The machine also complies with EN 61000-3-11. Tests show no limits are exceeded and no specific Z_{max} is required for voltage variation, fluctuation, and flicker measurements. The connection to the supply is a conditional connection submitted to the preliminary agreement of the power supply local provider.

The differences between the various machines are only related to the power of the compressors and equipment that are associated. For conducted and radiated emission and immunity, these differences do not alter the results.

CAUTION:

In the event of fire, refrigerating circuits can cause an explosion and spray coolant gas and oil.

F-GAS REGULATION:

PLEASE READ THE SAFETY DATA SHEET OF THE REFRIGERANT BEFORE ANY INTERVENTION OR INSTALLATION OF THE UNIT.

Operators of refrigeration equipment's must comply with the obligations defined in:

- Regulation on Fluorinated greenhouse gases (F Gas).
- Regulation on substances that deplete the ozone layer.

	<p>Non compliance with these requirements is an offence and liable of financial penalties.</p>
	<p>Moreover, in case of problem it is mandatory to prove to the insurance company that the equipment complies with the F gas Regulation, as well as that all measures have been taken to safeguard people, environment and property.</p>

MAIN SAFETY RECOMMENDATIONS



IMPORTANT NOTICE:

All work on the unit must be carried out by a qualified and authorized personnel.
Non-compliance with the following instructions may result in injury or serious accidents.

Protection: Safety accessory / Damage limitation accessory:

In the chillers, the HP pressure switch is a PED safety accessory (see 2.11 Dir.2014/68/EU) and the valves are accessories to limit damage in the event of an external fire (see 2.12).

	PED safety accessory (see 2.11)	Damage limitation accessory in the event of an external fire (see 2.12)
HP pressure switch	YES	N/A
Valve(s)	N/A	YES

Safety pressure switch chain test:

Test to check correct operation of the safety pressure switch chain, to be carried out every year by Lennox technical personnel.

- Before starting the test, install an HP pressure gauge to check overall operation of the safety pressure switch. Perform a visual check and a preliminary leak test.
- Start the Climatic's "Circ1 HP or Circ2 HP" mode to build up pressure in the refrigerant circuit (compressors running, ventilation off, program HP envelope safety deactivated, pressure switch contactor status taken into account).
- When the pressure switch is switched on, the contactor is deactivated, shutting down the compressors and activating alarm 091.
- Check on the Climatic display that the pressure trip value is less than PS.

Works on the unit:

The risk analyses of our machines are carried out considering operation in a standard environment with unpolluted air. For other applications, which do not meet this criterion (Kitchen, industry, ...) please contact your local sales representative.

- The unit shall be isolated from the electrical supply by disconnecting and locking out the main isolating switch.
- Workers shall wear the appropriate personal protective equipment (helmet, gloves, glasses, etc.).

Works on the electrical system:

- Work on electric components shall be performed with the power off by employees having valid electrical qualification and authorization.

Work on the refrigerant circuit(s):

- Monitoring of the pressures, draining and filling of the system under pressure shall be carried out using equipment designed for this purpose and suitable for the refrigerant contained.
- To prevent the risk of explosion due to spraying of coolant and oil, the relevant circuit shall be drained and at zero pressure before any disassembly or unbracing of the refrigerating parts takes place.
- There is a residual risk of pressure build-up by degassing the oil or by heating the exchangers after the circuit has been drained. Zero pressure shall be maintained by venting the drain connection to the atmosphere on the low-pressure side.
- The brazing shall be carried out by a qualified brazier. The brazing shall comply with standard EN1044 (minimum 30% silver).

Replacing components, equipment and piping:

- Replacement shall be carried out using spare parts, or using parts approved by LENNOX.
- Only the refrigerant shown on the manufacturer's nameplate shall be used, excluding the rest of the products (mixture of refrigerants, hydrocarbons, etc.).

Parametering and control:

- For any intervention related to component parameterization, controls and unit operation management, refer to "eClimatic" user manual.

MAIN SAFETY RECOMMENDATIONS

Recommend refrigerant speeds:

- Liquid: Max. pressure loss: 1 - 1,5°C. Max. speed: 1 - 1,5m/s.
- Suction: Max. pressure loss: 1,5 - 2°C. Vmax: 15m/s, Vmin horizontal: 3,5m/s, Vmin vertical: 8m/s.
- Delivery: Max. pressure loss: 1°C. Vmax: 15m/s, Vmin horizontal: 3,5m/s, Vmin vertical: 8m/s

Transport - Handling:

- Never lift the unit without forklift protections.
- Remove the forklift protection before installation.
- If access to the installation is difficult, provide guard rail. This recommendation is valid for installations in general. It's also valid to reach other parts of the unit: refrigerant circuit, etc.
- Installation of the unit and accessibility must be compliant with the local regulations. Ensure that all access equipment allow maintenance operation in safety (electrical cabinet, main switch, panels, refrigerant circuit, etc).
- It is strictly forbidden to walk or store equipment or material on top of the unit.
- Equipment designed to withstand transport and handling according to the established protocol (for the handling protocol, please refer to the installation instructions for the relevant product range).
- All unloading operations must be carried out with suitable equipment (crane, forklift truck, etc.).
- When using a forklift truck, you must respect the positions and the direction of handling indicated on the products.
- The equipment must be handled with care to avoid damage to the bodywork, pipework, condenser, etc.

Unit installation in heavy wind locations:

- The units are designed to withstand winds up to 80km/h. Above this limit, it's recommended to take appropriate actions to secure the installation.

Commissioning:

- It must only be carried out by trained refrigeration engineers.
- Don't forget to open the insulation valve on the liquid line before starting the unit.

WARNING:

- **The units are not designed to resist to a fire. The installation site must comply with the standards relating to fire protection.**
- **In case of installation of the units in an area recognized as being potentially at risk for natural phenomena (tornado, earthquake, tidal wave, lightning...), please follow the standards and regulations, and provide the necessary devices to prevent from these risks.**
- **In the event of fire, refrigerating circuits are liable to rise in pressure above the maximum working pressure and release refrigerant and oil. Please take this into account in your risk analyses.**

Delivery checks:

On receipt of a new equipment please check the following points. It is the customer's responsibility to ensure that the products are in good working order:

- The exterior has not been damaged in any way.
- The lifting and handling equipment are suitable for the equipment and comply with the specifications of the handling instructions enclosed here-in.
- Accessories ordered for on-site installation have been delivered and are in good working order.
- The equipment supplied corresponds to the order and matches the delivery note.

If the product is damaged, exact details must be confirmed in writing by registered post to the shipping company within 48 hours of delivery (working days). A copy of the letter must be addressed to LENNOX and the supplier or distributor for information purposes. Failure to comply will invalidate any claim against the shipping company.

Storage:

When units are delivered on site they are not always required immediately and are sometimes put into storage. In the event of medium to long-term storage, we recommend the following procedures:

- Ensure that there is no water in the hydraulic systems.
- Keep protective plastic film in position.
- Ensure the electrical panels are closed.
- Keep all items and options supplied in a dry and clean place for future assembly before using the equipment.
- Store the unit on an appropriate place (flat surface).
- Storage temperature must be respected according to the information given on the rating plate.

It is strongly recommended to store units in a dry, sheltered place (in particular for units that will be installed indoor).

WARRANTY

The warranty of the unit is subject to the warranty definitions as agreed upon in the order. It is expected that the design and installation of the unit utilises good working practices. The warranty will be legally null and void if:

- ***Service and maintenance have not been executed in accordance with the regulations; repairs have not been carried out by LENNOX personnel or have been implemented without prior written permission by LENNOX.***
- ***Modifications have been made to the equipment without prior written permission by LENNOX.***
- ***Settings and protections have been modified without prior written permission by LENNOX.***
- ***Non-original or other than the prescribed refrigerants or lubricants are used.***
- ***The equipment has not been installed and/or connected in accordance with the installation instructions.***
- ***The equipment is being used improperly, incorrectly, negligently or not in accordance with its nature and/or purpose.***
- ***A flow protection device is not fitted.***
- ***The unit maintenance booklet is not complete or not available.***

In these circumstances LENNOX is indemnified from any product liability claims from third parties. In the event of a warranty claim the machine serial number and LENNOX order number must be quoted.

The technical information and specifications contained in this manual are for reference only. The manufacturer reserves the right to modify these without warning and without obligation to modify equipment already sold.



DO NOT CONFUSE THE WARRANTY WITH MAINTENANCE.

In the absence of any other written agreement (e.g. local regulations), the guarantee shall only apply to design faults which occur within the warranty period.

- The warranty will only apply if a maintenance contract has been signed, starting from the date of commissioning, and if the maintenance contract has actually been performed.
- The maintenance contract must be made with a specialist, competent company.
- The sole effect of any repair, modification or replacement of an item during the warranty period must be to extend the material's warranty period.
- Maintenance must be carried out in accordance with regulations.
- In addition to annual checks, safety accessories for non-toxic fluids must be requalified (calibrated or replaced) every 12 months, according to the current regulations.
- If a spare part is supplied after the expiry of the warranty period, it shall be guaranteed for a period equal to the initial warranty period and will be subject to the same conditions.
- We recommend for a contract four inspections per year (every three months), before the start of each season, in order to check the operation of the equipment in the various operating modes.

DISPOSAL OF THE EQUIPMENT:

The shutdown of the equipment, the recovery of fluids (oil, refrigerant, water and its mixtures with glycols) must be carried out by qualified personnel in accordance with the recommendations of EN 378-4:2016+A1:2019.

All components of the refrigeration system, such as refrigerants, oil, coolants, filters, dehydrators and insulating materials shall be recovered, reused and/or disposed of properly (see EN 378-4:2016+A1:2019). No material may be disposed of in the environment.

The waste recovery sectors (e.g. eco-organizations,...) are in charge of collecting, cleaning up and recovering WEEE on the whole European market.

WARRANTY

SAFETY:

The safety information contained in this manual is provided as a guide for the safe handling of this installation. LENNOX does not vouch for the completeness of this information and can therefore not accept liability for any possible omissions.

Everyone involved in the product life cycle must perform a risk analysis. This applies to manufacturers, installers, maintainers and end-users. If risks are not eliminated or remain at unacceptable levels of occurrence or severity, they must be communicated to the next party (the customer in general) through the drafting of an installation, use, maintenance guide.

Notwithstanding that the chillers are equipped with extensive safety and protection features, the utmost care and attention is needed when carrying out operations on the machine. Furthermore, ear protection should be worn when working on or in the vicinity of the chillers. Operations on the cooling circuit or electrical equipment should be carried out by authorised personnel.

It is essential to follow non exhaustive recommendations hereunder:

- Never work on a unit that is still energized. Wait 15 minutes before working on the machine after a power outage (discharge of the capacitors).
- Any manipulation (opening or closing) of a shut-off valve must be carried out by a qualified and authorized engineer. These procedures must be carried out with the unit shut-down.
- Never work an electrical component until the general power supply to the unit has been cut. During any maintenance operations on the unit, lock the power supply circuit in the open position ahead of the machine. If the work is interrupted, check the lock before resuming the work.
- **WARNING:** Even if the unit has been switched off, the power circuit remains energized, unless the unit or circuit disconnect switch is open. Refer to the wiring diagram for further details.
- In case of maintenance operations on fans (grills replacement ...) ensure that the power is shut off to avoid automatic restart.
- Before the opening of the refrigerant circuit, check the pressure with manometers or pressure sensors, and purge the circuit in accordance with current environmental directives.
- Never leave a unit stopped with valves closed on the liquid line, refrigerant could be trapped and the pressure would rise.
- All installation parts must be maintained by the personnel in charge, in order to avoid material deterioration and injuries to people. Faults and leaks must be repaired immediately. The authorized technician must have the responsibility to repair the fault immediately. Each time repairs have been carried out to the unit, the operation of the safety devices must be re-checked.
- Follow guidance and recommendations given in safety and machine standards such as EN378, ISO5149, etc. The use of the EN 378-2 standard provides you with the state of the art with regard to the essential safety requirements of the Machine Directives and DESP.
- Do not use oxygen to purge lines or to pressurize a machine for any purpose. Oxygen gas reacts violently with oil, grease, and other common substances.
- Never exceed the specified maximum operating pressures.
- Verify the allowable maximum high- and low-side test pressures by checking the instructions in this manual and the pressures given on the unit name plate.
- Do not use air for leak testing. Use only nitrogen or dry nitrogen.
- Do not unweld or flame cut the refrigerant lines or any refrigerant circuit component until all refrigerant (liquid and vapor) has been removed from roof top. Successive purges with a neutral gas (such as dry nitrogen) are recommended to remove all traces of refrigerant. Refrigerant in contact with an open flame produces toxic gases.
- Do not siphon refrigerant.
- Wearing PPE is mandatory (glasses, cuffs, gloves, masks). Avoid splashing refrigerant on the skin or in the eyes. Wash any spills from the skin with soap and water. If liquid refrigerant enters the eyes, immediately and abundantly flush the eyes with water and consult a doctor.

WARNING

Warning labels

The chiller may be marked with the following warning labels to alert to potential hazards (on or near the potentially hazardous part). The chiller may include the following labels.

High temperatures	Low temperatures	Rotating parts	Sharp parts
Electrical voltage	Flammable	Non-flammable liquefied gas (high pressure)	Flammable liquefied gas (high pressure)
Don't walk on it	Wear of PPE (Personal protective equipment)	Warning inflammable dusty filters	Don't strap
Gravity center	Warning main switch supplied from bottom	EUROVENT certification	
Protection by water filter mandatory	Protection by strainer filter mandatory		
OK to send document	Information to read	Electrical connections can loosen during transport Please check them before start-up	
CMIM marking (Morocco)	CE marking	CA marking (UK)	EAC marking (Russia)

Regularly check that the warning labels are still in the correct positions on the machine and replace them if necessary.

WARNING**PED DIRECTIVE:**

For units covered by the Pressure Equipment Directive (see EU Declaration of Conformity).

**WARNING:**

1. All work on the unit must be performed by competent and qualified personnel. Failure to comply with the following instructions could result in serious injury or accident.
2. **Warning:** High pressure safety switches are safety accessories that keep the system within its permissible operating limits.
3. In case of installation in an earthquake zone or in an area that may be affected by severe natural events such as storms, tornadoes, floods, tidal waves, etc., the installer and/or operator shall refer to the applicable standards and regulations to ensure that the required devices are available, as our units are not designed to operate under such conditions without prior precautions.
4. The pressure increase in case of external fire is not considered as an operating condition (EN 378-2:2016 § 6.2 .2.3). However, the designer may implement means to limit damage in case of fire: Our products, even when equipped with LFL sensors (for products loaded with A2L fluids) are not designed to withstand a fire. This fire risk must be taken into account by the integrator/installer in the risk analysis of the location where our products are installed. The installation site must implement all necessary fire protection measures and comply with applicable regulations. The installation of means as described in EN 378-3+A1:2020 for refrigeration systems in a separate room for refrigeration machines fulfills the requirement for damage limitation. A damage limitation accessory may be present if necessary.
5. In case of exposure to corrosive external atmospheres or corrosive products, the installer and/or operator shall take the necessary precautions to avoid damage to the equipment and shall ensure that the equipment supplied has the necessary and sufficient corrosion protection.
6. To respect a sufficient number of supports for the piping according to their size and weight under operating conditions and to design the piping to avoid a water hammer phenomenon.
7. For factory hermetically sealed refrigeration systems charged with refrigerant, a safety chain test is performed at the end of the test to ensure proper operation of the factory pressure switch. As hydrostatic tests cannot be carried out on all our units for prejudicial reasons, a visual examination, a pressure resistance test at 1.1 x PS and a tightness test are planned. (The whole circuit is checked with a leak detector).
8. If a valve is present, the refrigerant emissions from the safety valves must be directed to the outside, to a place free of ignition sources, fresh air intake and human presence. The valve shall be sized and connected in accordance with EN 13136 +A1: 2018.
9. When carrying out any work, comply with all applicable safety regulations and standards (e.g., EN 378-2:2016), and follow the recommendations on the labels or in the instructions accompanying the equipment. All necessary measures must be taken to prevent access to not competent persons.
10. It is essential that any piping or other components of the refrigeration circuit hazardous to people because of their surface temperature are insulated or identified.
11. Ensure that the installation zone (room or area) of the machine has restricted access and ensure the good condition of the covering.

FLAMMABLE GASES

As standard, the eCOMFORT range is supplied with R32 refrigerant which is a flammable gas classified A2L (slightly flammable).

A2L / A2 / A3 flammable gases are subject to more important safety regulations than gases classified A1. This section summarizes the standard and provides specific Lennox recommendations. This section is based on the standards as well as numerical simulations and tests related to the flammability risk carried out on these products. It provides the recommendations to be considered so that the product is installed, used, maintained and destroyed at the end of its life cycle without putting the actors in the product life cycle at risk.

FLAMMABILITY CLASS	
A1	Non-flammable
A2L	Slightly flammable
A2	Low flammable
A3	Highly flammable

LABELS OF FLAMMABLE GAS UNIT:



The A2L logo on the nameplate indicates that the product contains refrigerant of the slightly flammable category. It is also positioned on schraders where refrigeration components can be connected for maintenance. This label tells you that there is a potential risk of a flammable gas leak and that this should be taken into account in the operational risk analysis.

TRANSPORT OF FLAMMABLE GAS UNIT:



Machines loaded with A2L refrigerant must comply with the ADR rules (Accord for dangerous goods by road). Please plan the route in accordance with this class. In the case of specific air transport requiring machines not charged with refrigerant, please contact your Lennox contact.

UN3358 transports are not allowed in Eurotunnel and tunnels of category D and E.

Containers must be fitted with stickers according to the plan below:

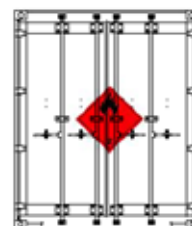
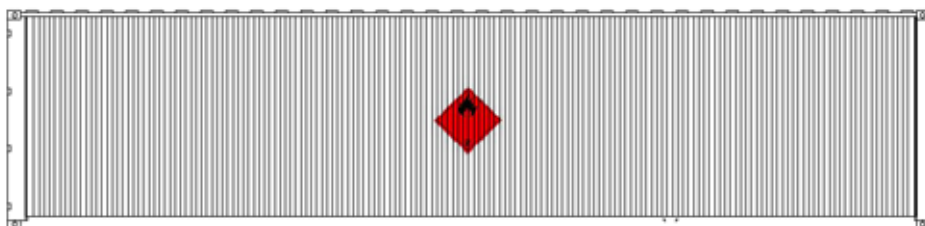

In the transport voucher, note: Refrigerant units.

In case the machine contains more than 12kg of refrigerant, please also note the total amount of refrigerant on the transport voucher.

In the case of maritime transport, the IMDG (International Maritime Dangerous Goods Code) is based on the same rules as the ADR. Some specific local rules may apply (especially in Asia).

FLAMMABLE GASES

RECEPTION CONTROLS FOR A FLAMMABLE GAS UNIT:

Please do not approach the container or truck in the presence of an open flame, an electric power source, a cell phone, or any other heat source whose temperature would exceed 500°C.

Likewise, if the product had to be stored prior to installation, please store it in a place free from potential sources of ignition as described above.

SAFETY:

Persons working on refrigeration systems using flammable fluids must have the necessary skills in accordance with EN 13313:2011 for the safe handling of these flammable fluids.

- Knowledge of the legislation, regulations and standards concerning flammable refrigerants.
- Knowledge of fluids and their handling.

These skills must be supported by appropriate training.

Only equipment designed for use with flammable refrigerants should be used and all work performed on the equipment should be in accordance with local regulations and standards. Of course, all work must be carried out in a professional manner.

To ensure the absence of a secondary ATEX zone, maintainers should:

- Set up a periodic leakage inspection plan to ensure that the product's leakage level is maintained.
- Set up an inspection and maintenance plan to avoid deterioration of the product that could lead to an accidental leak during the life of the equipment.
 - Corrosion: Do not use detergents. Do not use in an atmosphere corrosive to copper and aluminum without protecting the sensitive elements of the exchanger.
 - Freezing of the heat exchanger coil: Check regularly that the coil is not frozen. Check that the defrosting system is working properly and that it is effective.
 - Abnormal vibrations: Check that the pipes are properly maintained.
- If a safety chain is installed, please maintain the detection system and the associated control chain according to standards.

SAFETY AREA:

Our products (Rooftops, Chillers) and quasi-machines (evaporators, air-cooled condensers, ...) are hermetically sealed and carry the CE mark. They are designed to contain slightly flammable A2L refrigerants. As such they are not considered as a source of release as defined by the directive in normal operation. In France, they are exempt from the measures described in the regulation governing the safety of buildings open to the public (ERP).

A formalized periodic inspection of the product's hermeticity will guarantee the preservation of this high level of hermeticity. Nevertheless, in abnormal operating conditions, leaks may occur (poor maintenance, maintenance with opening of the refrigeration circuit). For these cases, prior to placing these products on the market, we carried out studies in accordance with standards. Thus the unit installed according to our recommendations and well maintained does not generate an ATEX zone.

Please maintain the detection system and the associated control chain according to standards. In case of maintenance we recommend that the operators be equipped with an explosimeter, switch off the power supply to the unit and do not approach any potential source of ignition without first checking the absence of a potentially flammable area due to an undetected leak.

The end user should update the DUER (Document Unique d'Evaluation des Risques) indicating the presence on his site of products charged with R32 fluid, and train his personnel on the good practices to be adopted for a safe use.

INSTALLATION ON A FLAMMABLE GAS UNIT:

It is forbidden to store and install the machine in an ATEX area.

In the immediate area of the unit (proximity distance \leq to 2m):

- The presence, even temporary, of ignition sources is prohibited (electrical or heat sources),
- It is forbidden to install fresh air vents in the building or in extracts

For ducting / ducted units, ensure that no sources of ignition as defined in the standards (e.g. electrical and heat) are installed in or near the ducts.

FLAMMABLE GASES

POWERING UP A UNIT CONTAINING FLAMMABLE GAS:

Before switching on the power supply, please carry out a refrigerant leak detection using an appropriate device to ensure that there is no refrigerant around the machine. . Please perform a refrigerant detection with a suitable and calibrated detector to ensure that there is no gas around the unit.

ELECTRIC WIRING ON A UNIT CONTAINING FLAMMABLE GAS:

When a cable passes through a wall, be sure to use a cable gland to ensure that the cable is sealed and insulated. This insulation prevents any electric arcs that could ignite the refrigerant if leaked.

INTERVENTION ON A UNIT CONTAINING FLAMMABLE GAS:

Before any intervention on a machine with A2L / A2 / A3 flammable fluid, please carry out a refrigerant leak detection using an appropriate device to ensure that there is no refrigerant around the machine.

When working on a machine with flammable fluid A2L / A2 / A3, do not cause sources of flammability in the area near the unit (see above). For example: do not smoke, make phone calls, do not use walkie-talkies.

CORRECTIVE MAINTENANCE ON R32 GAS UNIT:

The following precautions, specific to this gas, must be taken when using the R32 refrigerant;

- The vacuum pump must be fitted with a non-return valve or a solenoid valve and comply with R32 (A2L).
- The pressure control, draining and filling operations of the pressurized system must be carried out using the fittings specified for this purpose and the appropriate equipment.
- Use only pipe cutters and no torches to open the pipes.
- The load must be applied in the liquid phase.
- Always use a scale to charge the refrigerant.
- Use the leak detector suitable for R32 refrigerant.
- Do not use mineral oil, only synthetic oil for boring, expanding or making connections.
- Keep the pipes closed before using them and pay close attention to any traces of humidity and dirt (dust, filings, burrs, etc.).
- Brazing must always be carried out in a nitrogen atmosphere.
- The drill bits must always be sharp.
- The refrigerant bottle must contain at least 2% of the total amount.
- The brazing operation must be performed by a professional.

WARNING:

Care must be taken to remove refrigerant from the system before cutting or unbrazing any piping with a tool suitable for use with A2L fluids.

We recommend the following protocol before any piping work:

- To avoid any risk of explosion due to the spraying of refrigerant liquid and oil, the circuit must be drained and display a relative pressure of zero during the disassembling or debrazing of parts of the refrigerant circuit.
- Vacuum with A2L compatible equipment and recharge with dry nitrogen to allow the fluid dissolved in the oil to degas.
- Repeat these operations twice.
- Once the circuit has been drained, there is a residual risk of pressure build-up by degassing the oil or due to the heat from the exchangers. To keep the pressure at zero, the pipe connection must be bled from the low pressure side.

Vacuum procedure:

- Connect the vacuum pump to the HP line and to the BP line.
- Draw vacuum (P = 1Pa). Break the vacuum with dry nitrogen. Draw vacuum again (P = 1Pa), the residual moisture content must be less than 50ppm.
- Perform a vacuum test (15 minutes at maximum 70Pa).

The compressors must be switched off during the vacuum test.

DATA PAGE FOR UNIT COMMISSIONING

Unit:		Serial no.:	
Control panel identification code:			
Installation address:			
Installer:		Installer tel.:	
Installer address:			
Date of commissioning:			
Checks:			
Supply voltage:		Rated voltage of the unit:	

	YES	NO
Unit on rubber antivibration mounts		
General power supply connection		
Control panel connection (option)		
Compressor oil level indicator		
Hydraulic connection		
Purged of the installation		

DATA INPUT		COOLING CYCLE	HEATING CYCLE
Air Input Temperature, Coil	°C		
Water Output Temperature	°C		
Water Input Temperature	°C		
High Pressure			
Low Pressure			

ELECTRIC POWER CONSUMPTION		COOLING CYCLE	HEATING CYCLE
Compressor 1	A		
Fan 1	A		
Compressor 2	A		
Fan	A		
Compressor 3	A		
Fan 3	A		
Compressor 4	A		
Fan 4	A		

Options Installed:	
Comments:	

1.- GENERAL CHARACTERISTICS

1.1.- TECHNICAL DATA

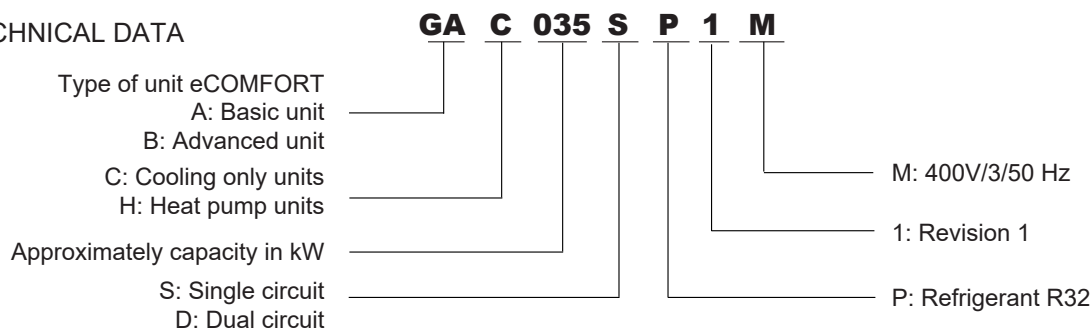

OPTIONS	
LNCJ	Low noise : Accoustic compressor jacket
SFAC	Fixed speed standard AC fans <i>(Only available for basic units)</i>
HIFP	Variable air flow control with high pressure EC fans
ACTR	LenGuard anti-corrosion condenser coil treatment
CPGR	Coils protection: metallic grille
LLWT	Low leaving water temperature down to -12°C
PHRF	Domestic hot water supply: desuperheater
RLKD	Refrigerant leak detection
SPLP	Hydraulic module with low-pressure single pump <i>(Only available for basic units)</i>
DPLP	Hydraulic module with low-pressure twin pump <i>(Only available for basic units)</i>
SPEL	Hydraulic module with eDrive low-pressure single pump
DPEL	Hydraulic module with eDrive low-pressure twin pump
SPHP	Hydraulic module with high-pressure single pump <i>(Only available for basic units)</i>
DPHP	Hydraulic module with high-pressure twin pump <i>(Only available for basic units)</i>
SPEH	Hydraulic module with eDrive high-pressure single pump
DPEH	Hydraulic module with eDrive high-pressure twin pump
BYVC	Bypass Valve for delta P control with eDrive pump (supplied loose)
WTNG	Water tank
WTHS	Water tank electrical heater Standard
WTHH	Water tank electrical heater High
WFIF	Water filter (supplied loose)
KGRL	Flange connection (supplied loose)
ECLO	LonWorks® interface FTT10
BNET	BACnet® interface MSTP
MBUS	ModBus interface RS485
MBIP	ModBus and BACnet® interface TCP/IP
DM60	Remote advanced display (supplied loose)
DS60	Service display (supplied loose)
DCBO	Remote control: customer drive contact input/output
CETH	Lennox Cloud connectivity Ethernet communication
CGSM	Lennox Cloud connectivity GSM communication
APEP	Antifreeze protection on exchangers and pipings down to -20°C
APPP	Antifreeze protection on exchangers, pump(s), piping down to -20°C
APPW	Antifreeze protection on exchangers, pump(s), piping and water tank down to -20°C
ELME	Electric energy meter
PHCT	Phase reversal protection
SOFT	Soft starter
EBFM1	Electrical box upgrade ventilation : 1 fan
EBFM2	Electrical box upgrade ventilation : 2 fans
ALWA	Aluminum wires adaptor (supplied loose)
POWF	Power factor correction
AVUB	Anti-vibration mounts rubber type (supplied loose)
SLCR	Wooden crate for long distance

NOTE: When it is possible options supplied loose should be included in a carton box inside the unit.

1.- GENERAL CHARACTERISTICS

1.1.- TECHNICAL DATA

Basic unit: It uses a fixed speed compressor and as options it can use EC or AC fans and a water pump with or without variable speed.

BASIC UNITS - COOLING ONLY

GAC MODELS		035S	040S	045S	050S	055S	060S	065S	070S	080S	095S
Cooling capacity (*)	Kw	38,4	41,6	47,5	51,8	55,0	63,6	64,3	70,0	86,3	95,8
Number of compressors		2 / Scroll									
Hydraulic connections		1 1/2"				2"					2 1/2"
Nominal water rate	m ³ /h	6,61	7,15	8,17	8,90	9,47	10,94	11,05	12,03	14,84	16,48
Net weight	Kg	325	339	350	379	385	405	565	559	605	679

GAC MODELS		110S	115S	125S	140S	110D	125D	140D	160D	185D	210D
Cooling capacity (*)	Kw	108,3	119,3	128,8	156,3	111,4	127,5	142,3	167,8	187,2	210,5
Number of compressors		2 / Scroll		3 / Scroll		2+2 / Scroll					
Hydraulic connections		2 1/2"							3"		
Nominal water rate	m ³ /h	18,63	20,53	22,15	26,89	19,16	21,93	24,48	28,86	32,19	36,20
Net weight	Kg	701	730	846	932	893	932	911	1216	1340	1340

BASIC UNITS - HEAT PUMP

GAH MODELS		035S	040S	045S	050S	055S	060S	065S	070S	080S	095S
Cooling capacity (*)	Kw	37,7	41,2	46,9	50,5	56,1	63,2	64,3	69,6	84,7	94,1
Heating capacity (**)	Kw	39,1	42,1	48,4	52,2	56,6	64,3	64,9	70,4	84,9	94,8
Number of compressors		2 / Scroll									
Hydraulic connections		1 1/2"				2"					2 1/2"
Nominal water rate	m ³ /h	6,49	7,09	8,07	8,69	9,65	10,87	11,06	11,98	14,57	16,19
Net weight	Kg	350	369	385	416	424	448	614	608	649	742

GAH MODELS		110S	115S	125S	140S	110D	125D	140D	160D	185D	210D
Cooling capacity (*)	Kw	105,3	118,0	126,4	152,0	108,6	125,3	140,3	166,1	187,3	209,1
Heating capacity (**)	Kw	106,7	117,5	126,1	154,5	114,1	129,3	142,5	170,7	190,3	216,1
Number of compressors		2 / Scroll		3 / Scroll		2+2 / Scroll					
Hydraulic connections		2 1/2"							3"		
Nominal water rate	m ³ /h	18,12	20,29	21,74	26,14	18,68	21,55	24,13	28,56	32,21	35,97
Net weight	Kg	771	793	918	1006	975	1017	998	1388	1463	1463

(*) Cooling capacity: Outside temperature: 35°C / Inlet / Outlet water temperature: 12 / 7°C.

(**) Heating capacity: Outside temperature: 7°C DB / 6°C WB / Inlet / Outlet water temperature: 40 / 45°C.



WARNING:
To know the R32 refrigerant charge, see the unit rating plate.

1.- GENERAL CHARACTERISTICS

1.1.- TECHNICAL DATA

Advanced unit: It uses a variable speed compressor and an EC fan and as an option it can use a variable speed water pump.

ADVANCED UNITS - COOLING ONLY

GBC MODELS		040S	060S	070S	080S	110S	120S
Nominal cooling capacity (*)	Kw	34,5	51,3	61,5	77,4	94,6	117,0
Maximum cooling capacity (*) (***)	Kw	43,7	65,1	71,2	87,7	108,3	132,1
Minimum cooling capacity (*) (***)	Kw	18,9	28,6	19,1	19,7	29,9	30,0
Number of compressors	2 / Scroll						
Hydraulic connections	1 1/2"		2"			2 1/2"	
Nominal water rate	m ³ /h	5,94	8,83	10,58	13,32	16,26	20,12
Net weight	Kg	332	367	547	640	682	721

GBC MODELS		125D	140D	160D	185D	210D
Nominal cooling capacity (*)	Kw	124,8	146,7	159,5	170,0	196,6
Maximum cooling capacity (*) (***)	Kw	133,8	154,9	169,0	179,5	210,5
Minimum cooling capacity (*) (***)	Kw	20,8	21,1	20,9	20,5	30,7
Number of compressors	2+2 / Scroll					
Hydraulic connections	2 1/2"			3"		
Nominal water rate	m ³ /h	21,47	25,24	27,44	29,23	33,82
Net weight	Kg	894	949	1201	1283	1283

ADVANCED UNITS - HEAT PUMP

GBH MODELS		040S	060S	070S	080S	110S	120S
Nominal cooling capacity (*)	Kw	33,6	50,0	60,6	71,9	87,6	109,2
Maximum cooling capacity (*) (***)	Kw	42,0	62,6	69,7	81,0	99,1	121,5
Minimum cooling capacity (*) (***)	Kw	18,7	27,9	18,0	17,5	27,0	26,8
Nominal heating capacity (**)	Kw	34,4	51,1	64,0	78,4	94,0	116,5
Maximum heating capacity (**) (***)	Kw	45,6	66,9	75,2	89,5	108,2	130,6
Minimum heating capacity (**) (***)	Kw	19,3	29,0	19,9	20,0	31,2	31,2
Number of compressors	2 / Scroll						
Hydraulic connections	1 1/2"		2"			2 1/2"	
Nominal water rate	m ³ /h	5,78	8,61	10,43	12,37	15,07	18,78
Net weight	Kg	351	401	609	705	746	789

GBH MODELS		125D	140D	160D	185D	210D
Nominal cooling capacity (*)	Kw	123,5	144,1	158,1	169,9	196,0
Maximum cooling capacity (*) (***)	Kw	131,2	151,5	166,1	179,3	209,1
Minimum cooling capacity (*) (***)	Kw	21,3	21,4	21,3	20,9	31,5
Nominal heating capacity (**)	Kw	126,8	146,9	161,1	171,3	200,6
Maximum heating capacity (**) (***)	Kw	137,8	156,4	172,1	182,3	216,8
Minimum heating capacity (**) (***)	Kw	20,9	21,4	21,1	20,6	31,2
Number of compressors	2+2 / Scroll					
Hydraulic connections	2 1/2"			3"		
Nominal water rate	m ³ /h	21,25	24,78	27,20	29,23	33,71
Net weight	Kg	1001	1065	1360	1427	1427

(*) Cooling capacity: Outside temperature: 35°C / Inlet / Outlet water temperature: 12 / 7°C.

(**) Heating capacity: Outside temperature: 7°C DB / 6°C WB / Inlet / Outlet water temperature: 40 / 45°C.

(***) Maximum / minimum cooling / heating capacity depending on the minimum / maximum speed of the compressor.



WARNING:
To know the R32 refrigerant charge, see the unit rating plate.

1.- GENERAL CHARACTERISTICS

1.1.- TECHNICAL DATA

HYDRAULIC CIRCUIT (HY) / (HN)

GAC / GAH		035S	040S	045S	050S	055S	060S	065S	070S	080S	095S
GBC / GBH		040S			060S			070S - 080S			
Low pressure pump	Type	Stainless steel threaded centrifugal pumps									
High pressure pump											
Expansion vessel	Type	Fixed membrane expansion vessel									
	Max. pressure (bar)	4									
	Capacity (dm ³)	18					35				
Buffer tank (***)	Type	Isolated steel tank									
	Safety valve set (bar)	3									
	Volume (dm ³)	100					N/A		173		

GAC / GAH		110S	115S	125S	140S	110D	125D	140D	160D	185D	210D
GBC / GBH		110S - 120S		125D - 140D				160D		185D	210D
Low pressure pump	Type	Stainless steel threaded centrifugal pumps									
High pressure pump											
Expansion vessel	Type	Fixed membrane expansion vessel									
	Max. pressure (bar)	4									
	Capacity (dm ³)	35					50				
Buffer tank (***)	Type	Isolated steel tank									
	Safety valve set (bar)	3									
	Volume (dm ³)	173		250				325			

(***) Only in units with Hydronic module

FAN DATA

**GAC 035S - 040S - 045S
GBC 040S**

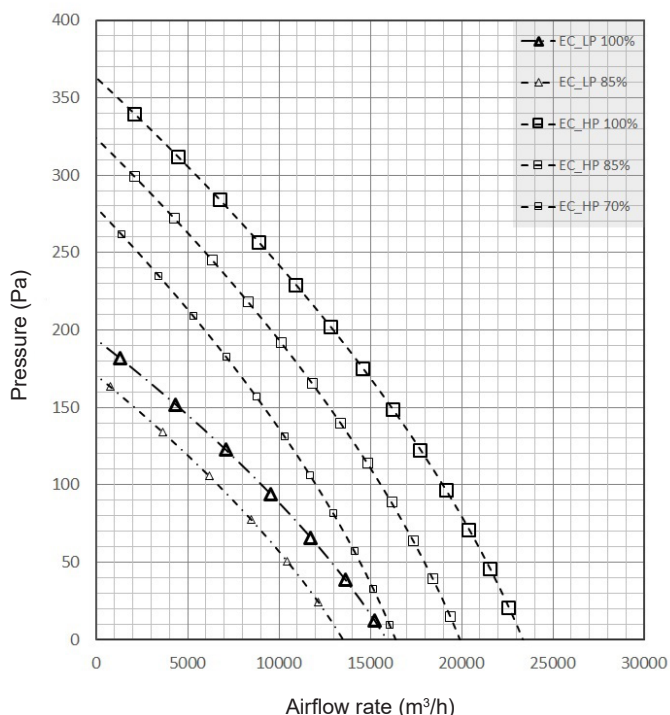

**GAH 035S - 040S - 045S
GBH 040S**

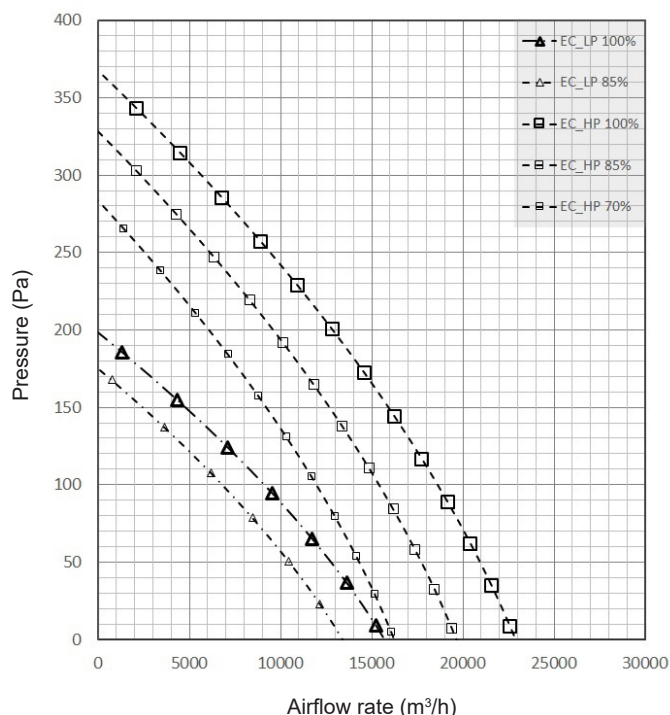

1.- GENERAL CHARACTERISTICS

1.1.- TECHNICAL DATA

FAN DATA

GAC 050S - 055S

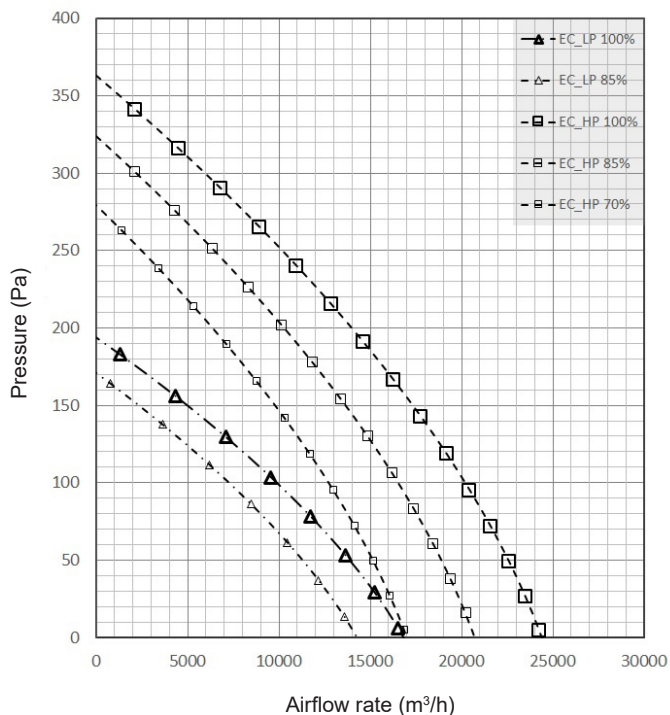

GAH 050S

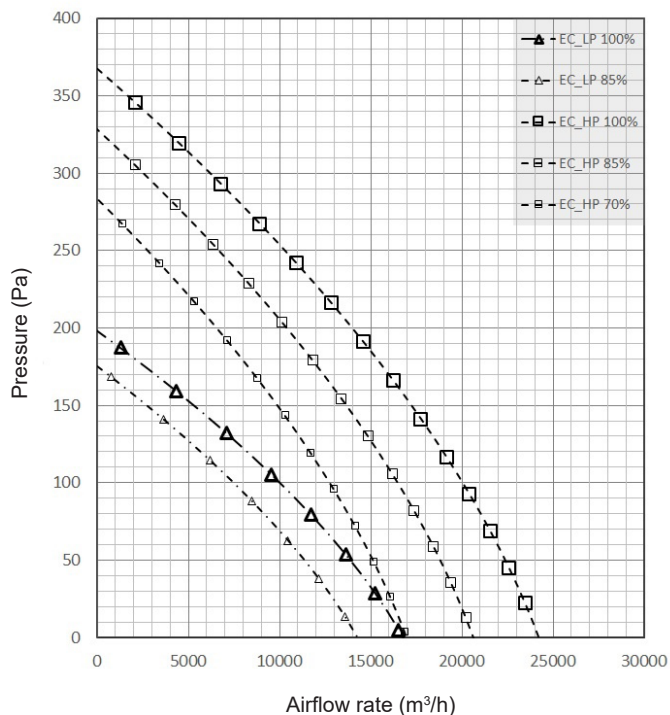

**GAC 060S
GBC 060S**

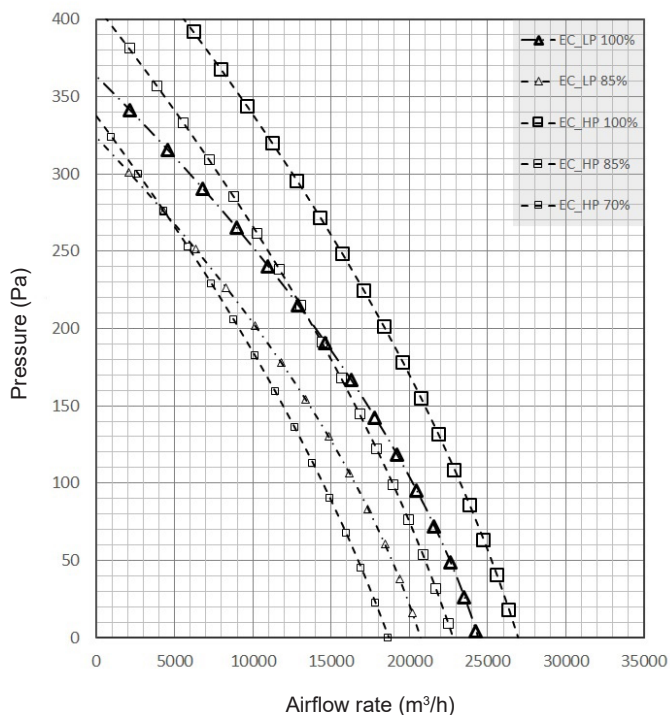

**GAH 055S - 060S
GBH 060S**

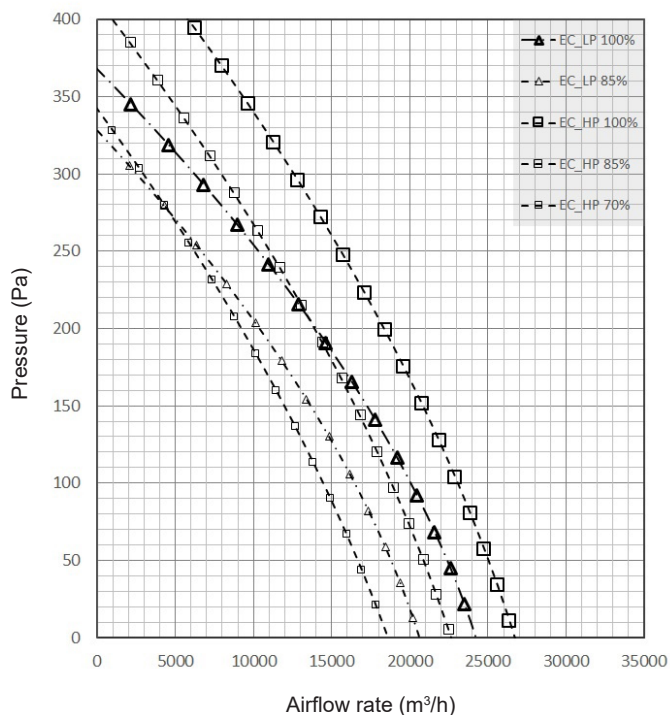

1.- GENERAL CHARACTERISTICS

1.1.- TECHNICAL DATA

FAN DATA

**GAC 065S - 070S - 080S
GBC 070S**

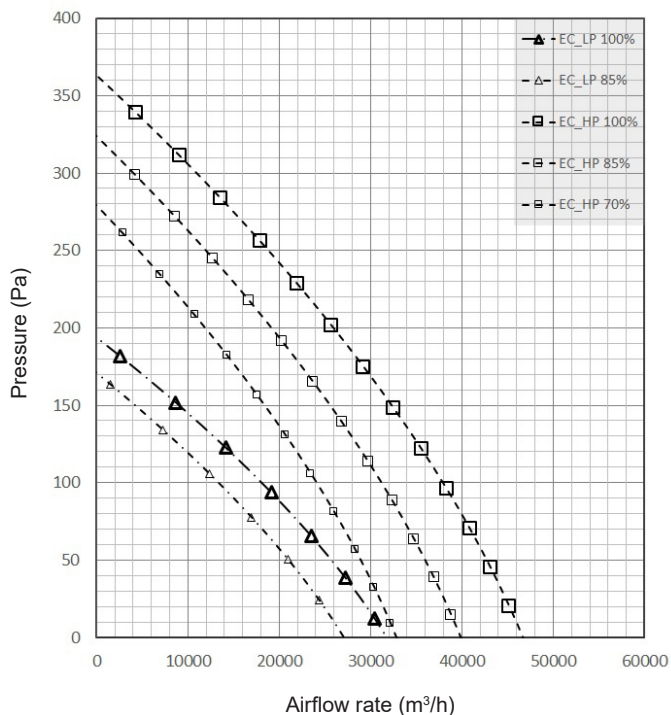

GBC 080S

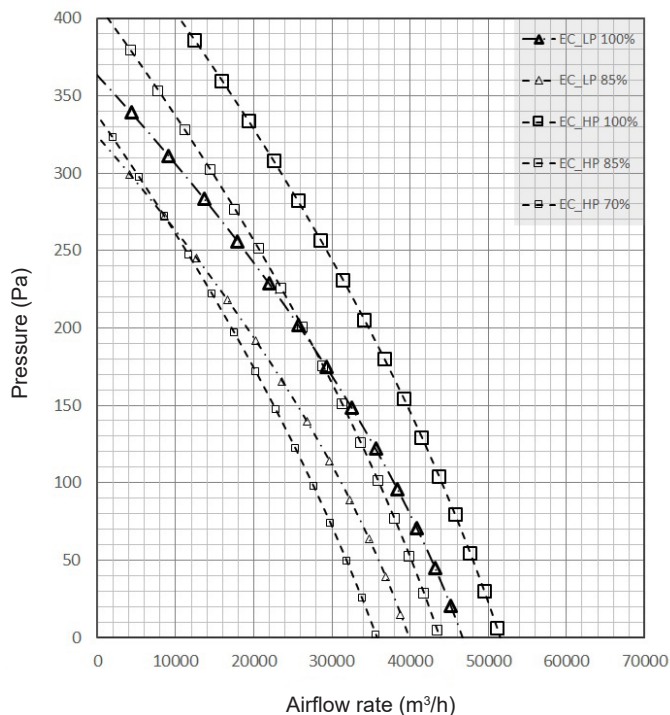

**GAH 065S - 070S - 080S
GBH 070S**

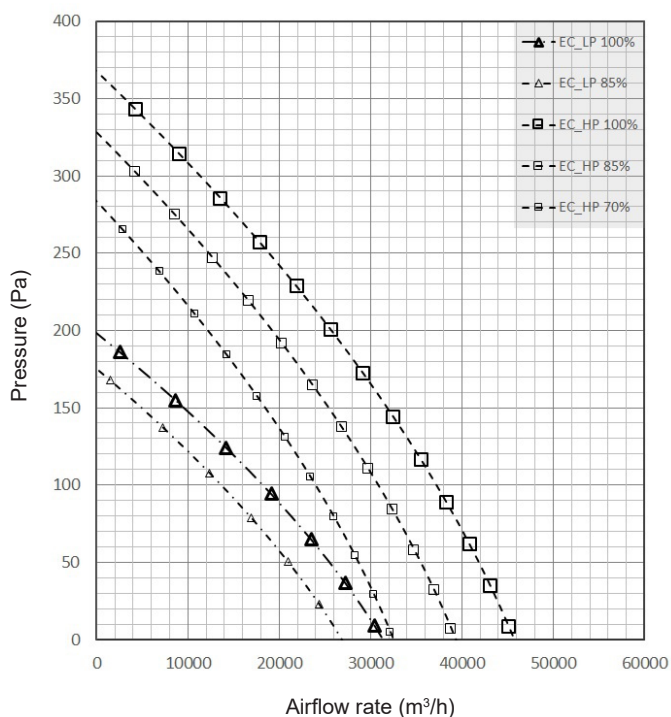

GBH 080S

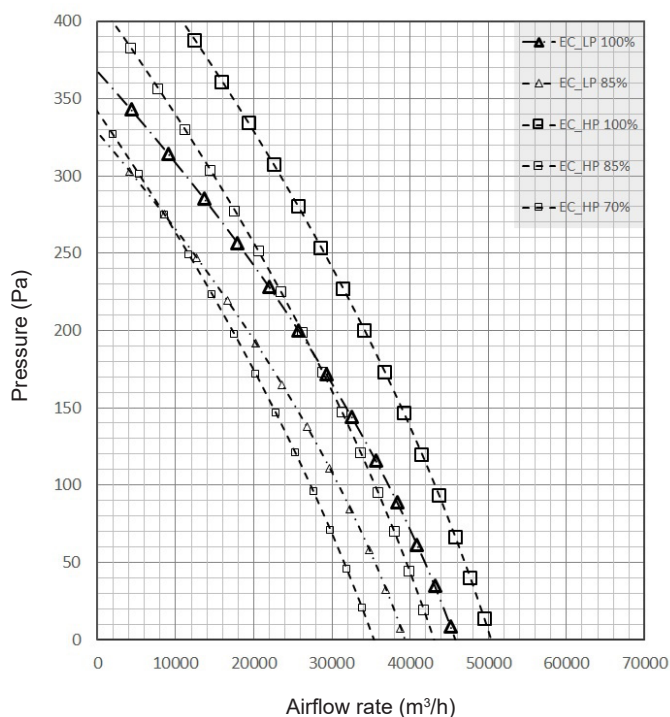

1.- GENERAL CHARACTERISTICS

1.1.- TECHNICAL DATA

FAN DATA

**GAC 095S - 110S - 110D
GBC 110S**

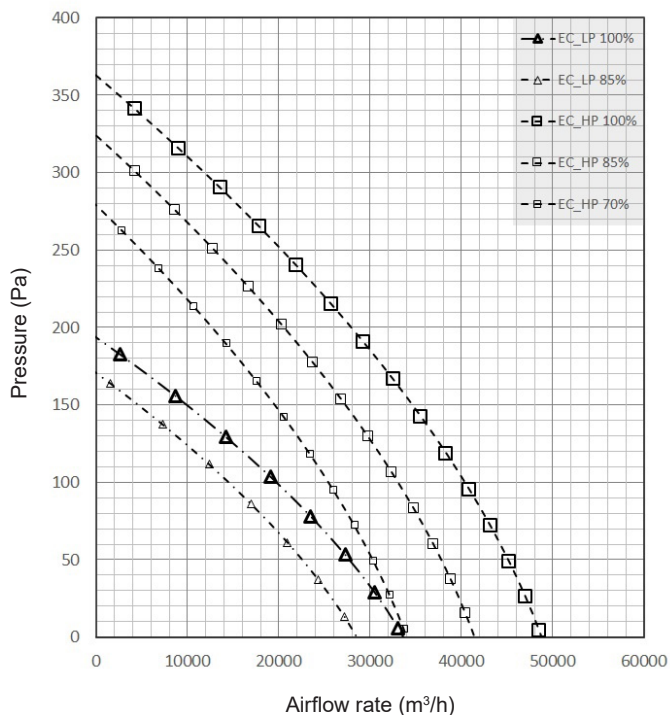

**GAH 095S - 110S - 110D
GBH 110S**

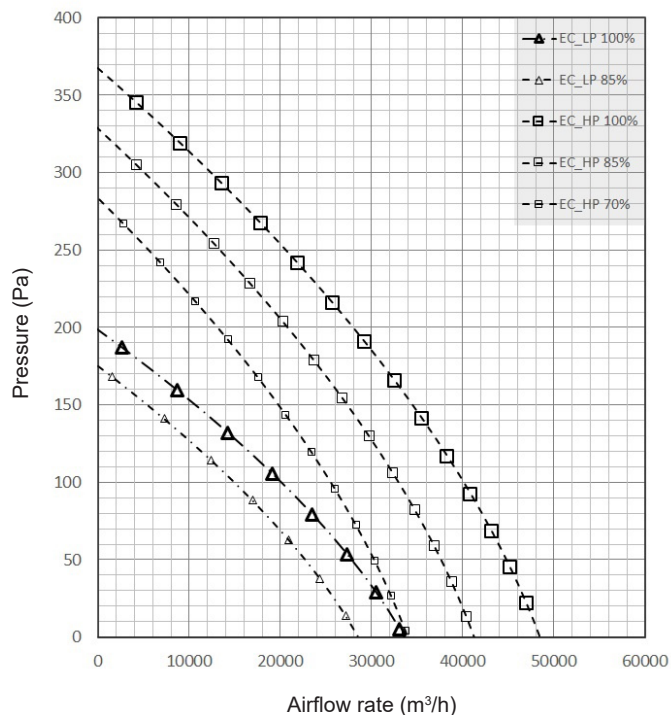

**GAC 115S - 125S - 125D
GBC 120S - 125D**

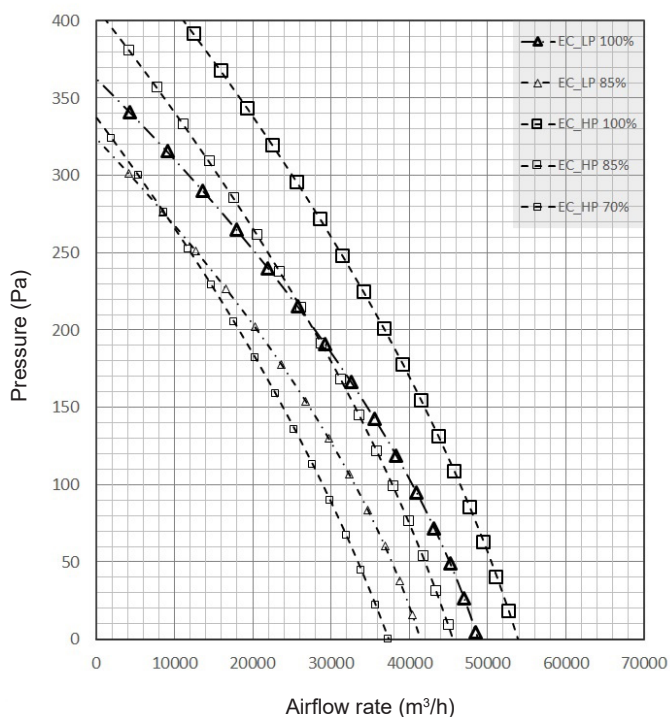

**GAH 115S - 125S - 125D
GBH 120S - 125D**

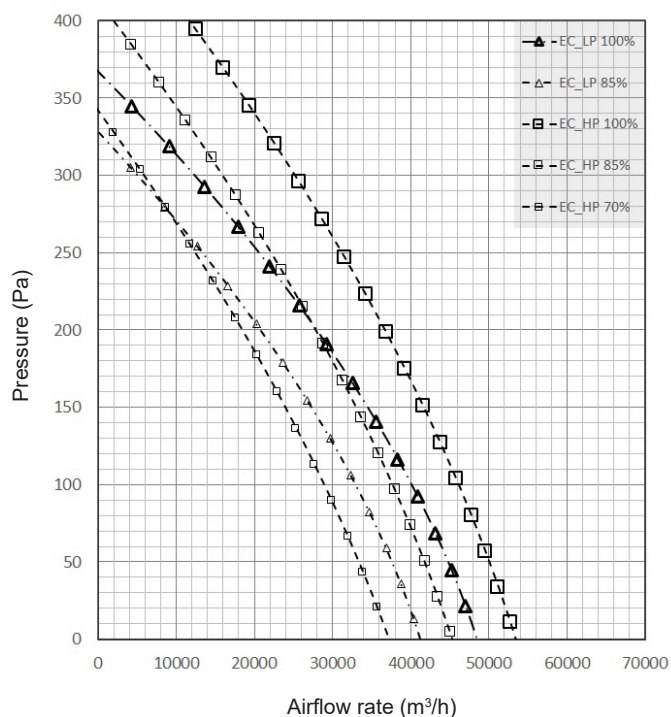

1.- GENERAL CHARACTERISTICS

1.1.- TECHNICAL DATA

FAN DATA

**GAC 140S - 140D
GBC 140D**

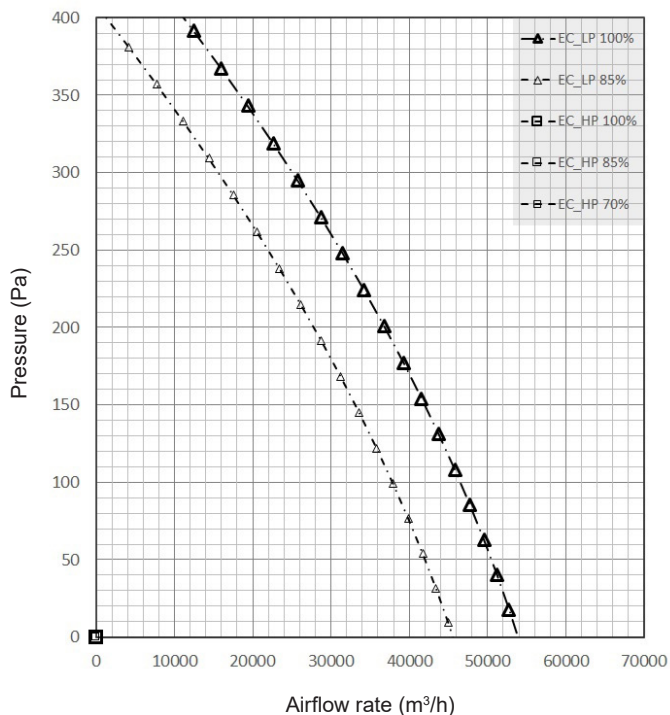

**GAH 140S - 140D
GBH 140D**

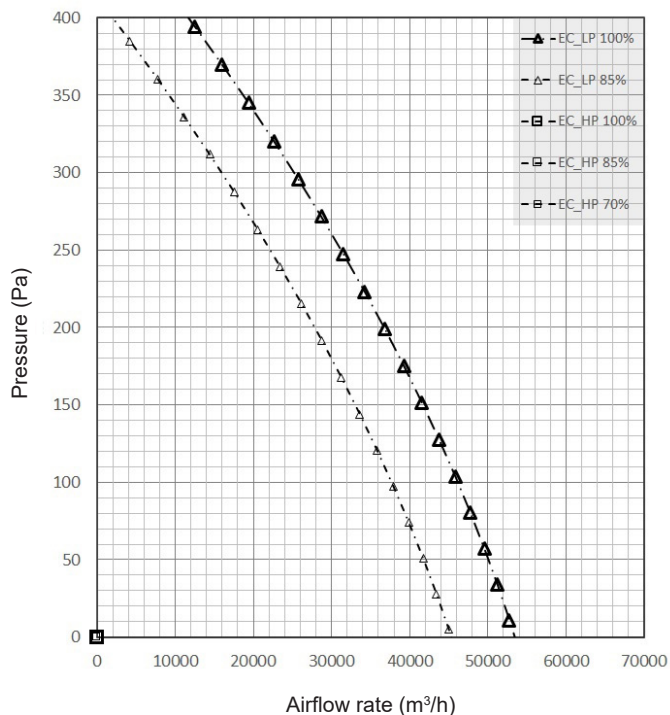

**GAC 160D
GBC 160D**

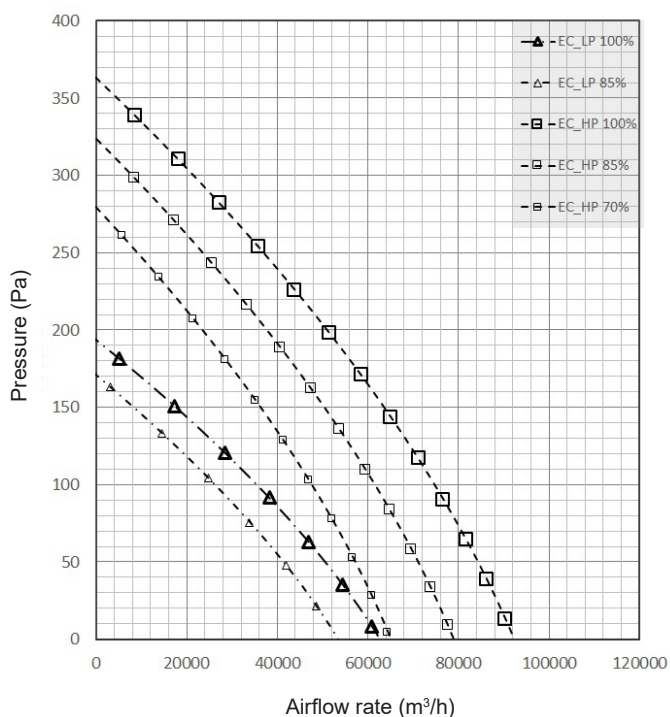

**GAH 160D
GBH 160D**

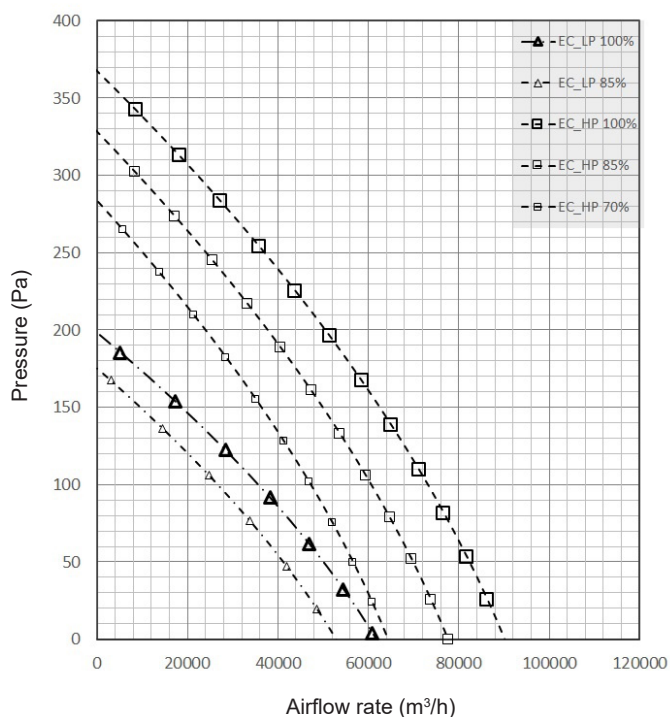

1.- GENERAL CHARACTERISTICS

1.1.- TECHNICAL DATA

FAN DATA

**GAC 185D - 210D
GBC 185D - 210D**

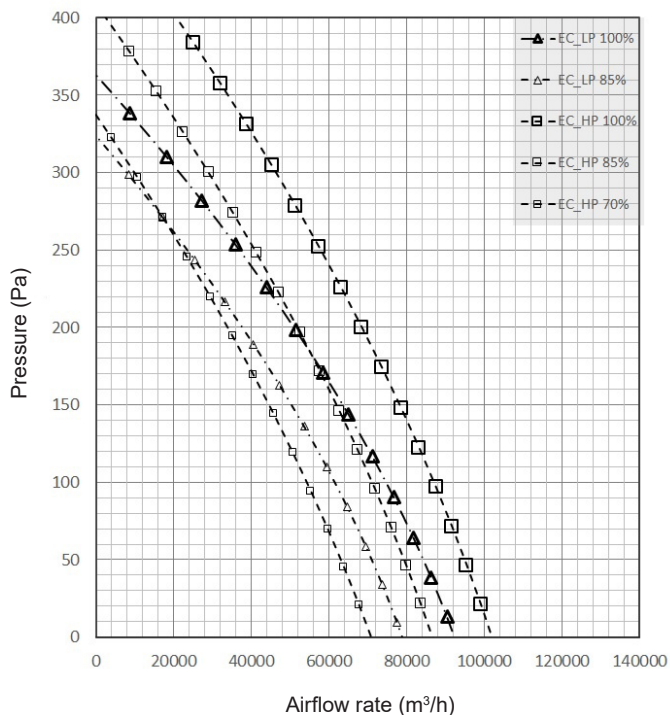

**GAH 185D - 210D
GBH 185D - 210D**

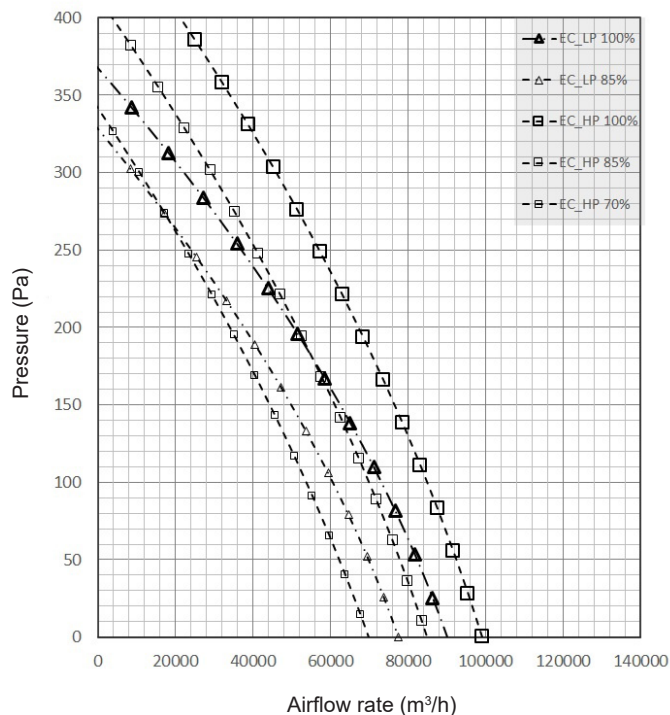

1.2.- COMPONENTS

The eComfort R32 system comprises a water cooler or air/water pump combined with a series of hydraulic accessories.



WARNING:
Check the inlet and outlet position of the water piping on the dimension drawings.
See indications on unit.

STANDARD UNIT

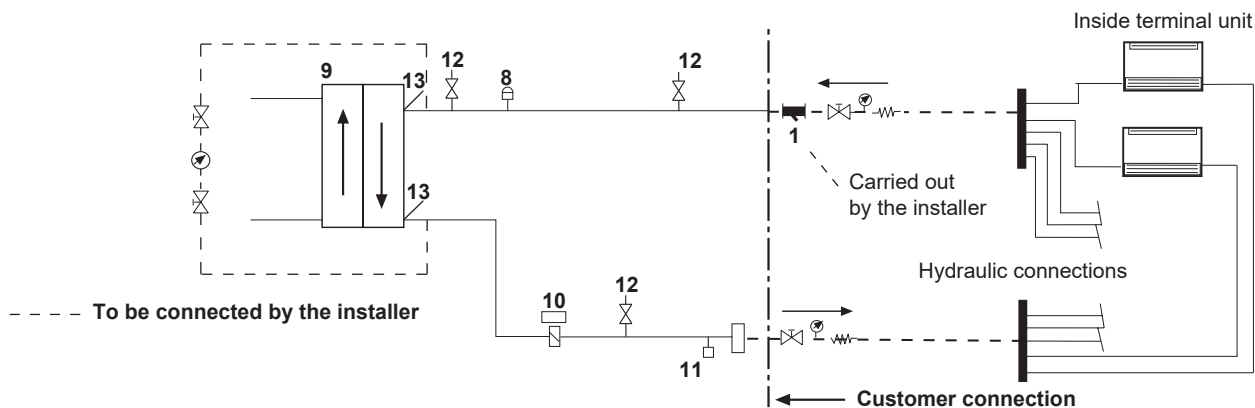

1.- GENERAL CHARACTERISTICS

1.2.- COMPONENTS

UNIT WITH WATER PUMP OPTION

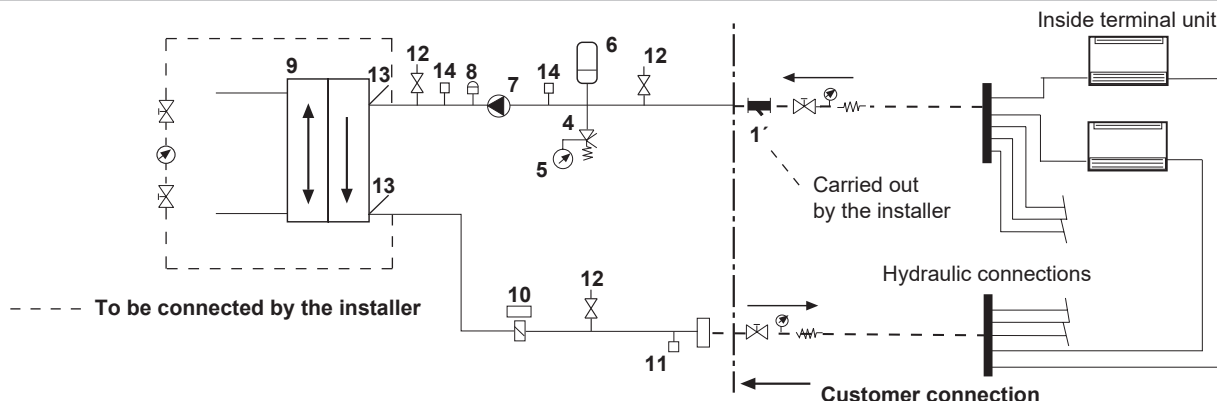

UNIT WITH WATER TANK OPTION

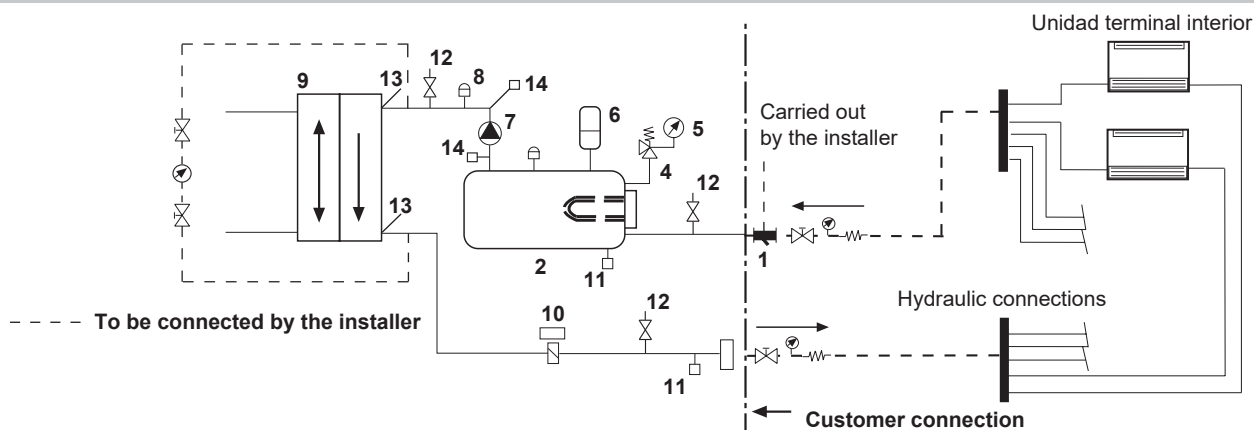

COMPONENTS:

STANDARD VERSION (STD):	UNIT WITH WATER PUMP OPTION (HY):	UNIT WITH WATER TANK OPTION (HN):
8, 9, 10, 11, 12, 13	4, 5, 6, 7, 8, 9, 10, 11, 12, 13, 14	2, 3, 4, 5, 6, 7, 8, 9, 10, 11, 12, 13, 14

1	Water filter (additional option, supplied loose)	6	Expansion vessel	11	Drain valve
2	Water tank	7	Water pump	12	Pressure tap
3	Water tank heater	8	Air purge valve	13	Water temperature sensor
4	Safety valve	9	Plate exchanger	14	Pressure transducer (when variable water flow option is selected)
5	Pressure gauge	10	Flow switch		

The use of a water filter in the water circuit upstream of the heat exchanger is mandatory. These filters must remove all particles with a diameter greater than 1 mm, and must be positioned within 1 meter of the inlet of the exchanger. They may be supplied as an option by the manufacturer.

1.- GENERAL CHARACTERISTICS

1.3.- OPERATING LIMITS

BASIC UNITS + ADVANCED UNITS: COOLING ONLY

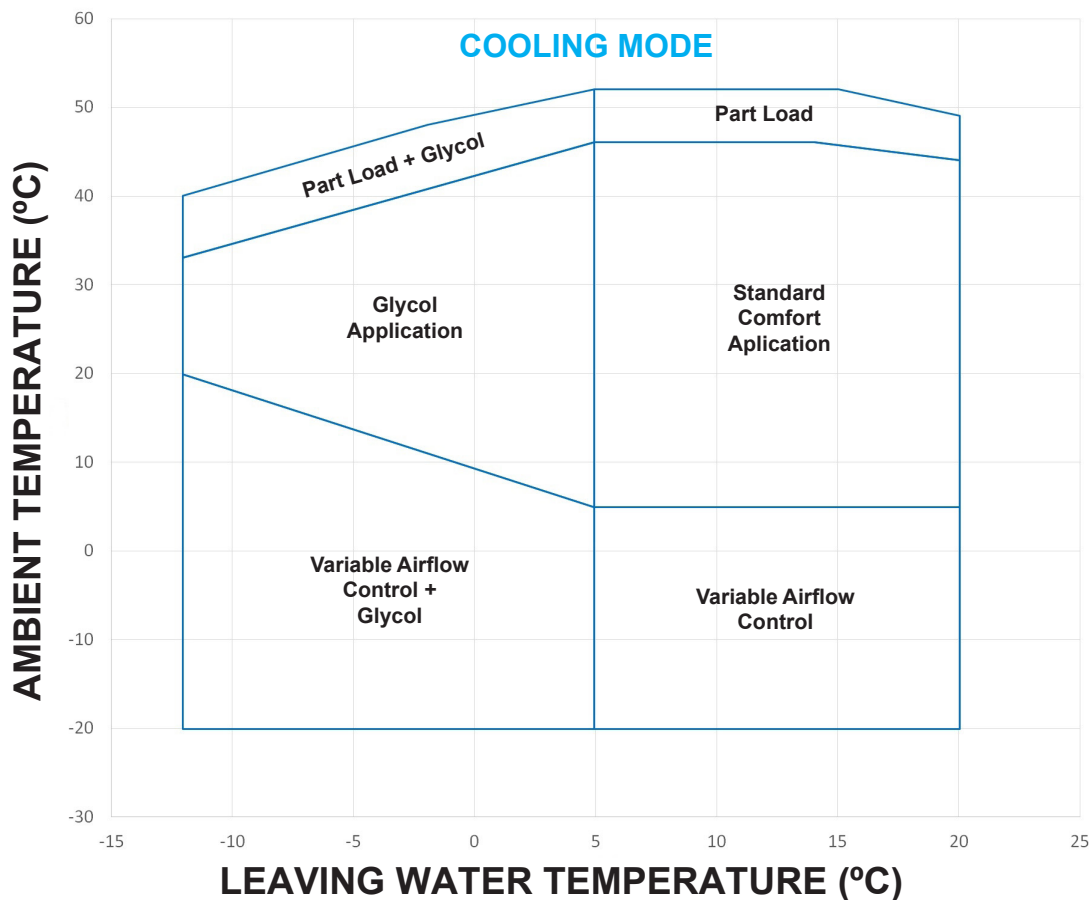

ADVANCED UNITS - SINGLE CIRCUIT: HEAT PUMP

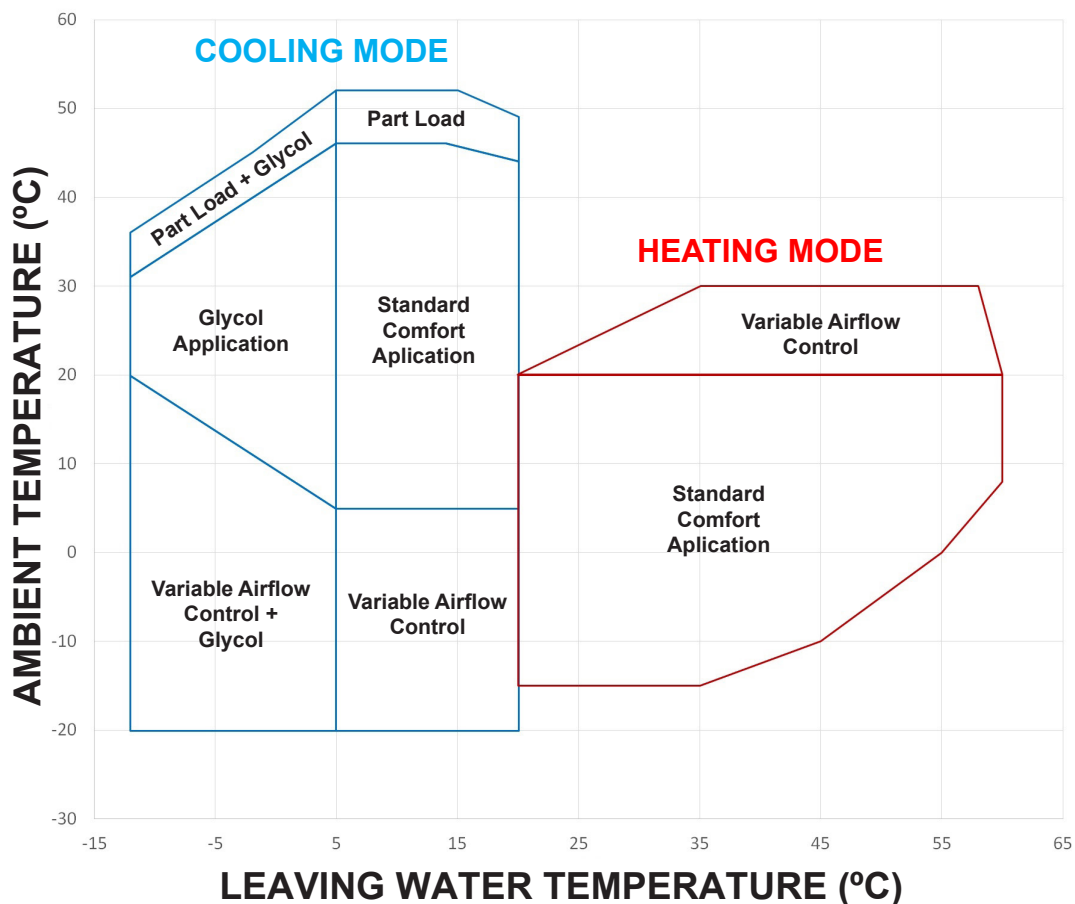

1.- GENERAL CHARACTERISTICS

1.3.- OPERATING LIMITS

BASIC UNITS + ADVANCED UNITS - DUAL CIRCUIT: HEAT PUMP

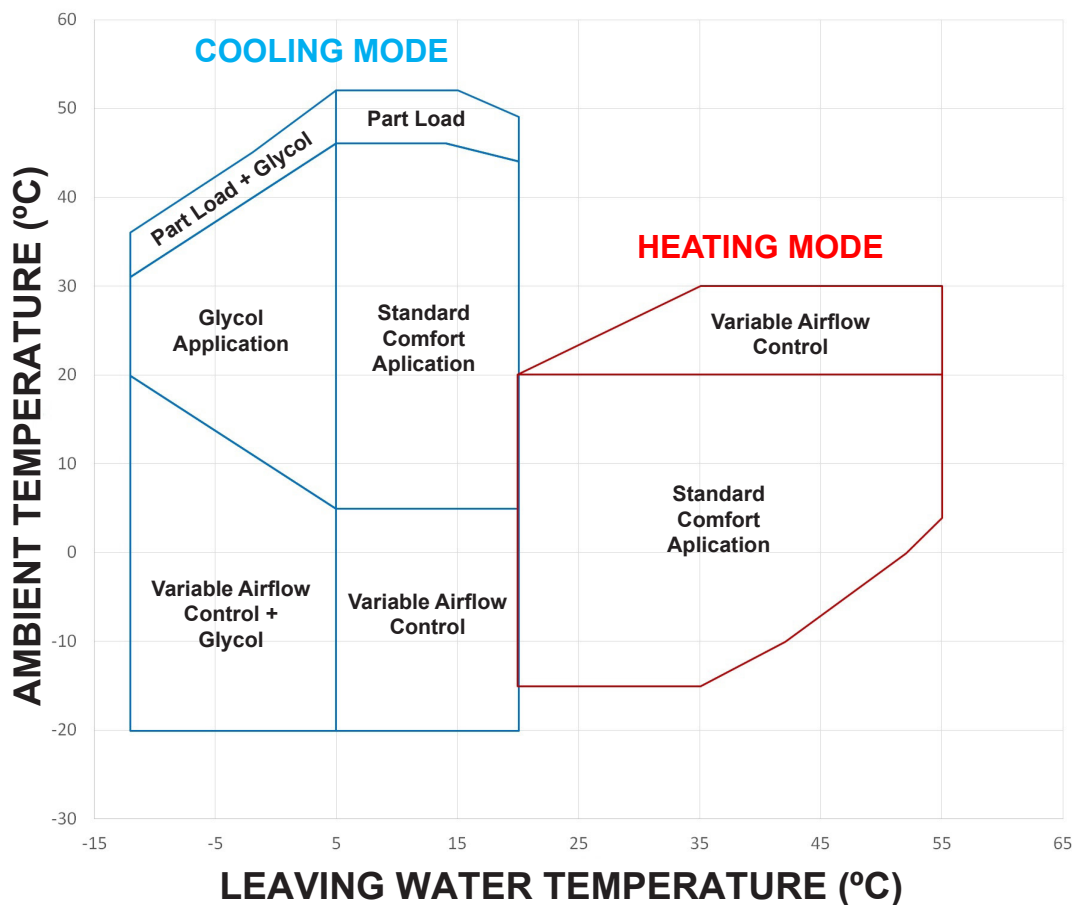

Operating ranges are guidelines only. Verify the operating range with our selection tool.
Water type heat exchanger: ΔT 5K.

UNITS WITH LOW WATER TEMPERATURE KIT (OPTION)

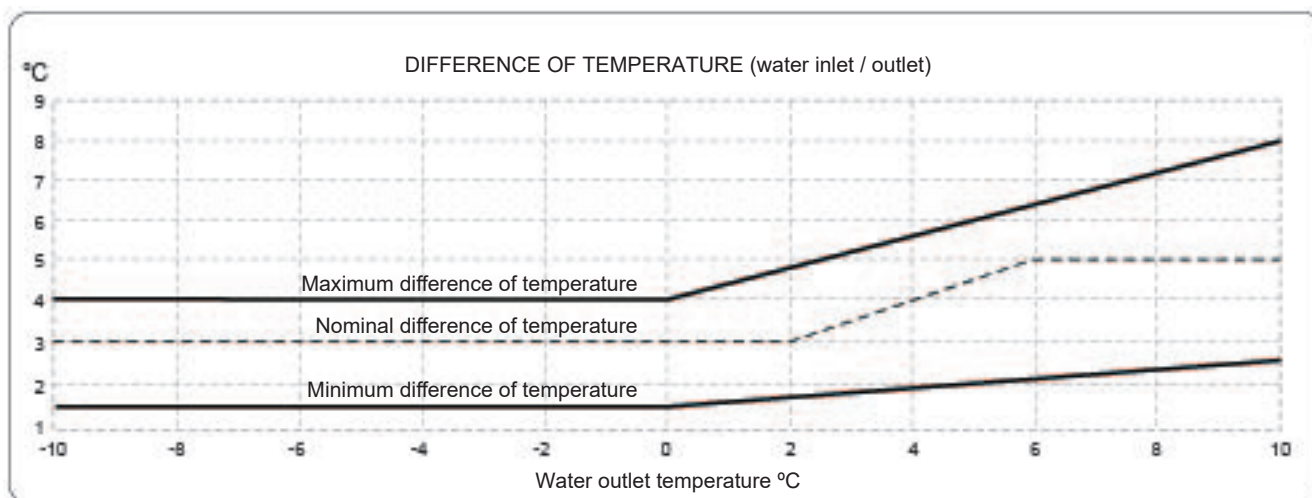

1.- GENERAL CHARACTERISTICS

1.4.- HYDRAULIC SYSTEM DATA

WATER FLOW AND AVAILABLE STATIC PRESSURE OF WATER PUMP

GAC/H 035S

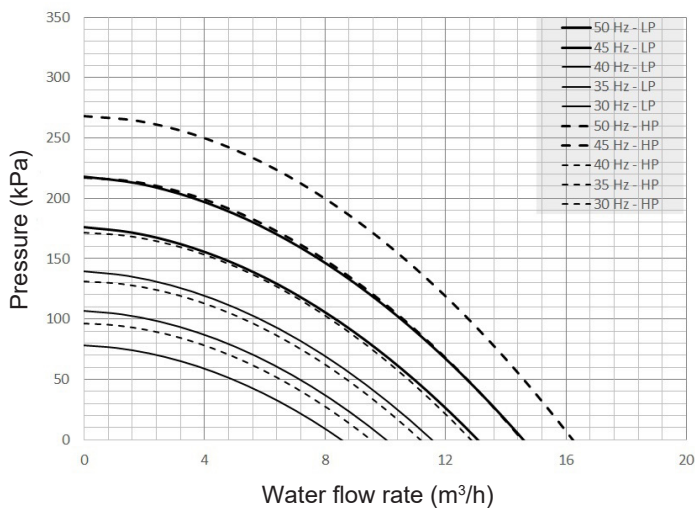

**GAC/H 040S - GAC 045S
GBC/H 040S**

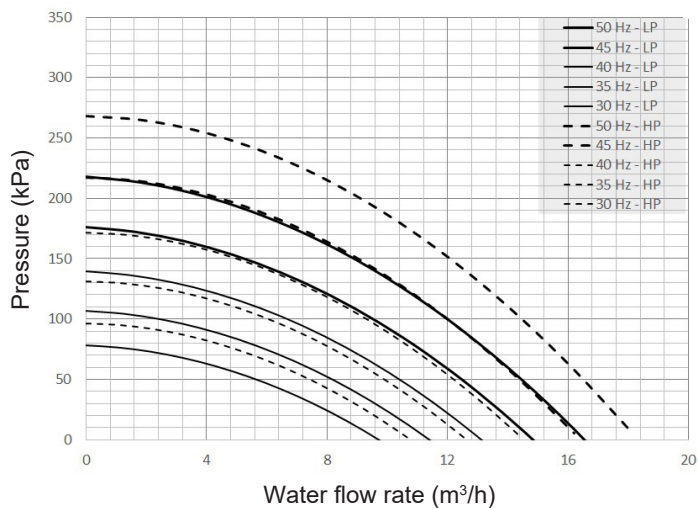

GAH 045S - GAC/H 050S - GAC 055S

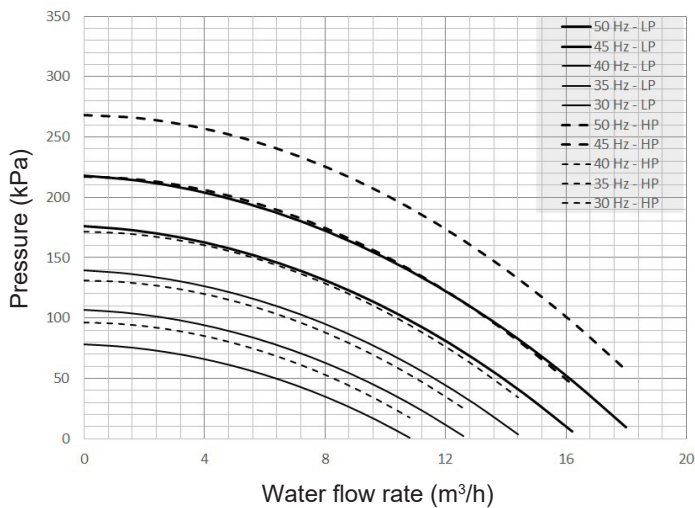

**GAH 055S - GAC 060S
GBC 060S**

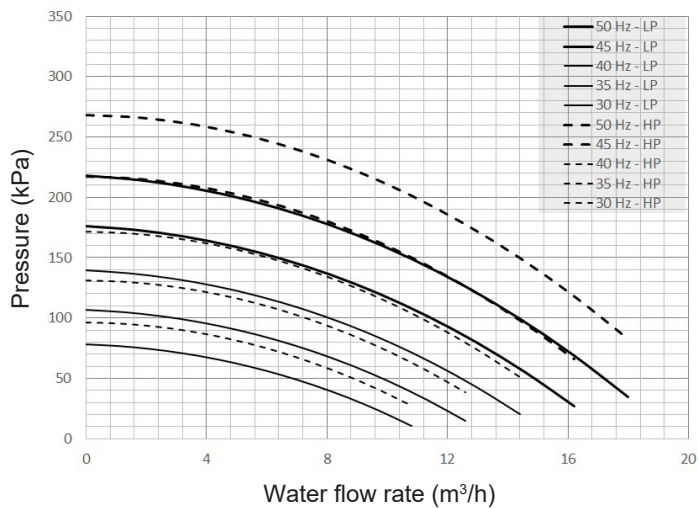

1.- GENERAL CHARACTERISTICS

1.4.- HYDRAULIC SYSTEM DATA

WATER FLOW AND AVAILABLE STATIC PRESSURE OF WATER PUMP

**GAH 060S
GBH 060S**

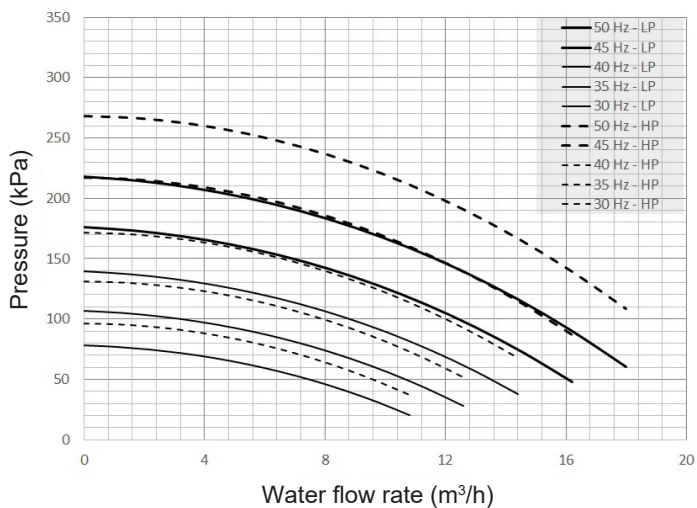

**GAC/H 065S - 070S
GBC/H 070S**

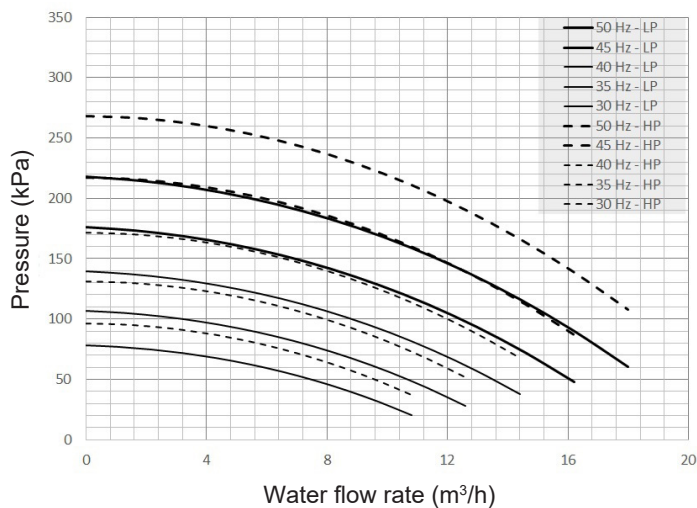

**GAC/H 080S
GBC/H 080S**

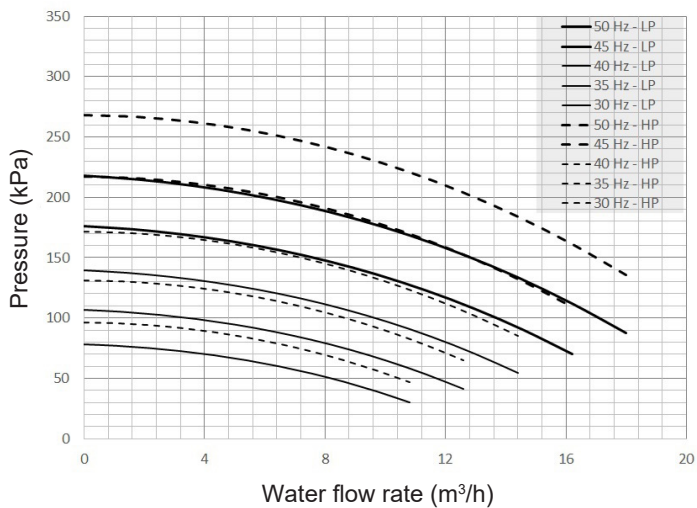

GAC/H 095S

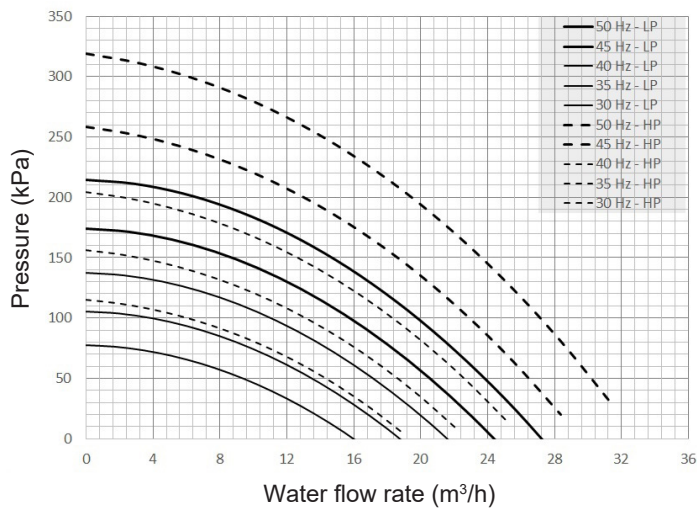

1.- GENERAL CHARACTERISTICS

1.4.- HYDRAULIC SYSTEM DATA

WATER FLOW AND AVAILABLE STATIC PRESSURE OF WATER PUMP

**GAC/H 110S - 115S
GBC/H 110S**

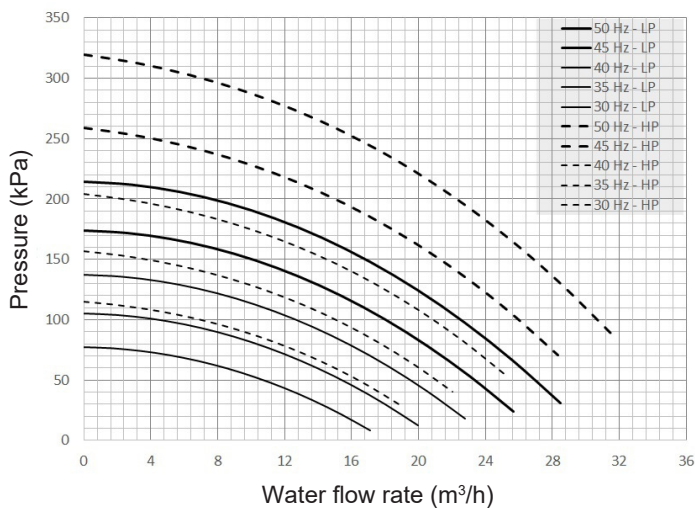

**GAC/H 125S - 140S
GBC/H 120S**

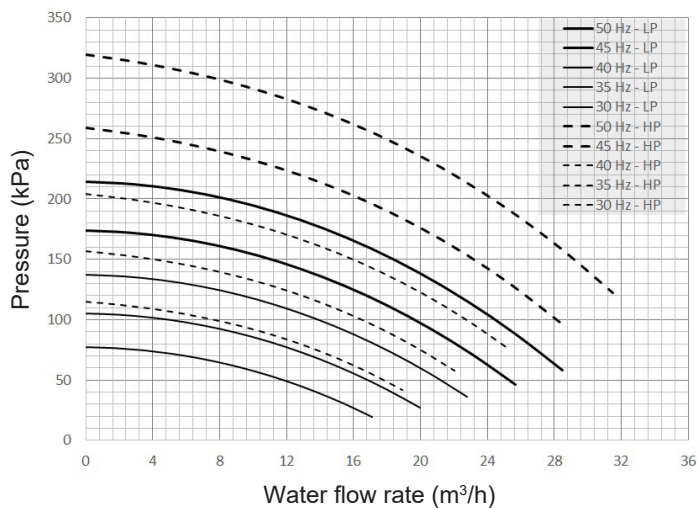

**GAC/H 110D - 125D
GBC/H 125D**

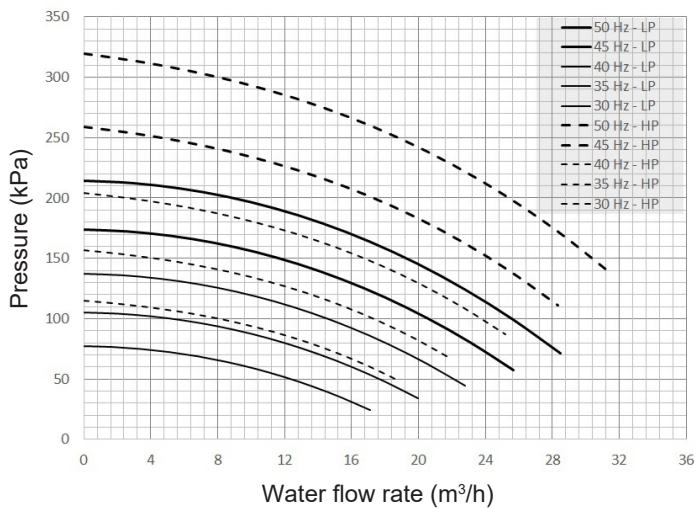

**GAC/H 140D
GBC/H 140D**

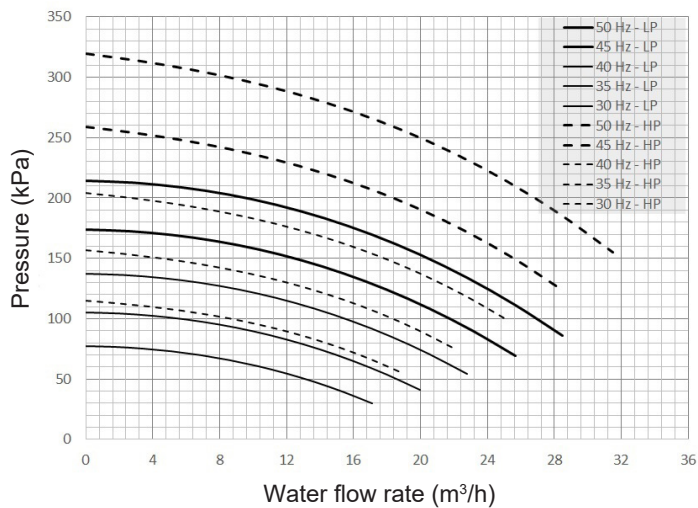

1.- GENERAL CHARACTERISTICS

1.4.- HYDRAULIC SYSTEM DATA

WATER FLOW AND AVAILABLE STATIC PRESSURE OF WATER PUMP

**GAC/H 160D
GBC/H 160D**

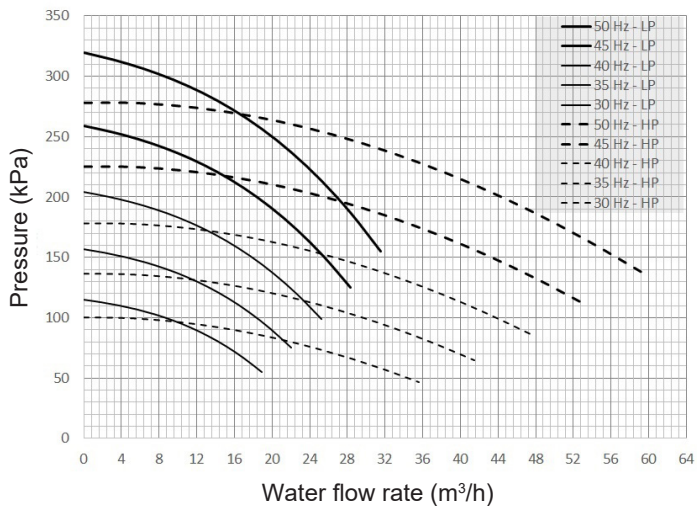

**GAC/H 185D - 210D
GBC/H 185D - 210D**

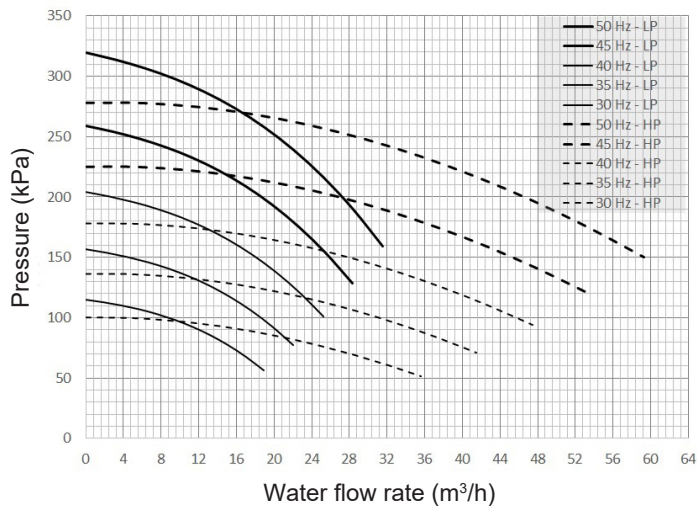

1.- GENERAL CHARACTERISTICS

1.5.- PRESSURE DROP IN THE WATER SYSTEM

BASIC UNITS - Pressure drop of the unit without water filter

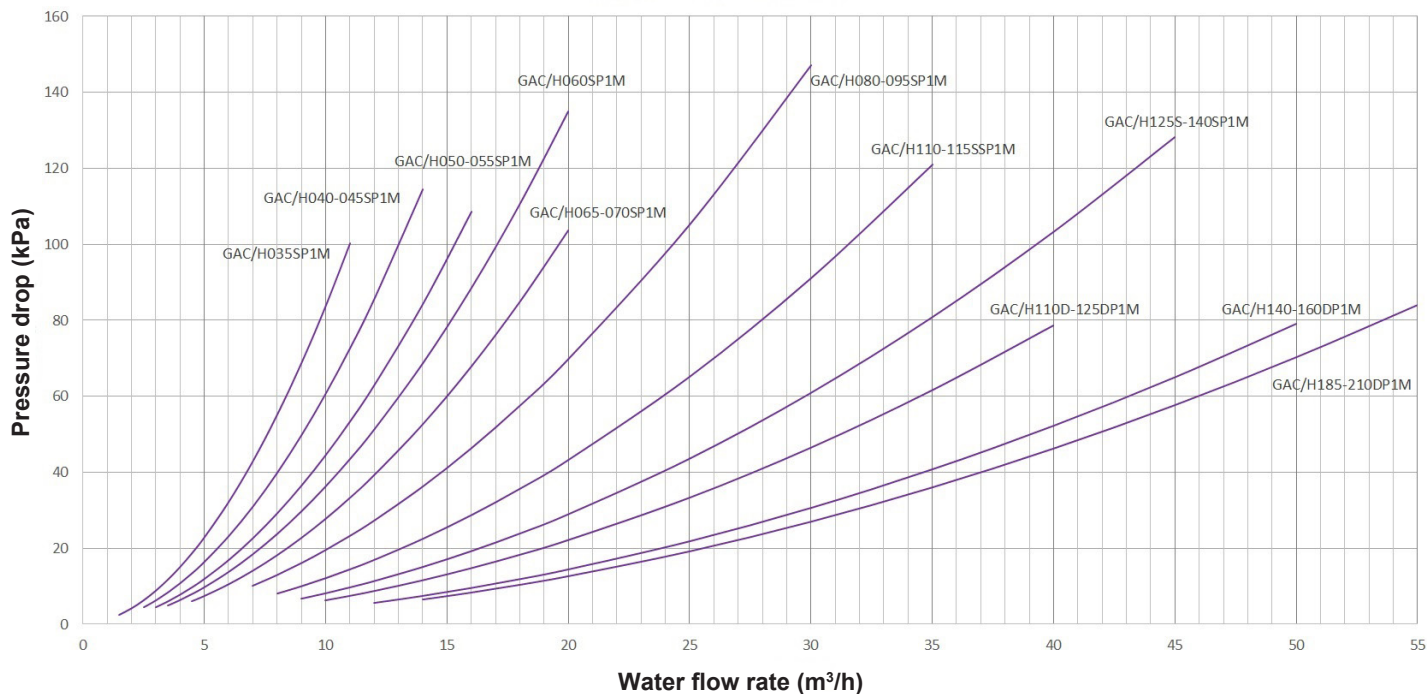

BASIC UNITS - Pressure drop for option water filter

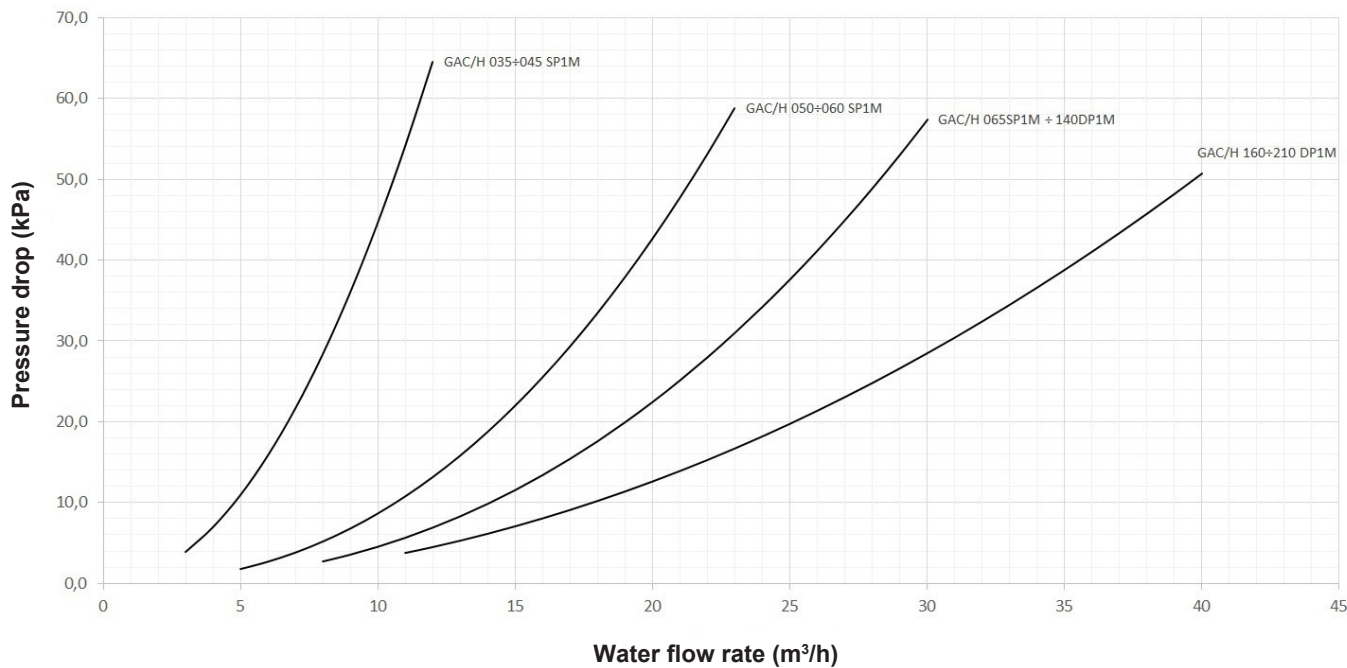

1.- GENERAL CHARACTERISTICS

1.5.- PRESSURE DROP IN THE WATER SYSTEM

ADVANCED UNITS - Pressure drop of the unit without water filter

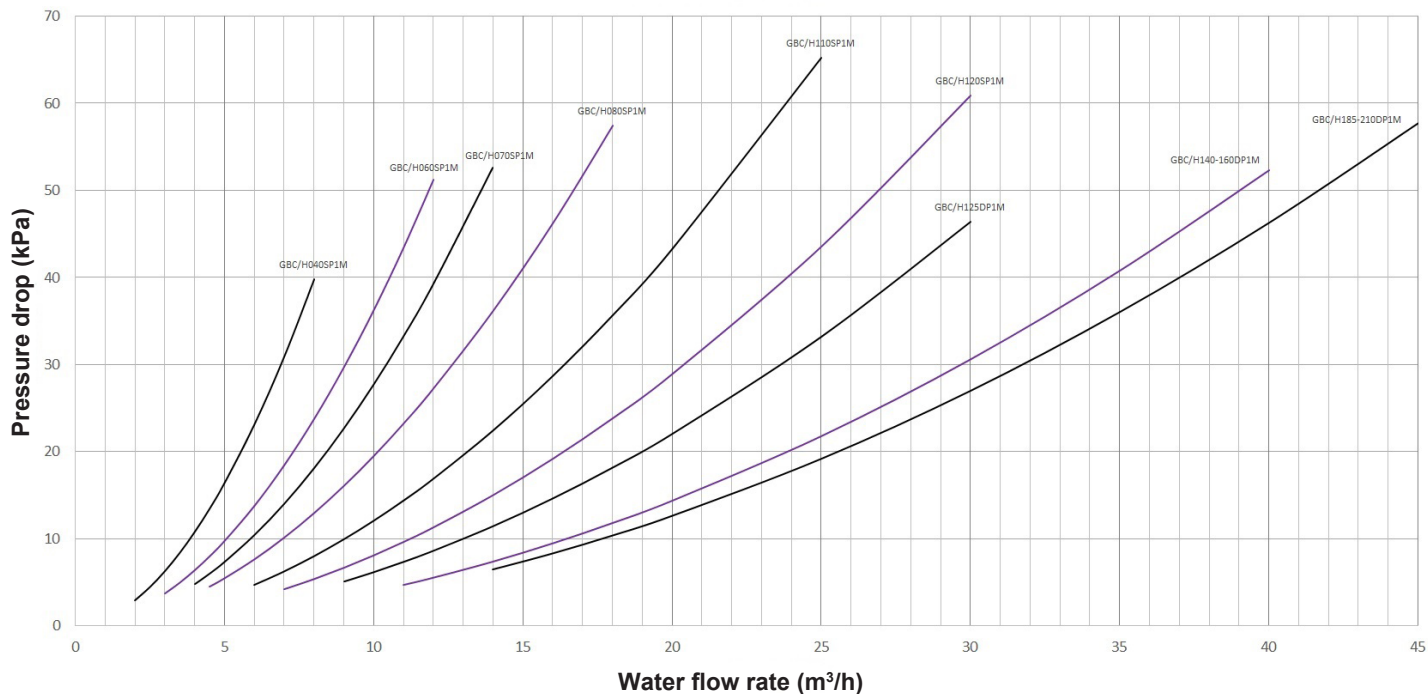

ADVANCED UNITS - Pressure drop for option water filter

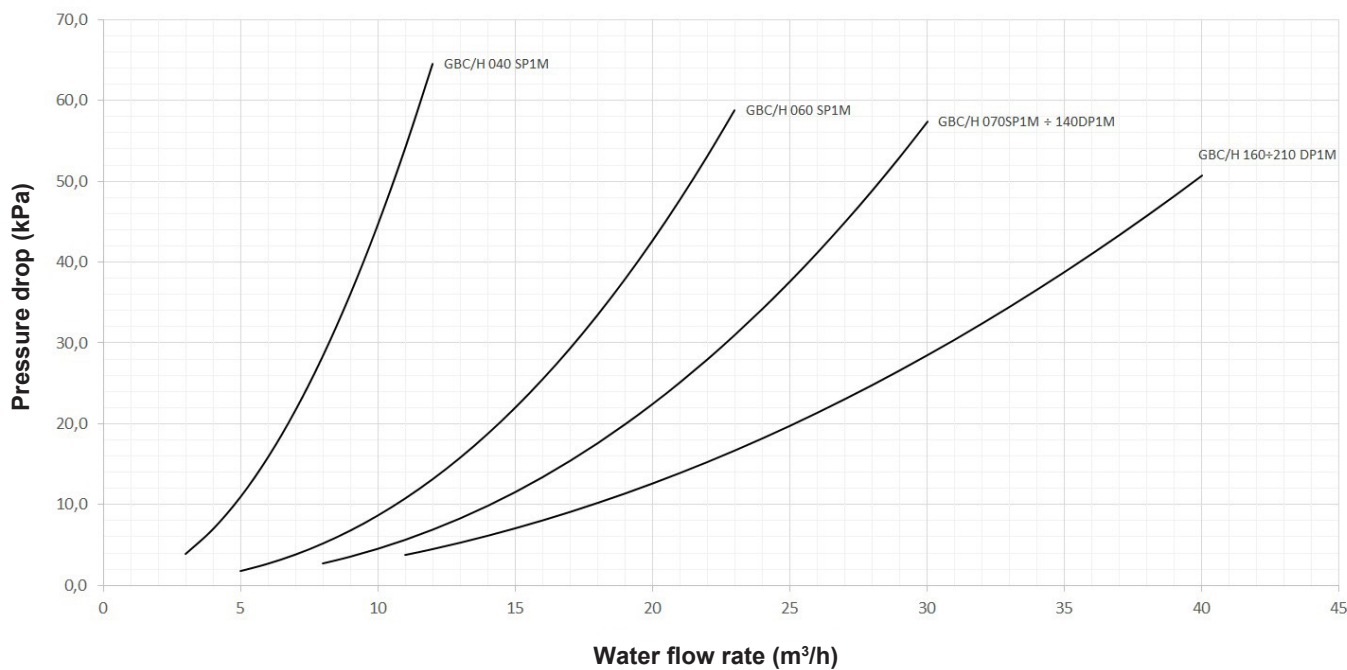

1.- GENERAL CHARACTERISTICS

1.6.- WATER FLOW

UNIT MODEL	WATER FLOW RATE (m ³ /h)			WATER CONTENT (dm ³)	
	MINIMUM	NOMINAL	MAXIMUM	UNIT WITHOUT BUFFER TANK	BUFFER TANK
GAC 035S	3,31	6,61	10,97	3,9	100
GAC 040S	3,57	7,15	11,86	4,5	100
GAC 045S	4,09	8,17	13,57	4,5	100
GAC 050S	4,45	8,90	14,78	5,3	100
GAC 055S	4,73	9,47	15,71	5,3	100
GAC 060S	5,47	10,94	18,16	5,9	N/A
GAC 065S	5,53	11,05	18,35	7,4	173
GAC 070S	6,02	12,03	19,98	7,4	173
GAC 080S	7,42	14,84	24,64	7,4	173
GAC 095S	8,24	16,48	27,35	7,9	173
GAC 110S	9,31	18,63	30,92	9,7	173
GAC 115S	10,26	20,53	34,08	9,7	173
GAC 125S	11,08	22,15	36,77	11,7	250
GAC 140S	13,44	26,89	44,64	11,7	250
GAC 110D	9,58	19,16	31,81	12,0	250
GAC 125D	10,96	21,93	36,40	12,0	250
GAC 140D	12,24	24,48	40,63	15,8	250
GAC 160D	14,43	28,86	47,91	16,3	325
GAC 185D	16,10	32,19	53,44	17,9	325
GAC 210D	18,10	36,20	60,00	17,9	325
GAH 035S	3,25	6,49	10,77	3,9	100
GAH 040S	3,54	7,09	11,77	4,5	100
GAH 045S	4,03	8,07	13,39	5,3	100
GAH 050S	4,34	8,69	14,42	5,3	100
GAH 055S	4,82	9,65	16,01	5,9	100
GAH 060S	5,44	10,87	18,05	6,9	N/A
GAH 065S	5,53	11,06	18,35	7,4	173
GAH 070S	5,99	11,98	19,88	7,4	173
GAH 080S	7,29	14,57	24,19	7,4	173
GAH 095S	8,09	16,19	26,87	7,9	173
GAH 110S	9,06	18,12	30,07	9,7	173
GAH 115S	10,15	20,29	33,68	9,7	173
GAH 125S	10,87	21,74	36,09	11,7	250
GAH 140S	13,07	26,14	43,40	11,7	250
GAH 110D	9,34	18,68	31,01	12,0	250
GAH 125D	10,77	21,55	35,77	12,0	250
GAH 140D	12,07	24,13	40,06	15,8	250
GAH 160D	14,28	28,56	47,41	16,3	325
GAH 185D	16,11	32,21	53,47	17,9	325
GAH 210D	17,99	35,97	59,71	17,9	325

1.- GENERAL CHARACTERISTICS

1.6.- WATER FLOW

UNIT MODEL	WATER FLOW RATE (m ³ /h)			WATER CONTENT (dm ³)	
	MINIMUM	NOMINAL	MAXIMUM	UNIT WITHOUT BUFFER TANK	BUFFER TANK
GBC 040S	2,97	5,94	7,72	4,538	100
GBC 060S	4,41	8,83	11,47	6,856	100
GBC 070S	5,29	10,58	13,75	7,356	173
GBC 080S	6,66	13,32	17,31	7,356	173
GBC 110S	8,13	16,26	21,14	9,676	173
GBC 120S	10,06	20,12	26,15	11,696	173
GBC 125D	10,73	21,47	27,91	11,99	250
GBC 140D	12,62	25,24	32,81	15,77	250
GBC 160D	13,72	27,44	35,67	16,27	325
GBC 185D	14,62	29,23	38	17,89	325
GBC 210D	16,91	33,82	43,96	17,89	325
GBH 040S	2,89	5,78	7,51	4,538	100
GBH 060S	4,3	8,61	11,19	6,856	100
GBH 070S	5,21	10,43	13,55	7,356	173
GBH 080S	6,19	12,37	16,08	7,356	173
GBH 110S	7,54	15,07	19,59	9,676	173
GBH 120S	9,39	18,78	24,42	11,696	173
GBH 125D	10,62	21,25	27,62	11,99	250
GBH 140D	12,39	24,78	32,22	15,77	250
GBH 160D	13,6	27,2	35,36	16,27	325
GBH 185D	14,61	29,23	38	17,89	325
GBH 210D	16,85	33,71	43,82	17,89	325

1.- GENERAL CHARACTERISTICS

1.7.- PIPING DRAWINGS

BASIC UNITS - COOLING ONLY UNITS

GAC B-BOX 035S-040S-045S

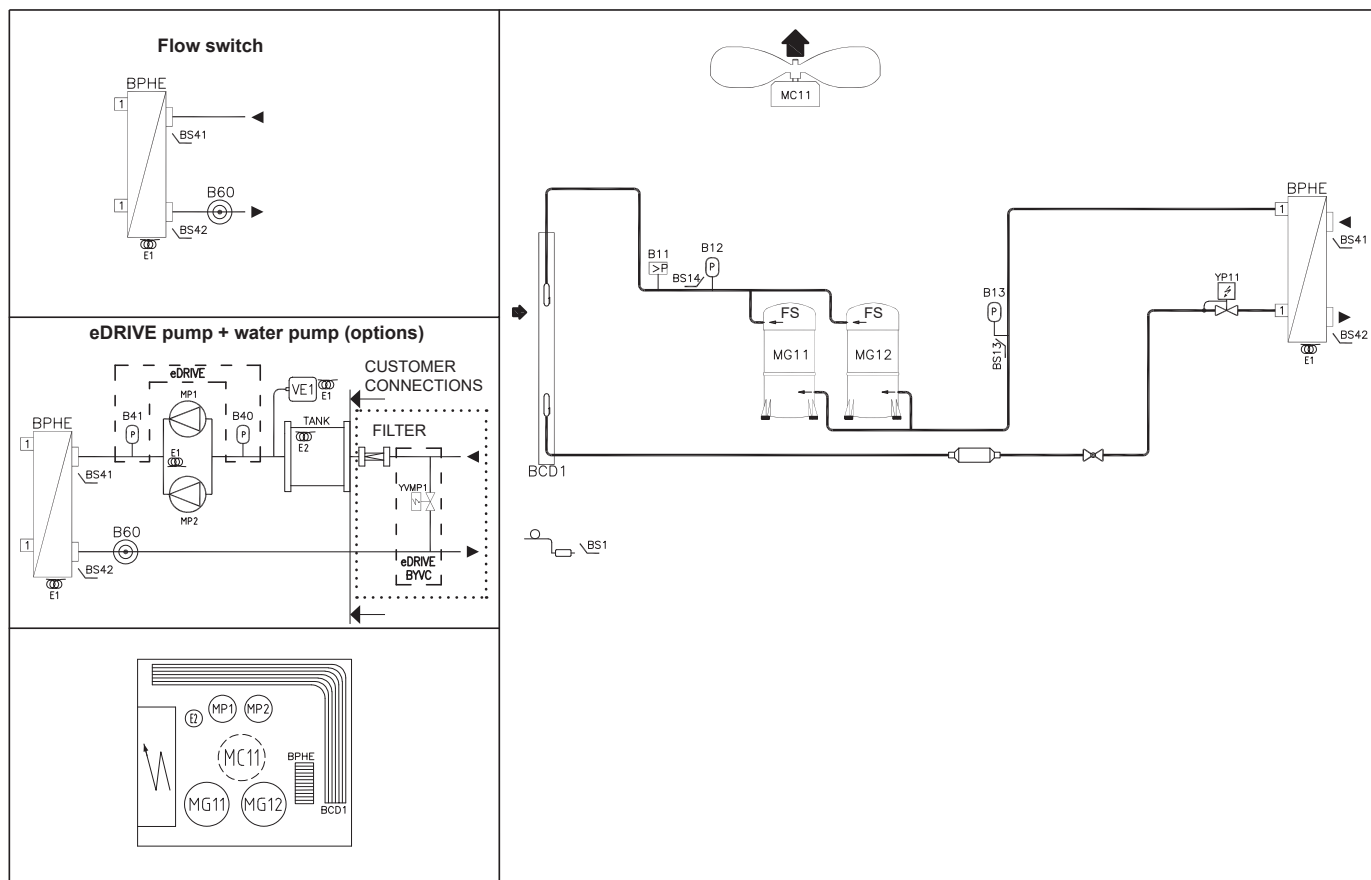

GAC B+-BOX 050S-055S-060S

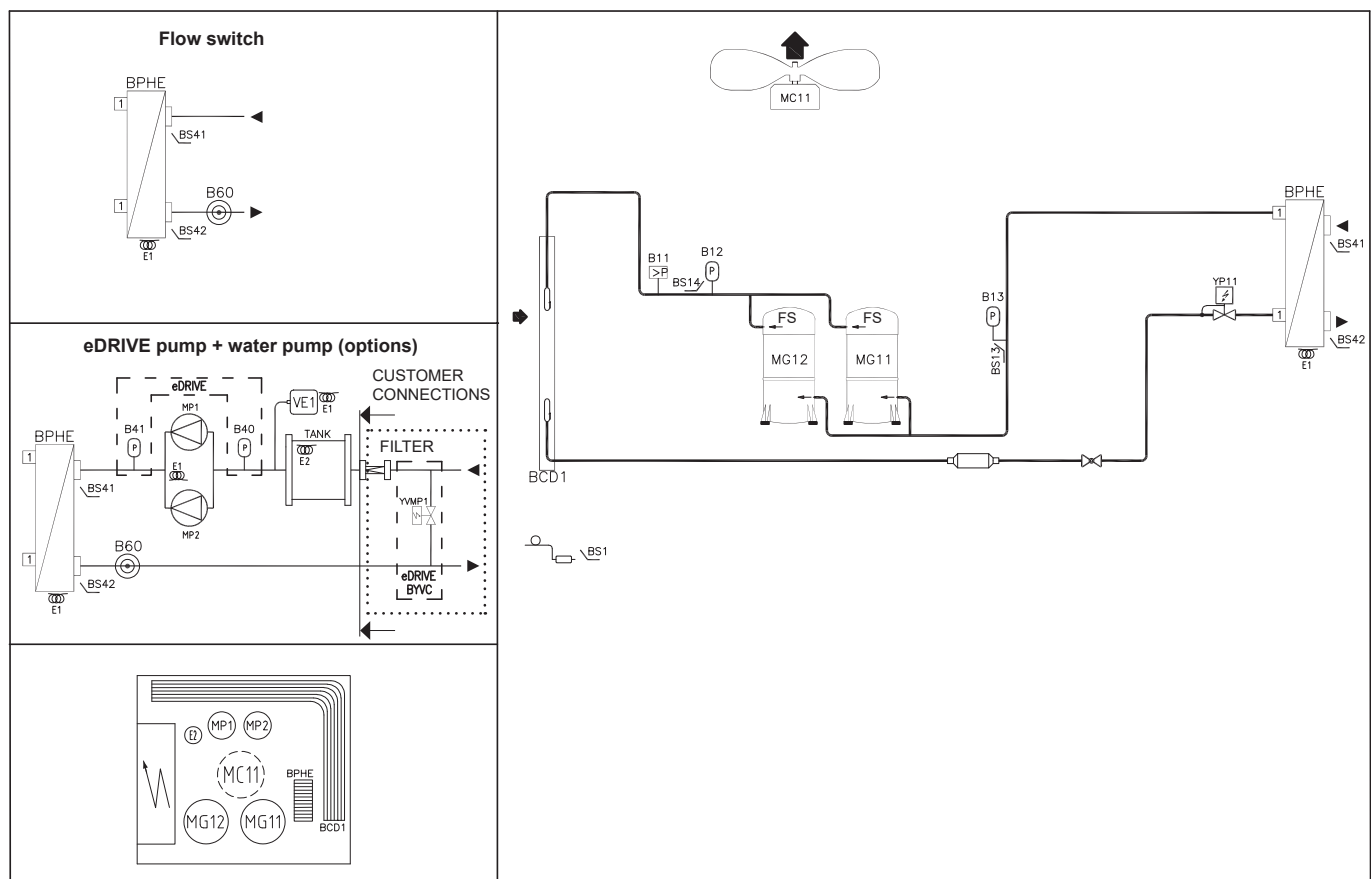

1.- GENERAL CHARACTERISTICS

1.7.- PIPING DRAWINGS

BASIC UNITS - COOLING ONLY UNITS

GAC C-BOX 065S-070S-080S

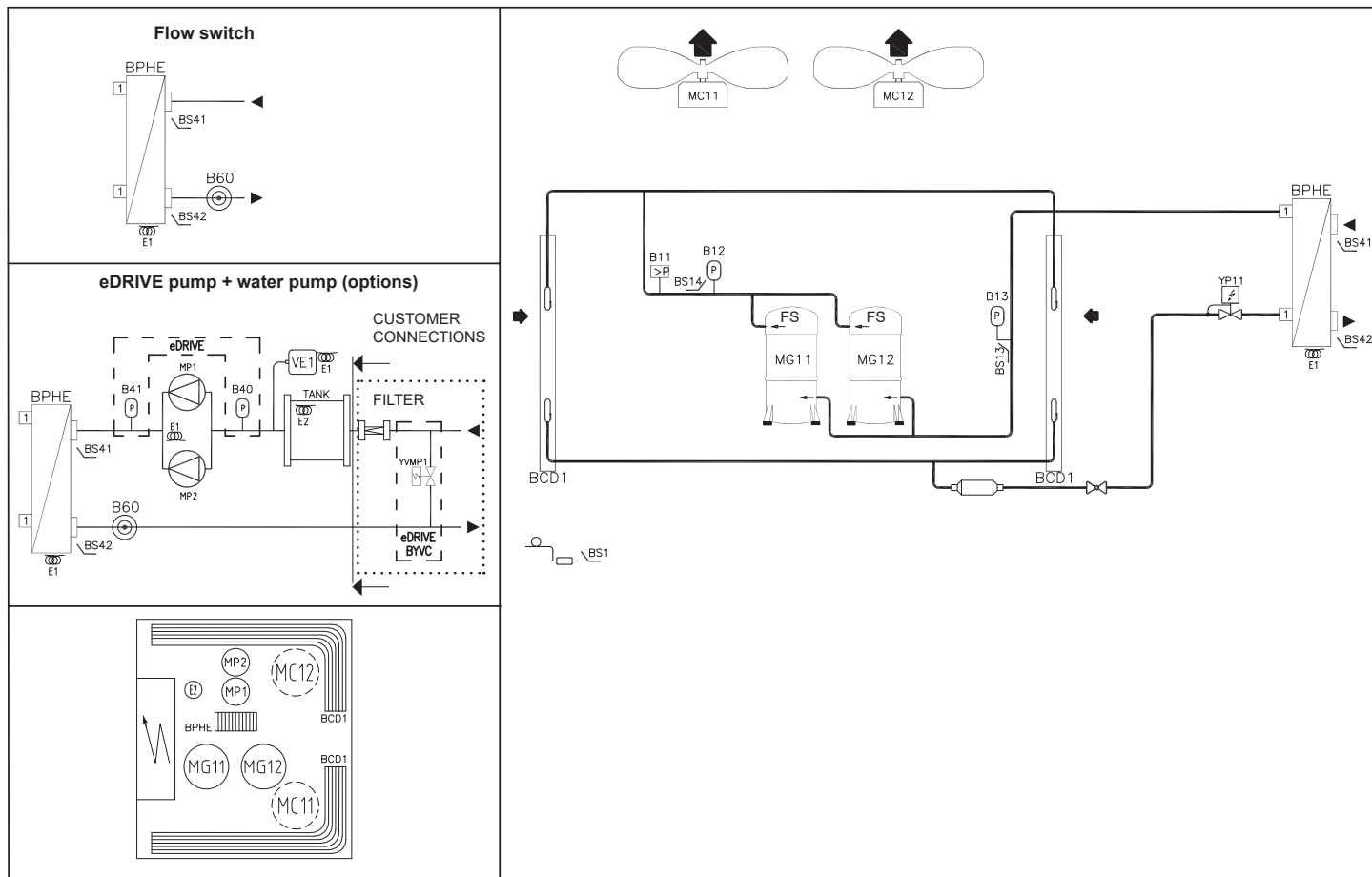

GAC C+-BOX 095S-110S

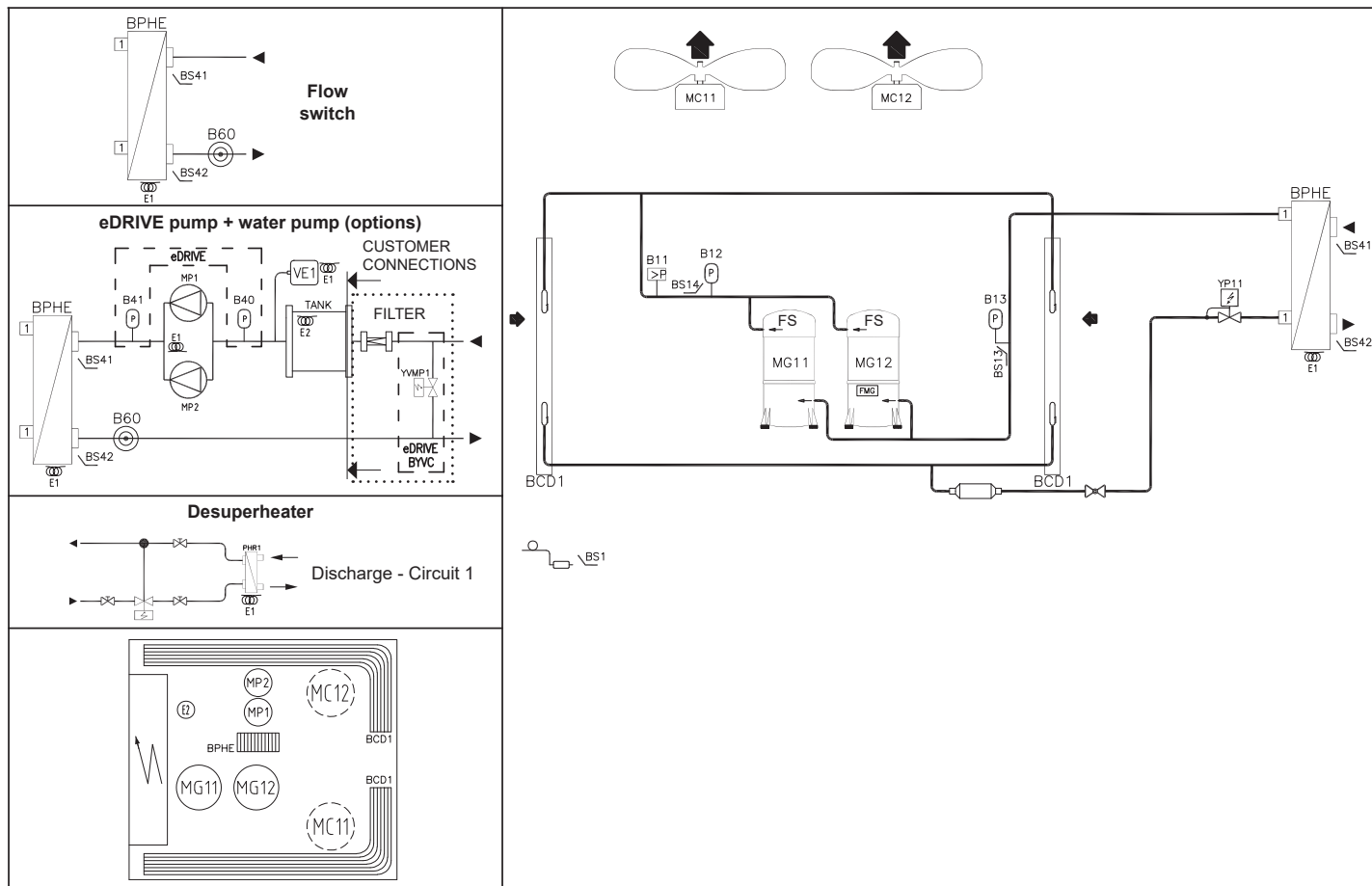

1.- GENERAL CHARACTERISTICS

1.7.- PIPING DRAWINGS

BASIC UNITS - COOLING ONLY UNITS

GAC C+BOX 115S

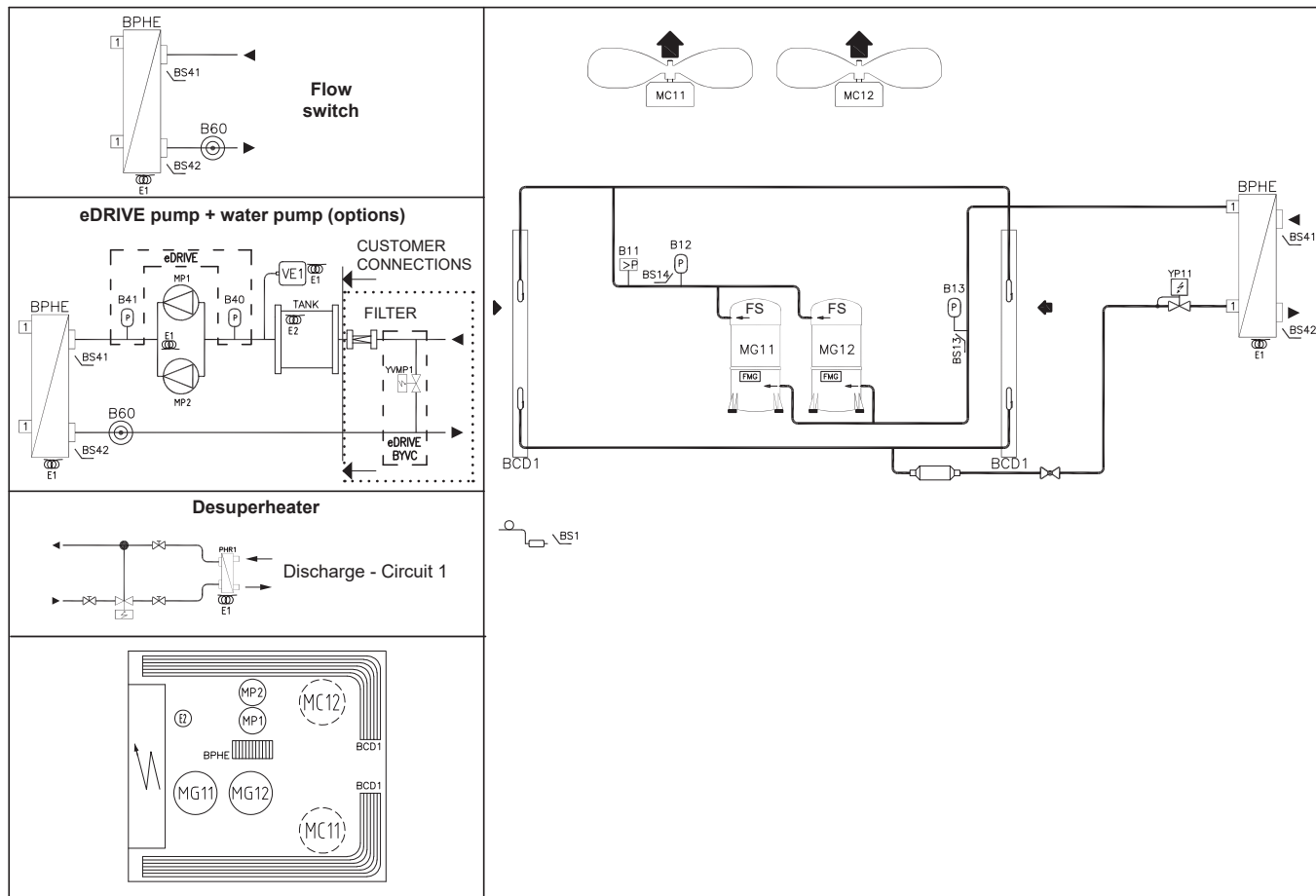

GAC D-BOX 125S

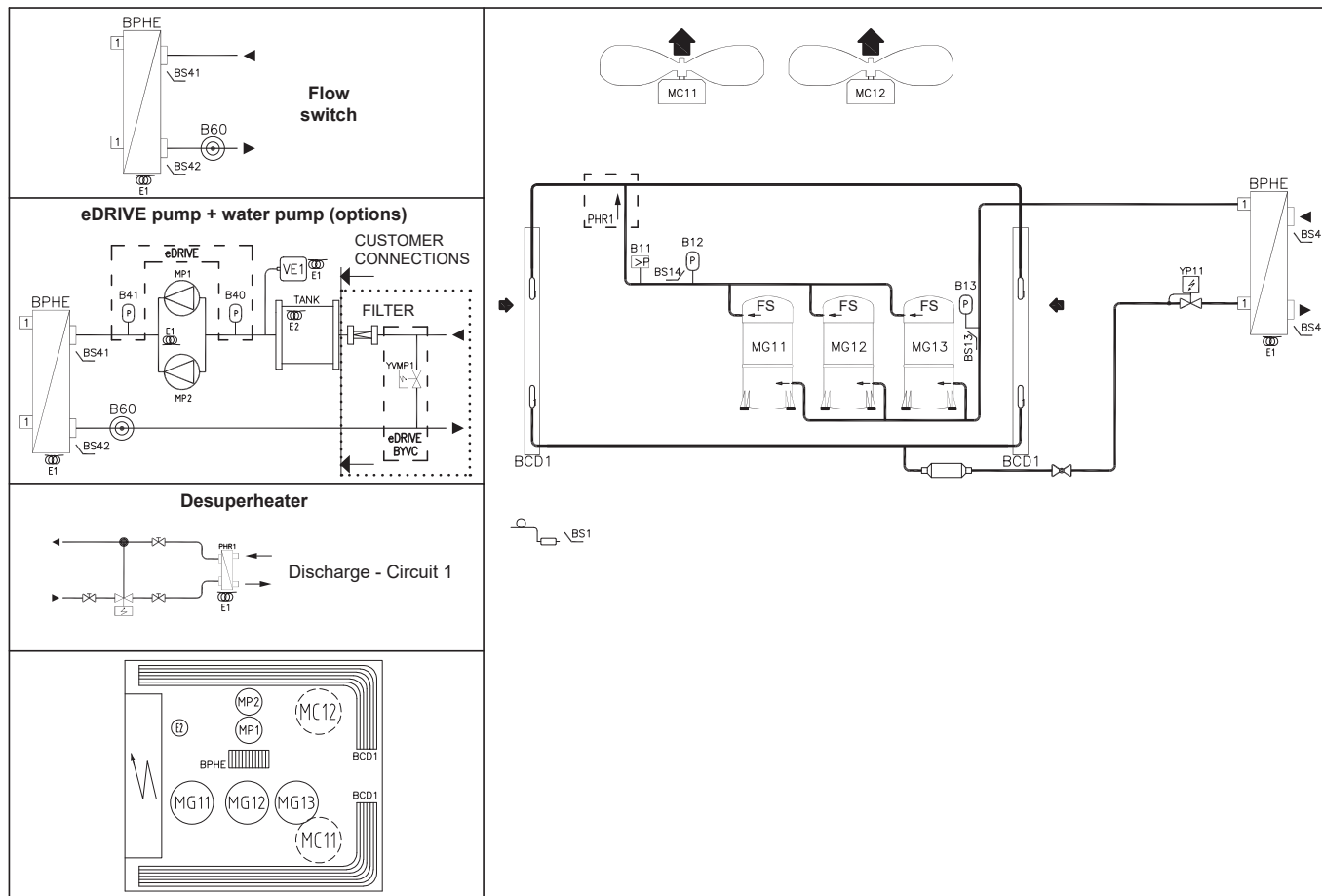

1.- GENERAL CHARACTERISTICS

1.7.- PIPING DRAWINGS

BASIC UNITS - COOLING ONLY UNITS

GAC D-BOX 140S

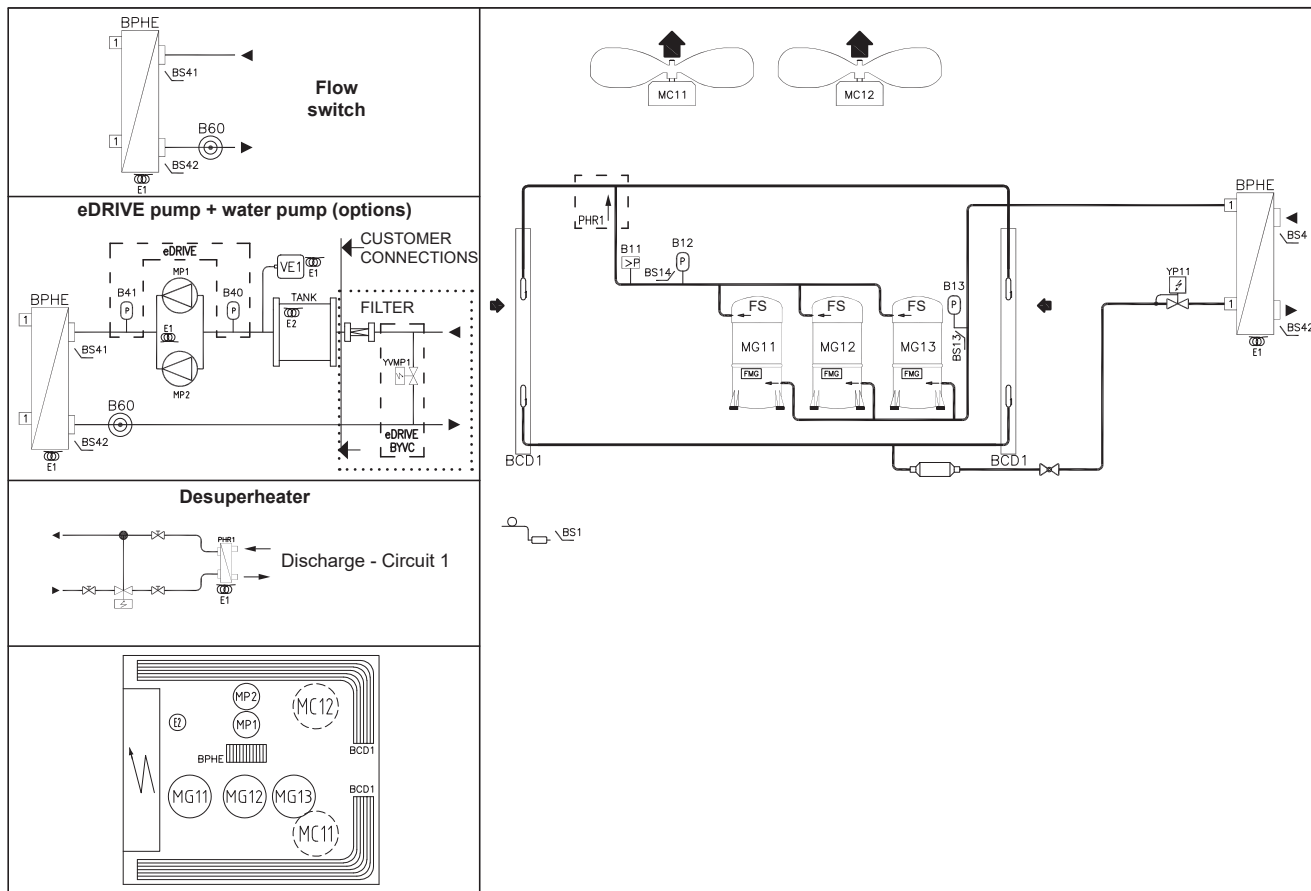

GAC D-BOX 110D-125D-140D

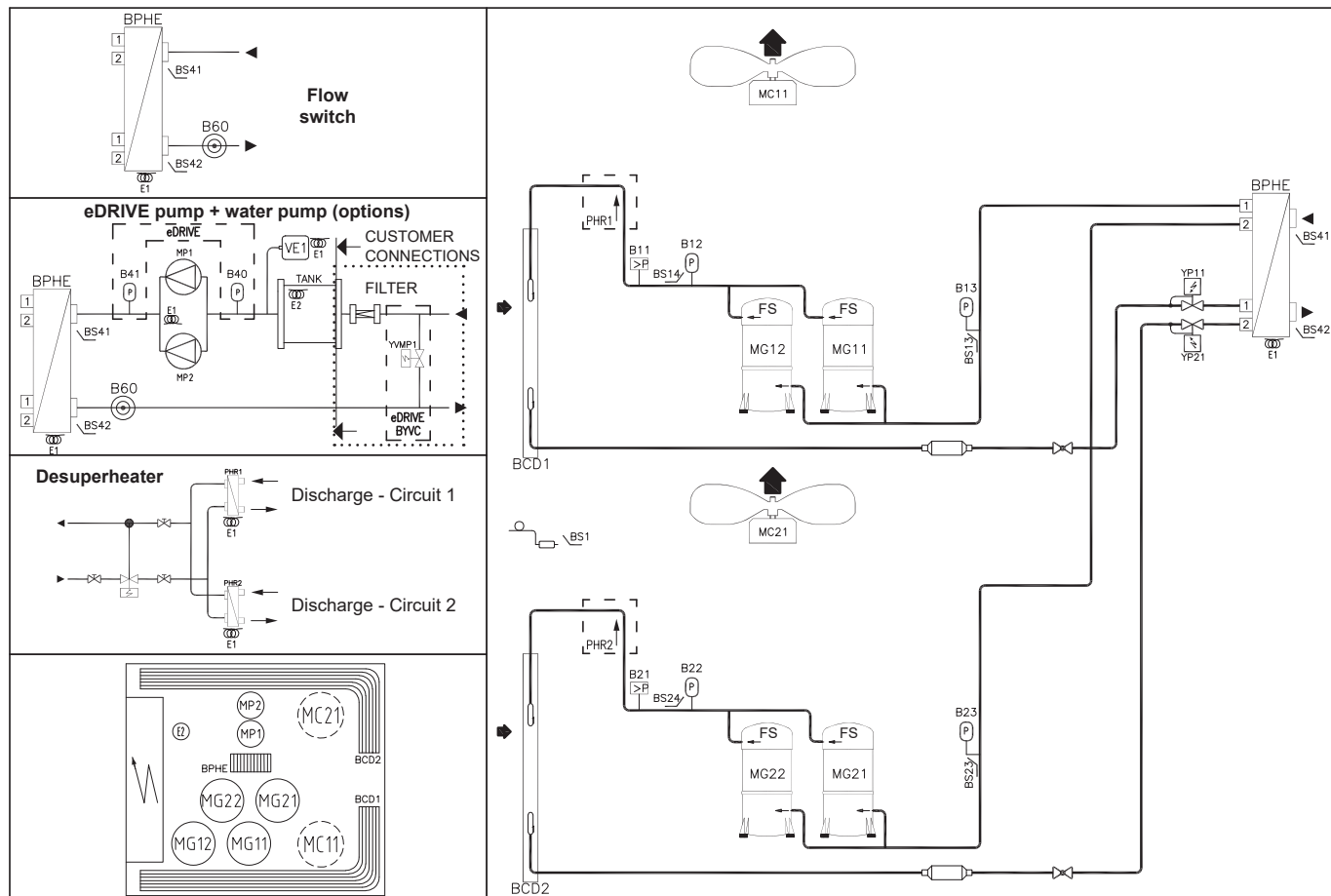

1.- GENERAL CHARACTERISTICS

1.7.- PIPING DRAWINGS

BASIC UNITS - COOLING ONLY UNITS

GAC E-BOX 160D

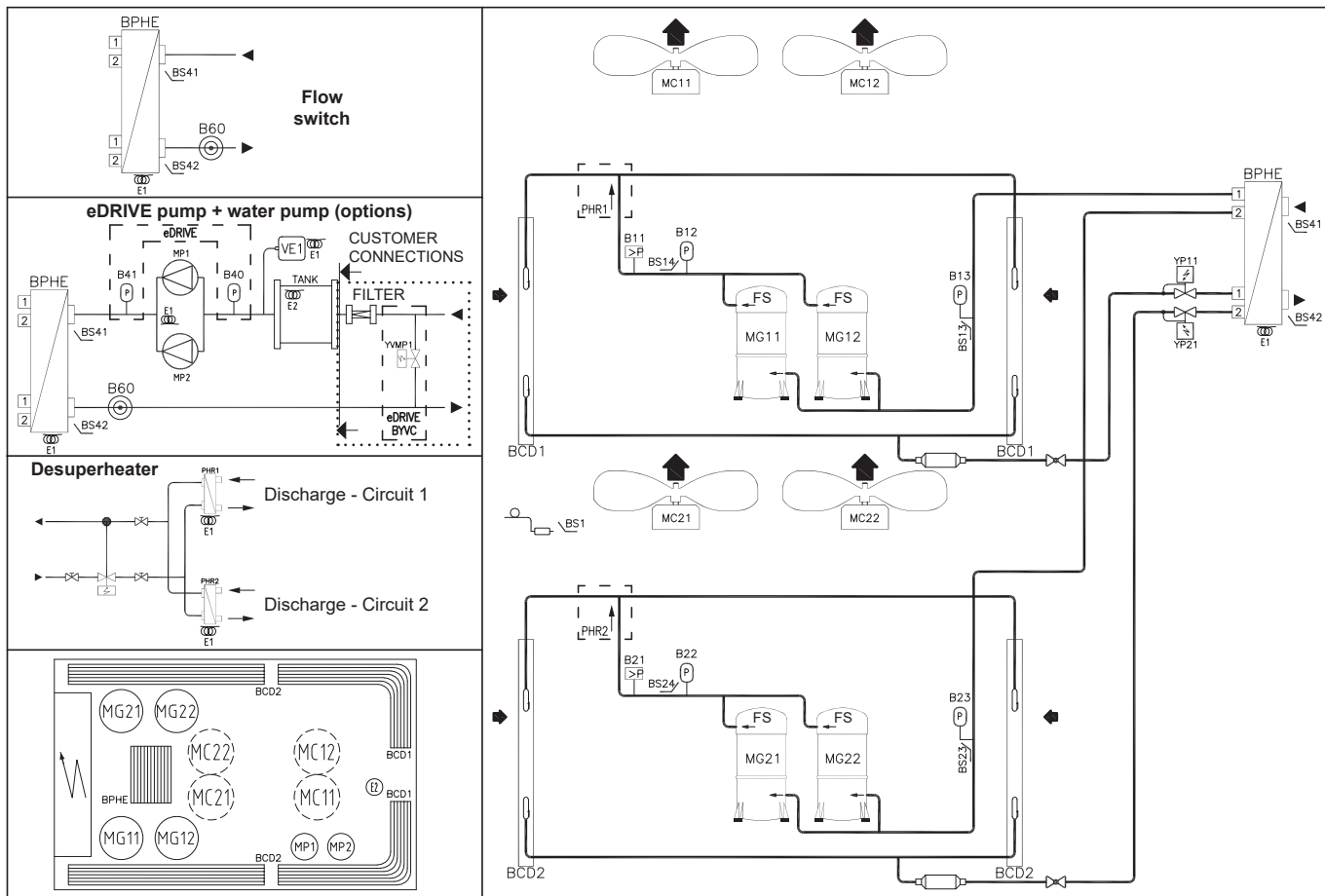

GAC E-BOX 185D-210D

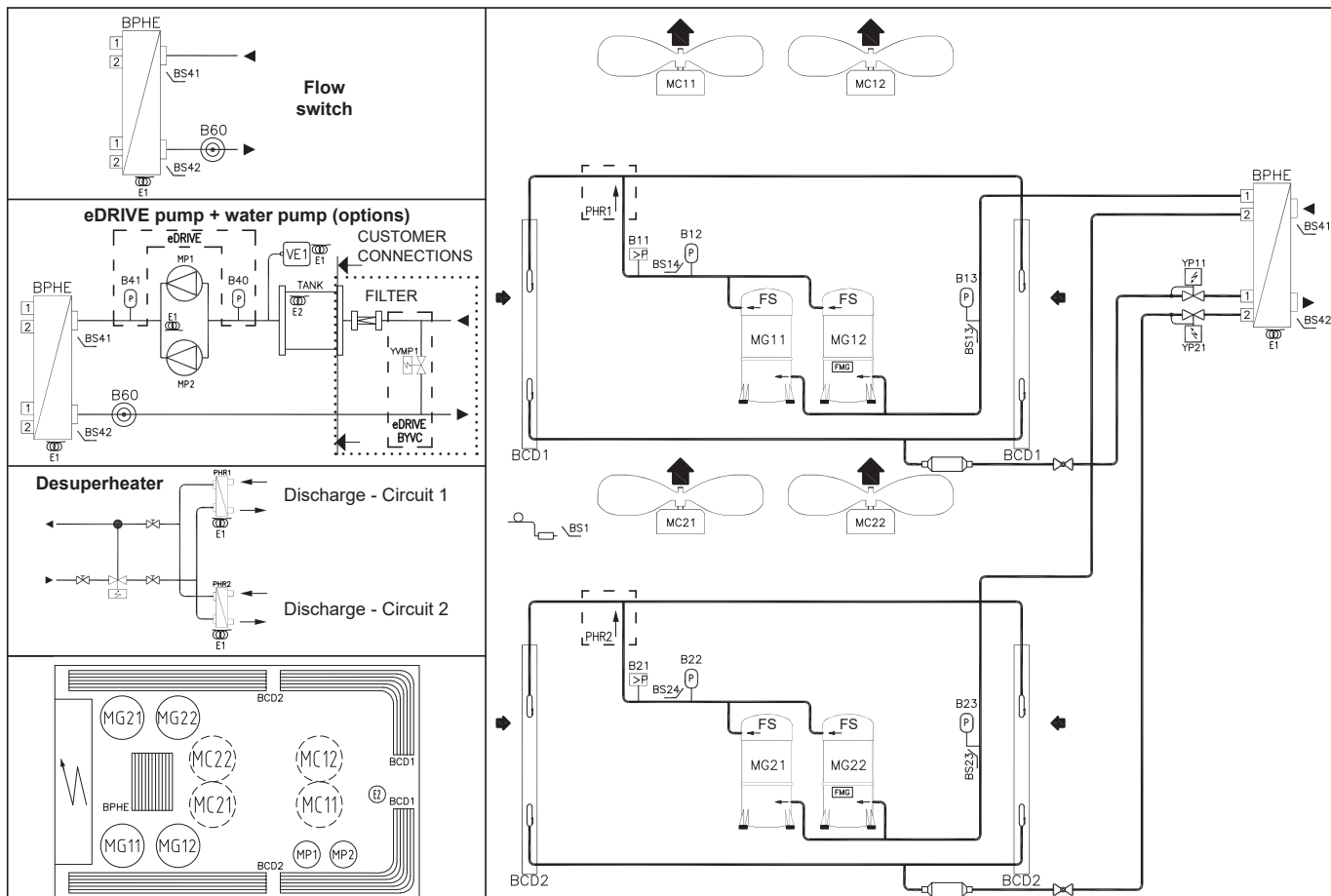

1.- GENERAL CHARACTERISTICS

1.7.- PIPING DRAWINGS

ADVANCED UNITS - COOLING ONLY UNITS

GBC B-BOX 040S

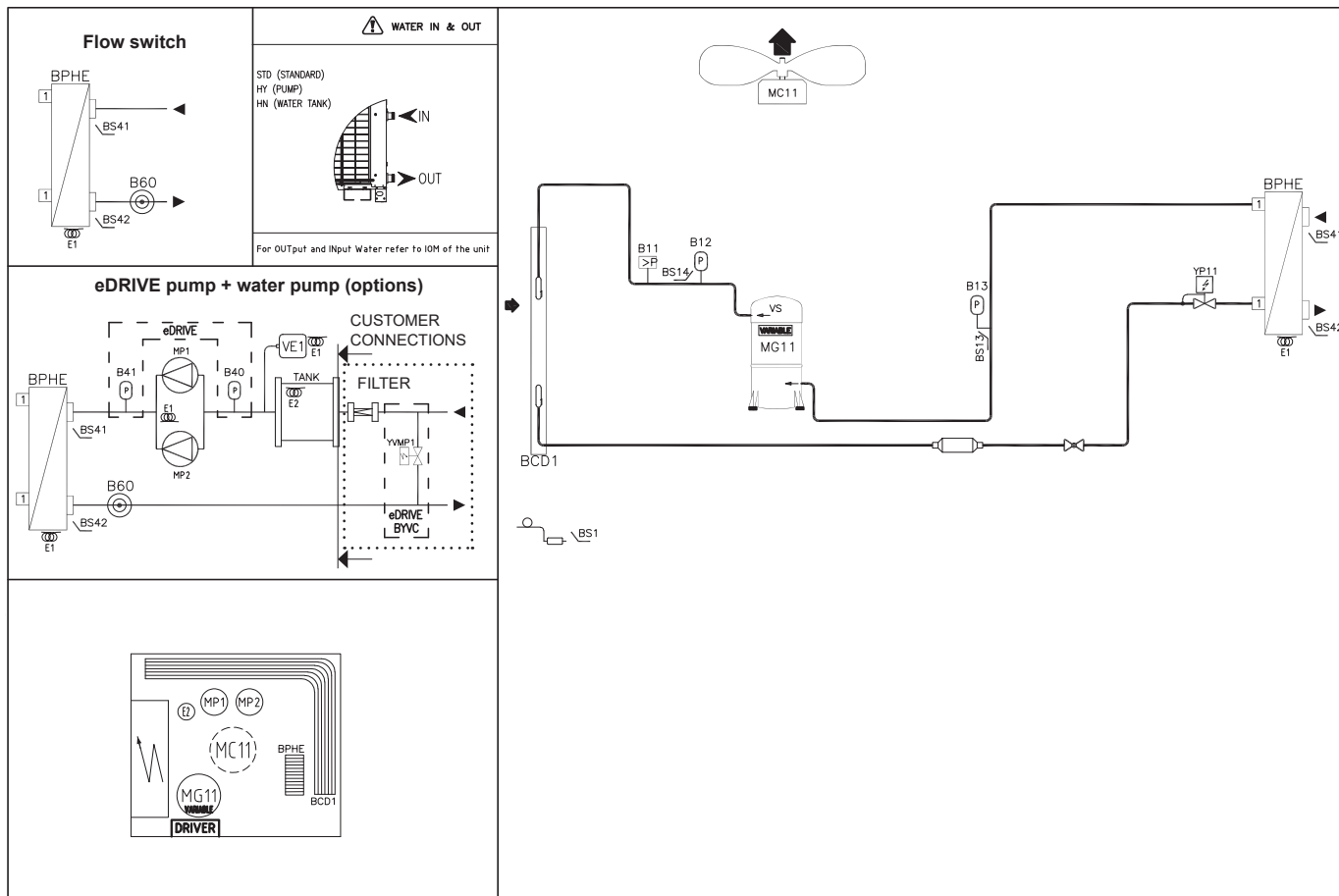

GBC B+BOX 060S

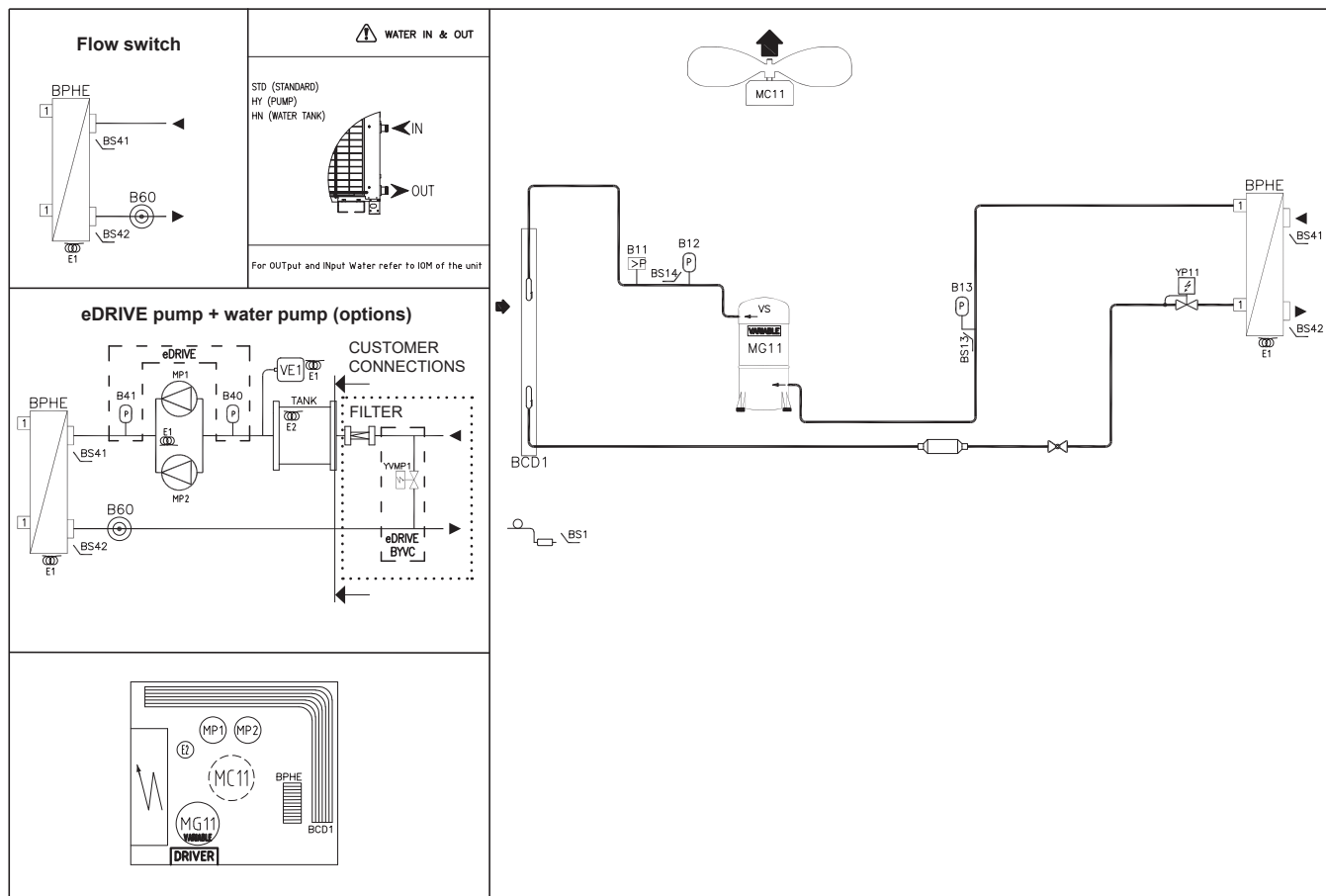

1.- GENERAL CHARACTERISTICS

1.7.- PIPING DRAWINGS

ADVANCED UNITS - COOLING ONLY UNITS

GBC C-BOX 070S-080S

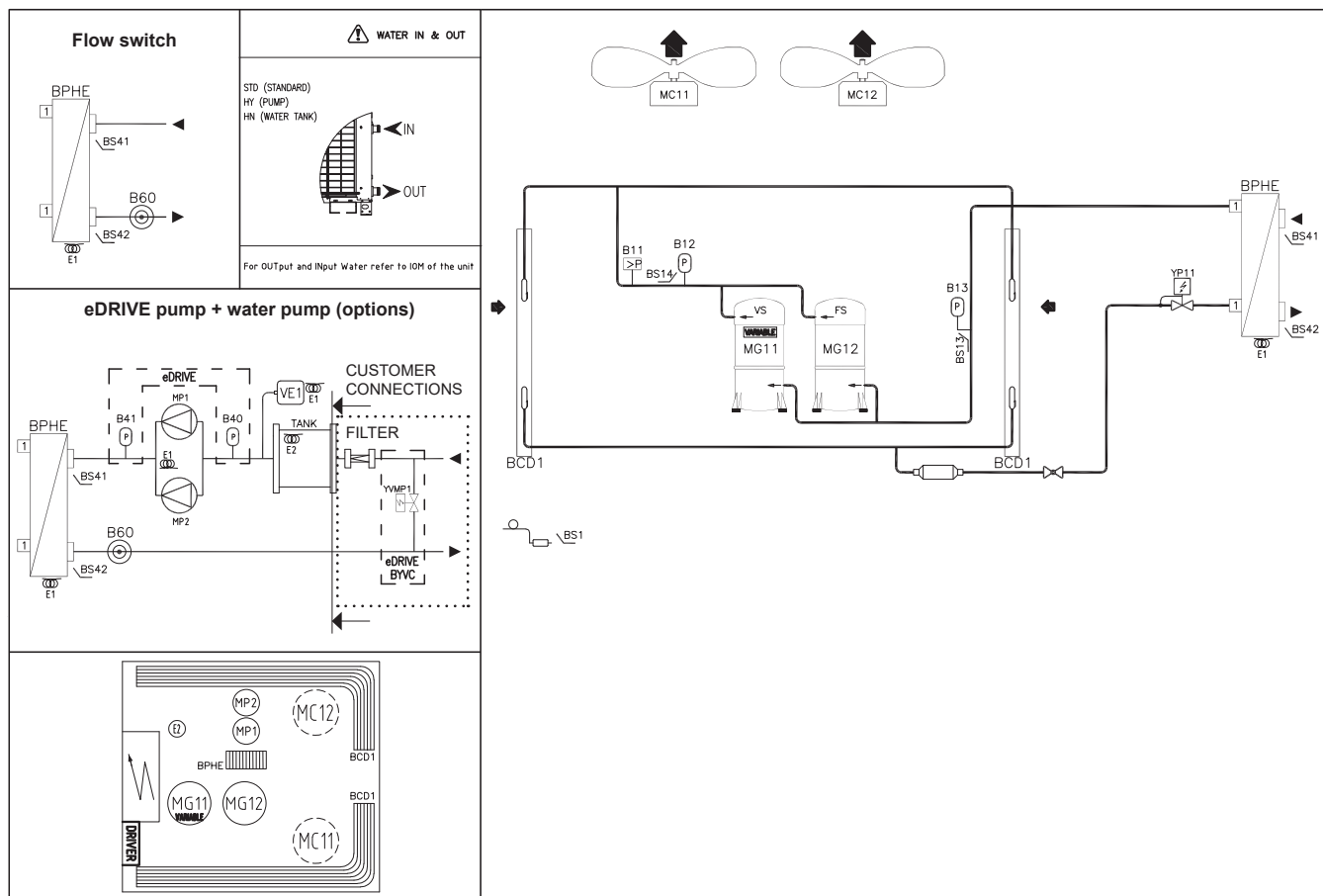

GBC C+-BOX 110S

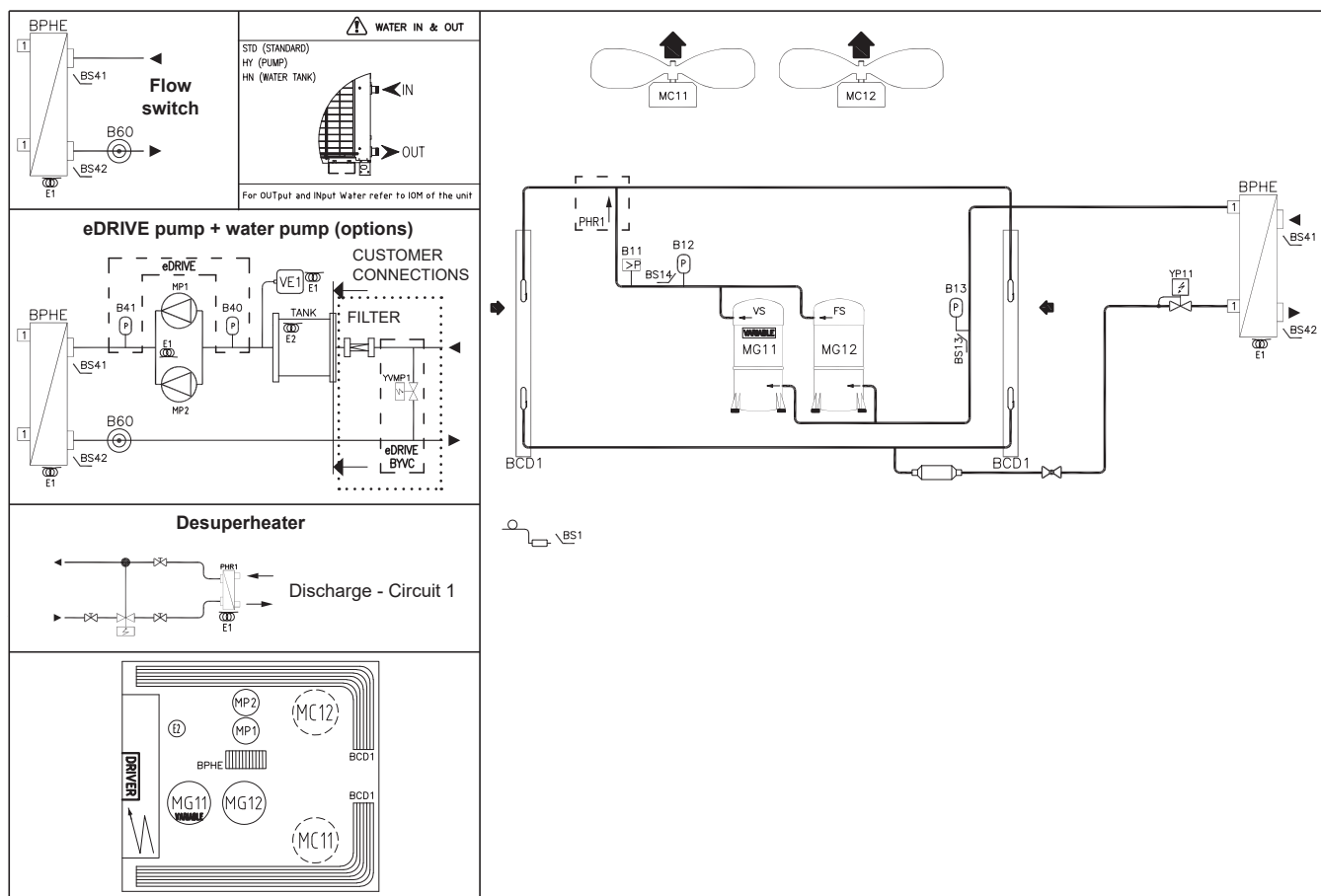

1.- GENERAL CHARACTERISTICS

1.7.- PIPING DRAWINGS

ADVANCED UNITS - COOLING ONLY UNITS

GBC C+BOX 120S

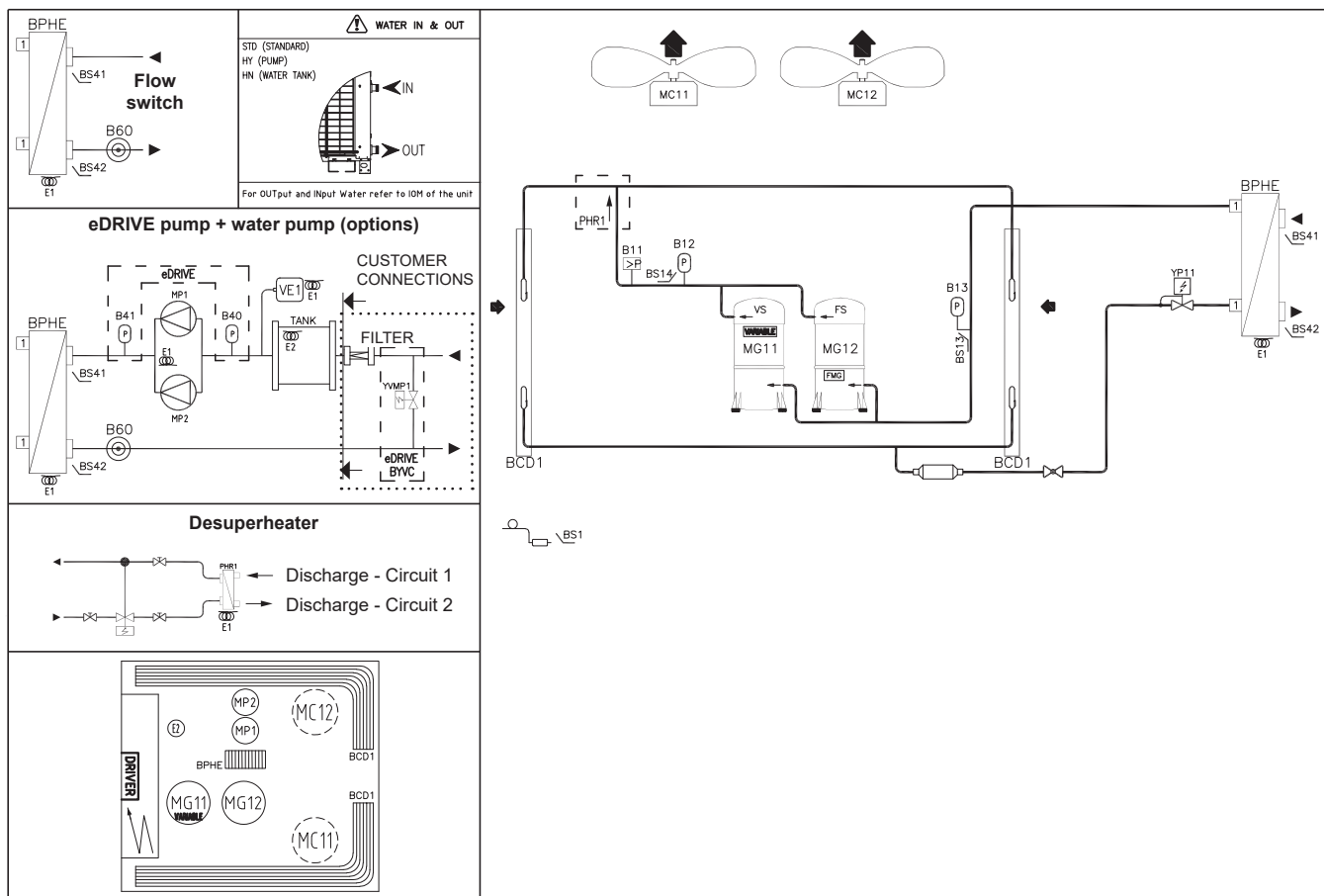

GBC D-BOX 125D-140D

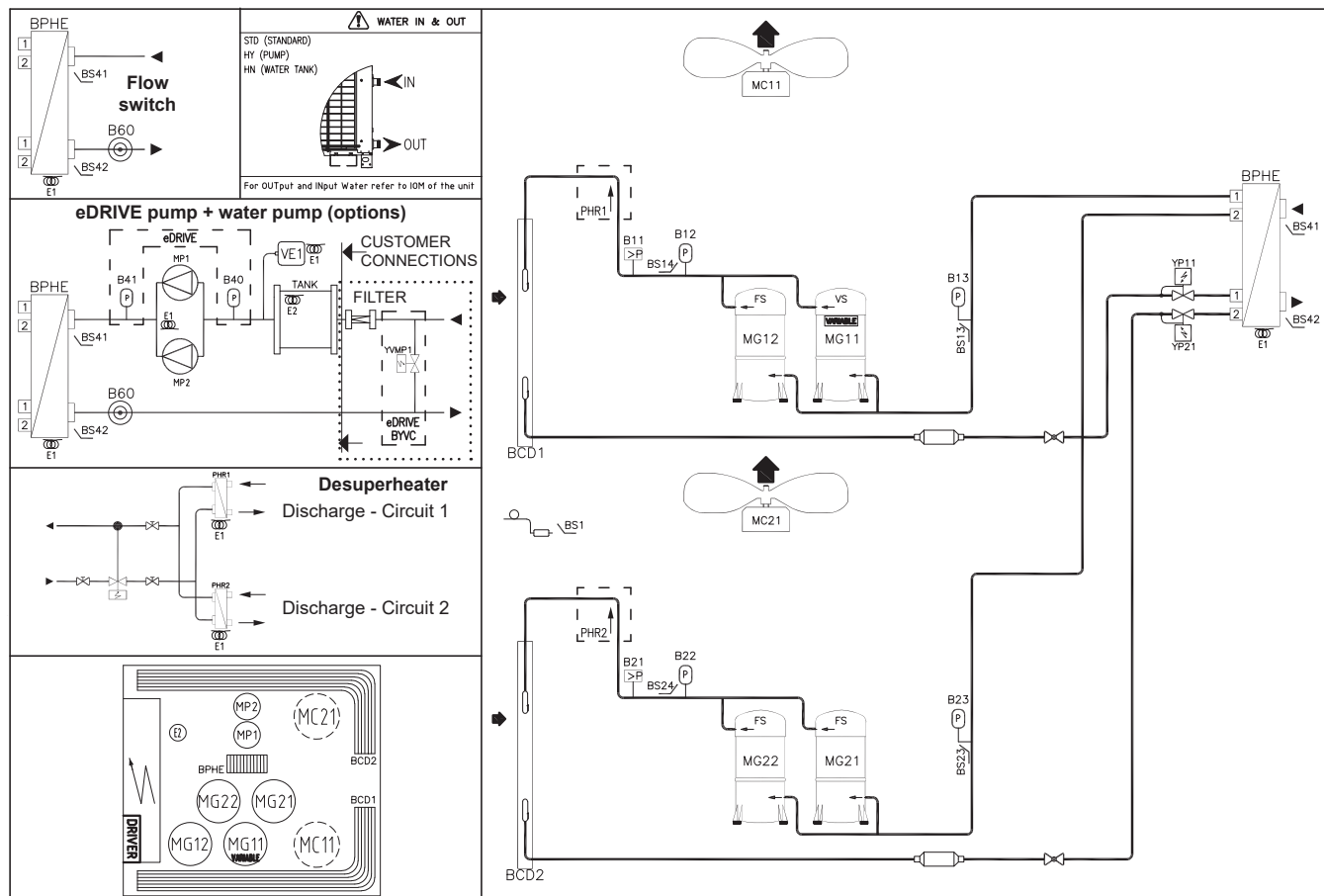

1.- GENERAL CHARACTERISTICS

1.7.- PIPING DRAWINGS

ADVANCED UNITS - COOLING ONLY UNITS

GBC E-BOX 160D

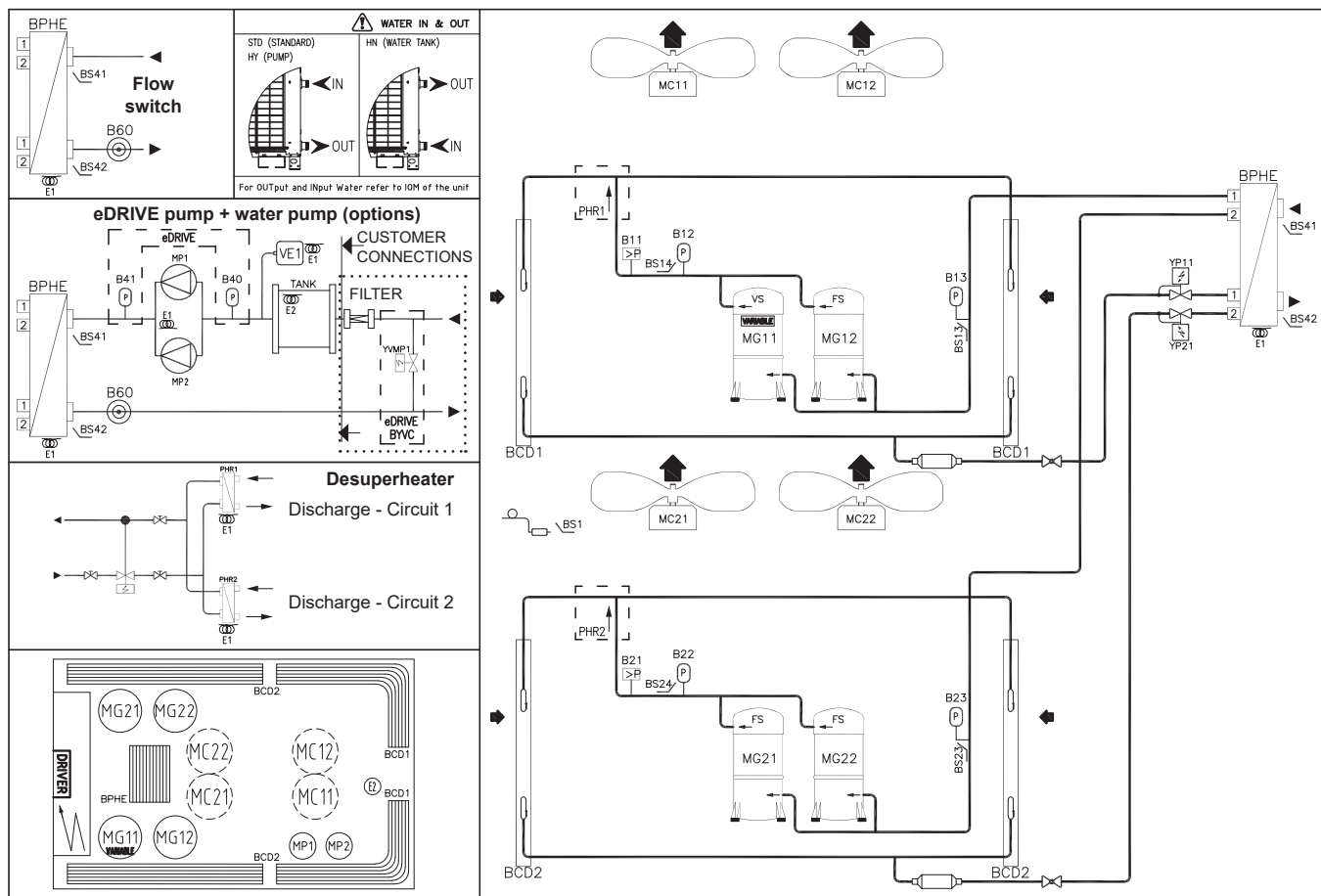

GBC E-BOX 185D-210D

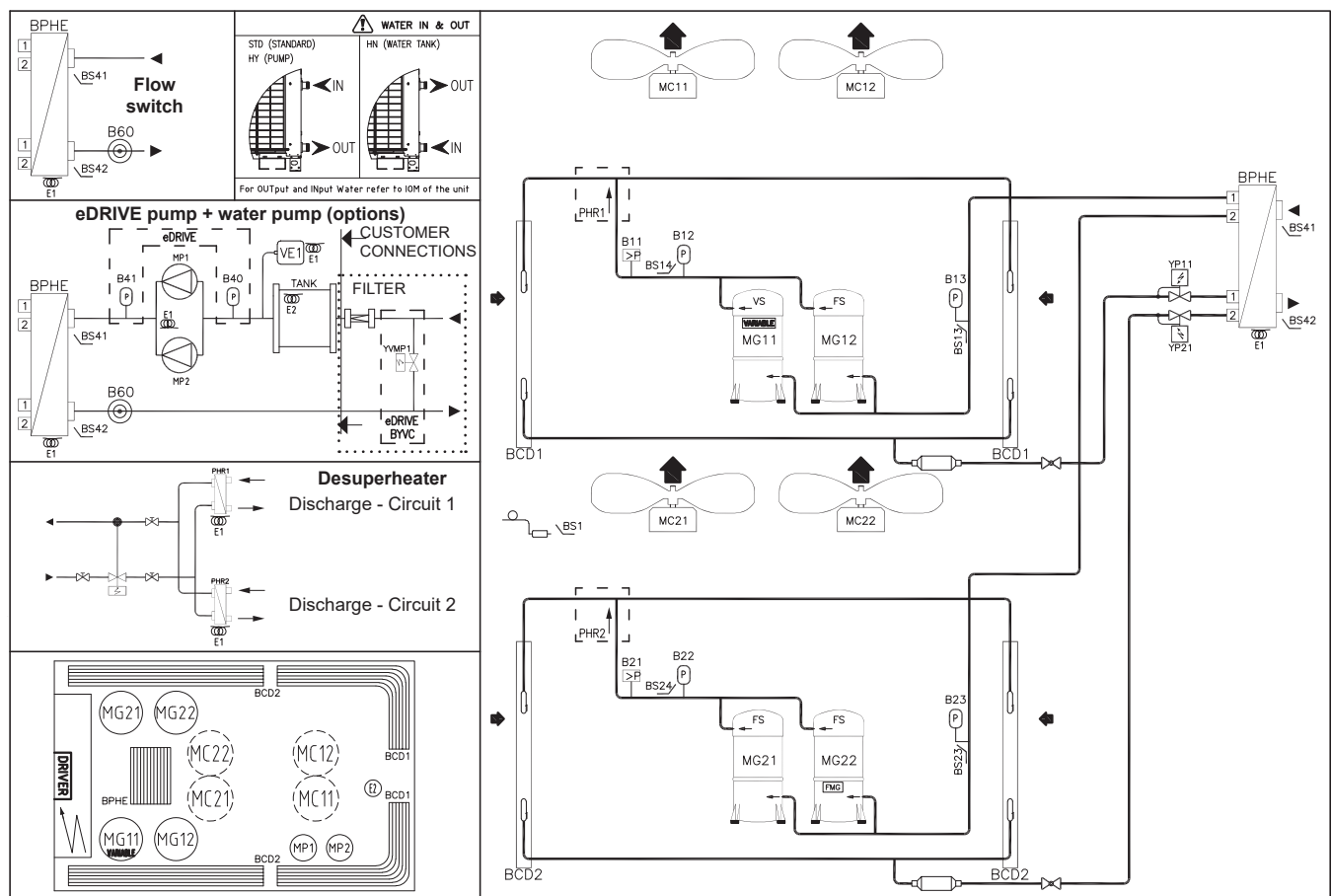

1.- GENERAL CHARACTERISTICS

1.7.- PIPING DRAWINGS COOLING ONLY UNITS

LEGEND		LEGEND	
B11	High pressure pressostat 1	BS41	Inlet water temperature
B12	High pressure transducer 1	BS42	Outlet water temperature
B13	Low pressure transducer 1	E1	Evaporator antifreeze heater
B21	High pressure pressostat 2	E2	Antifreeze heater
B22	High pressure transducer 2	E3-4-5-6	Electrical heater
B23	Low pressure transducer 2	LR	Liquid receiver
B40	Inlet water pressure	MC	Fan
B41	Outlet water pressure	MG	Scroll compressor
B60	Water flow switch	MP	Water Pump
BCD	Condenser	PHR 1-2	Partial Heat Recovery
BPHE	Evaporator (plate heat exchanger)	SLHE	Suction liquid heat exchanger
BS1	Outdoor temperature	VE1	Expansion vessel
BS13	Suction temperature 1	YP11	Electronic expansion valve - Circuit 1
BS14	Discharge temperature 1	YP21	Electronic expansion valve - Circuit 2
BS23	Suction temperature 2	YV12-22	4 way reversing valve
BS24	Discharge temperature 2	YVMP1	By-pass valve
FS	Fixed speed compressor	VS	Variable speed compressor



WARNING:
Check the inlet and outlet position of the water piping on the dimension drawings.
See indications on unit.



WARNING:
Consider that the inlet and outlet connections of the water piping can be different in the basic and advanced units.

1.- GENERAL CHARACTERISTICS

1.7.- PIPING DRAWINGS

BASIC UNITS - HEAT PUMP UNITS

GAH B-BOX 035S-040S-045S

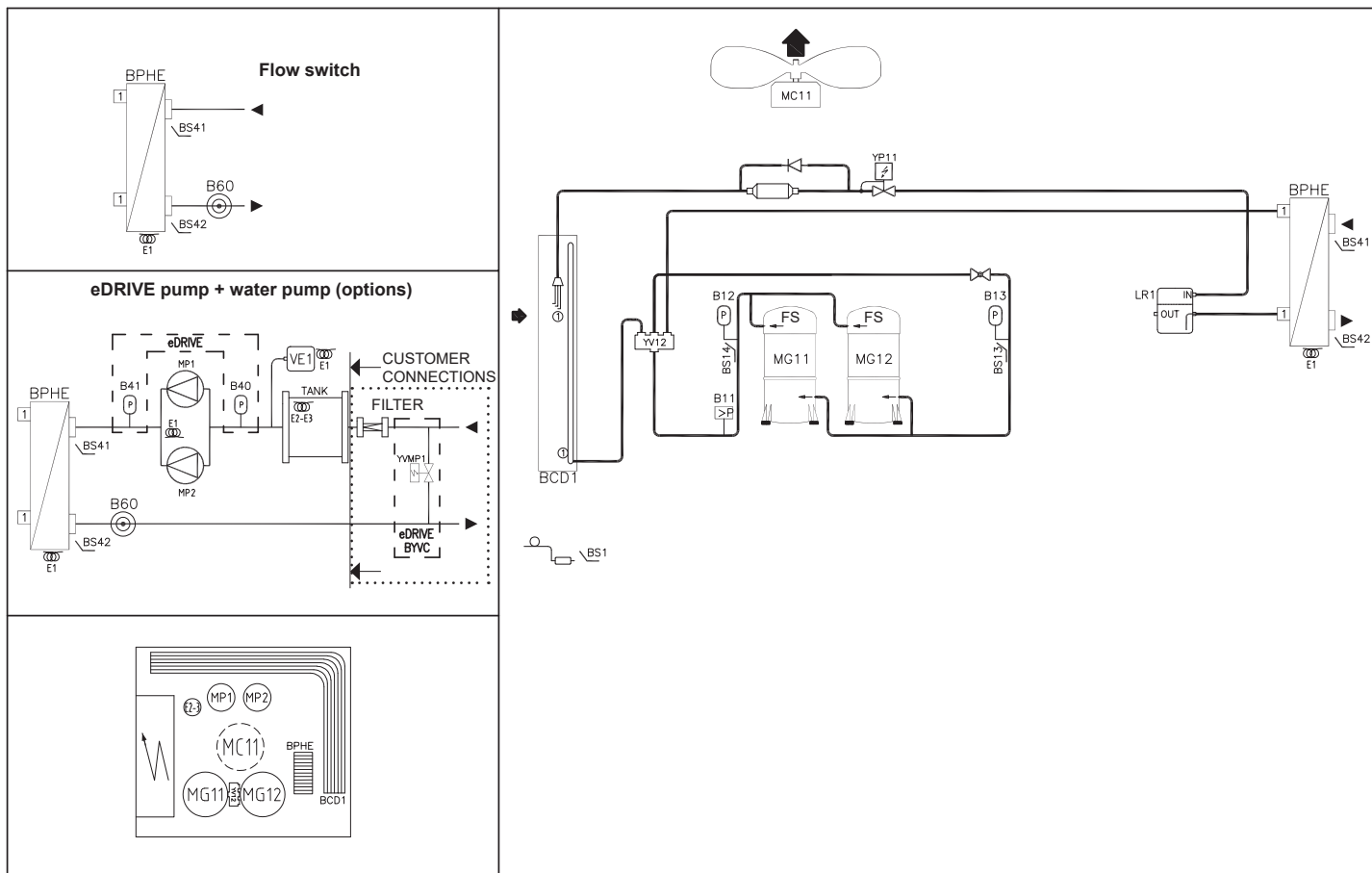

GAH B+BOX 050S-055S-060S

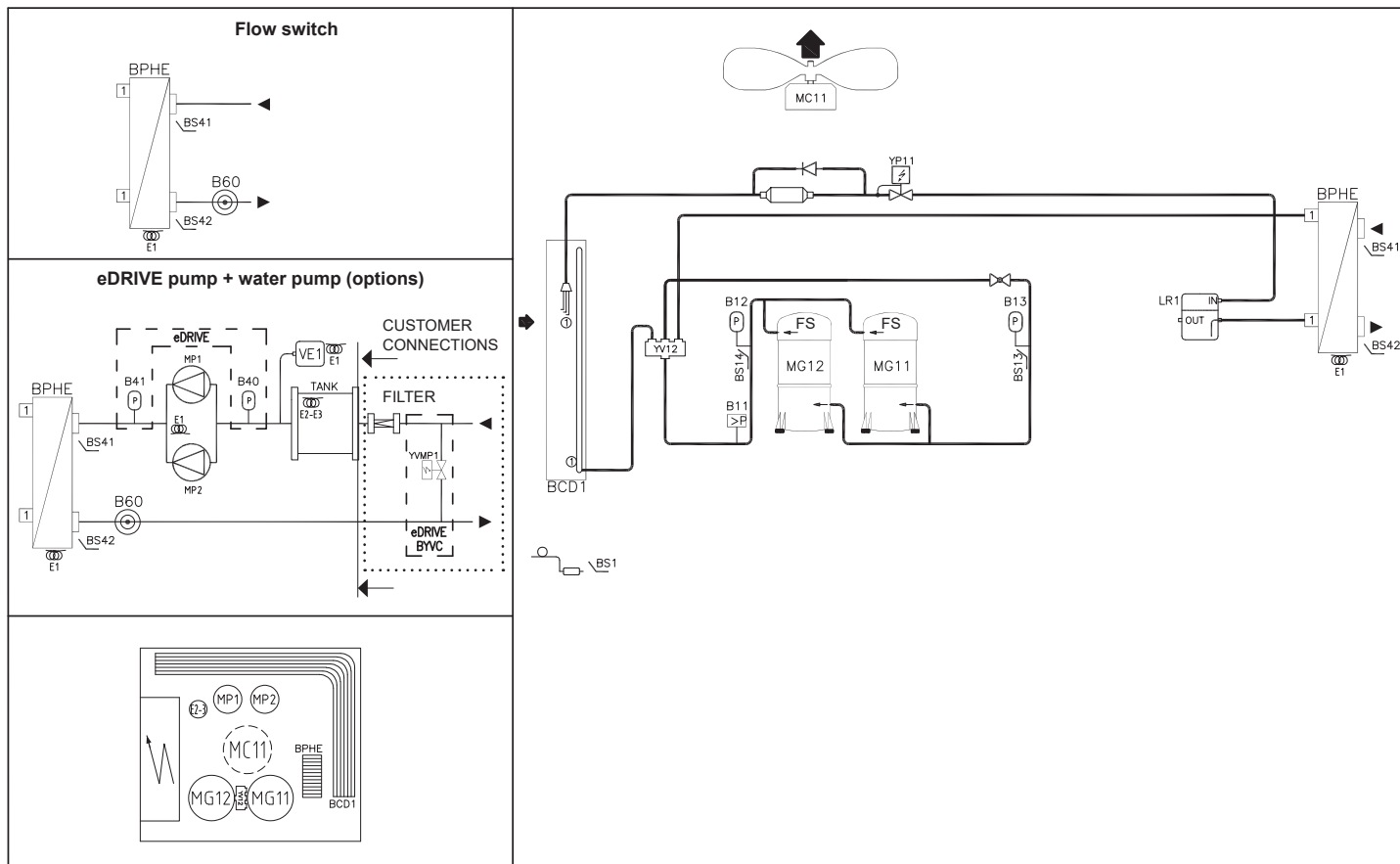

1.- GENERAL CHARACTERISTICS

1.7.- PIPING DRAWINGS

BASIC UNITS - HEAT PUMP UNITS

GAH C-BOX 065S-070S-080S

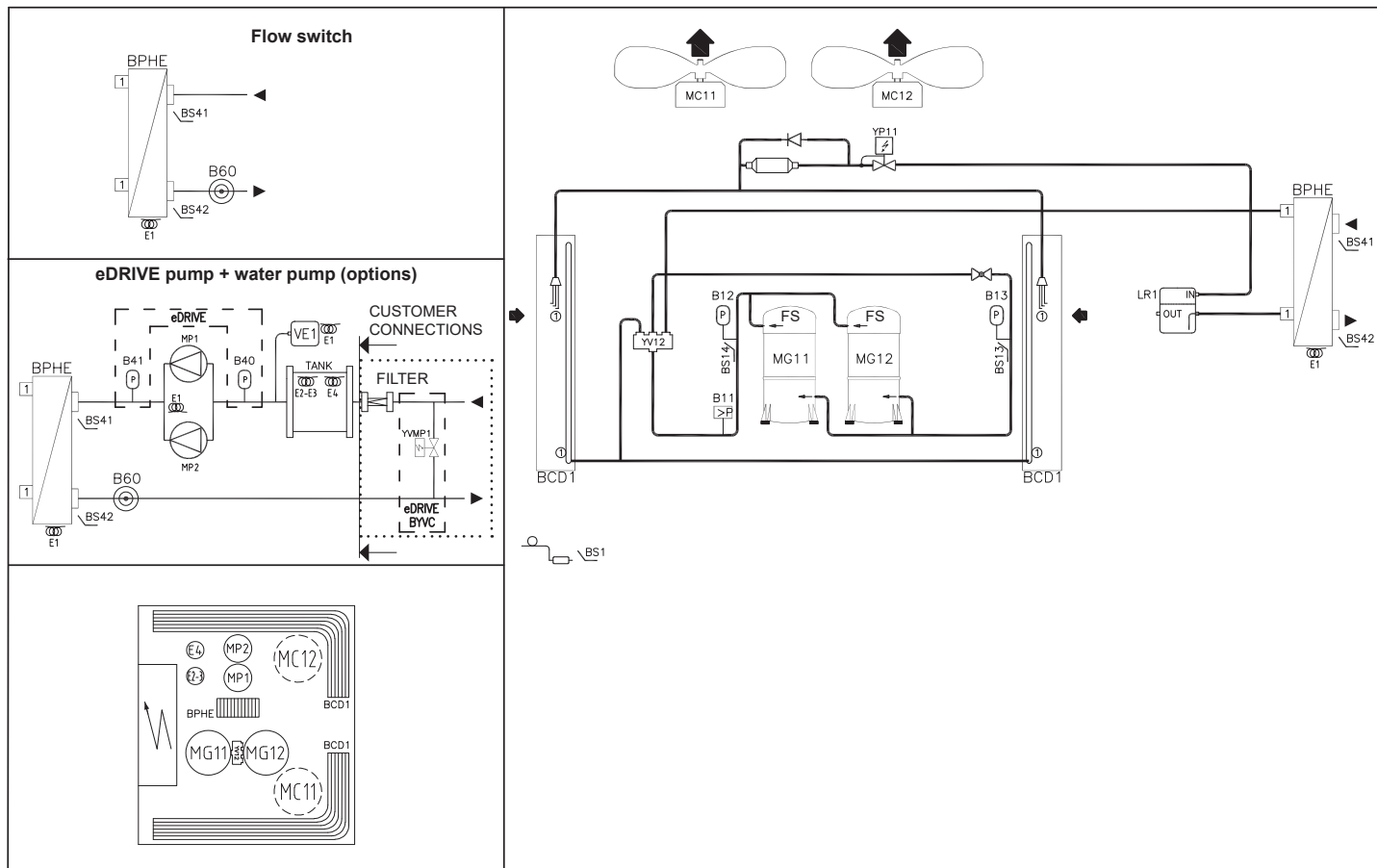

GAH C+BOX 095S-110S

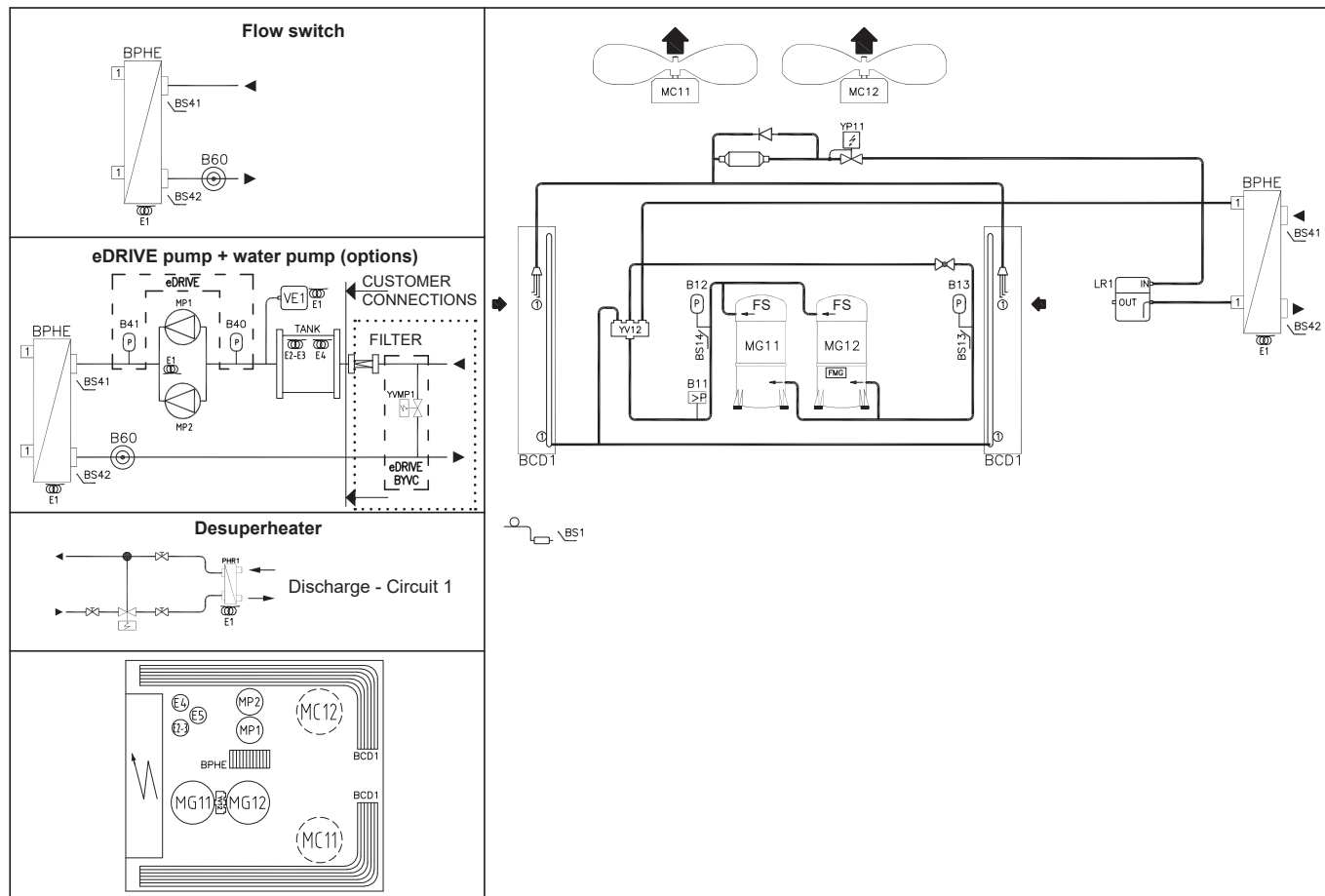

1.- GENERAL CHARACTERISTICS

1.7.- PIPING DRAWINGS

BASIC UNITS - HEAT PUMP UNITS

GAH C+ - BOX 115S

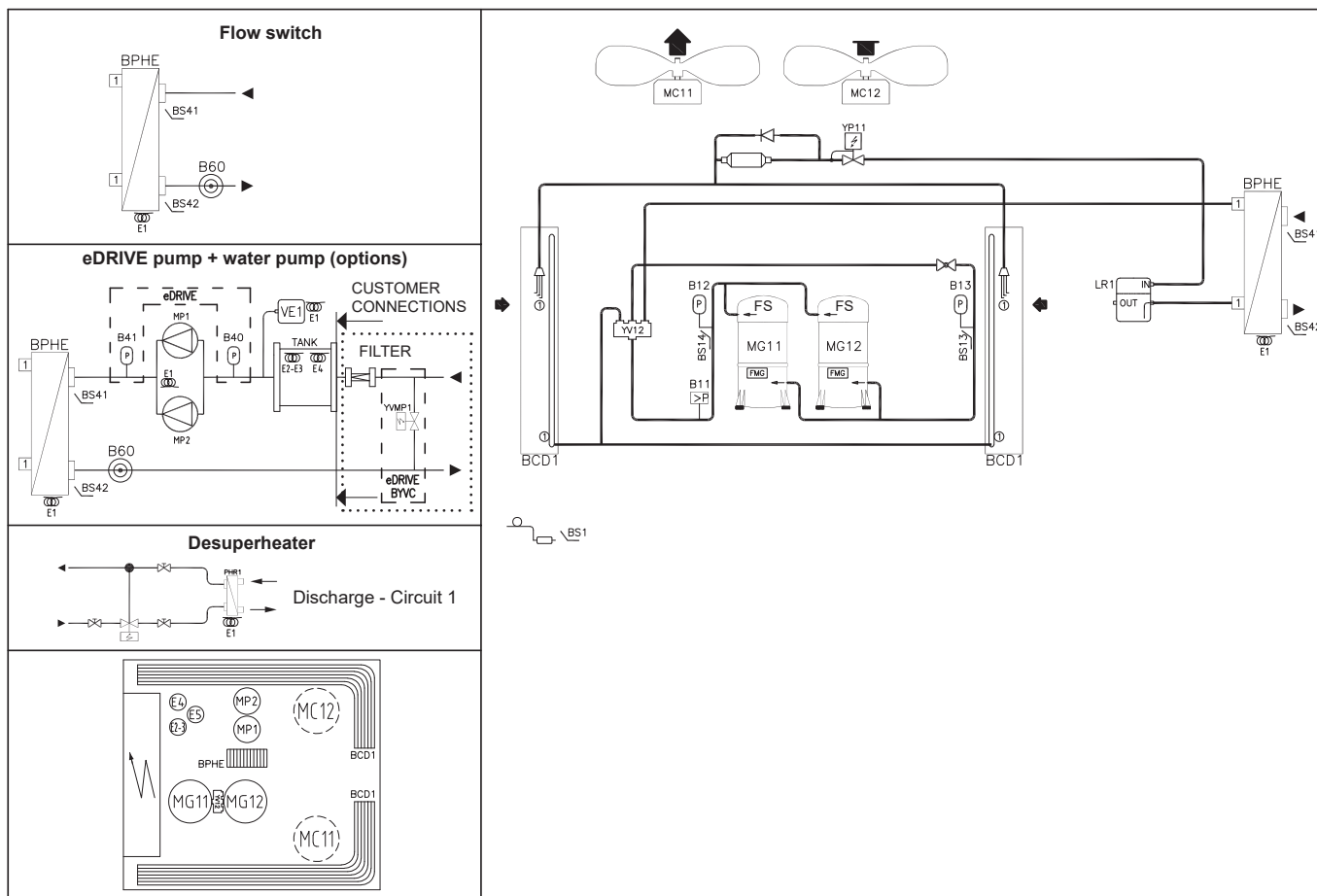

GAH D - BOX 125S

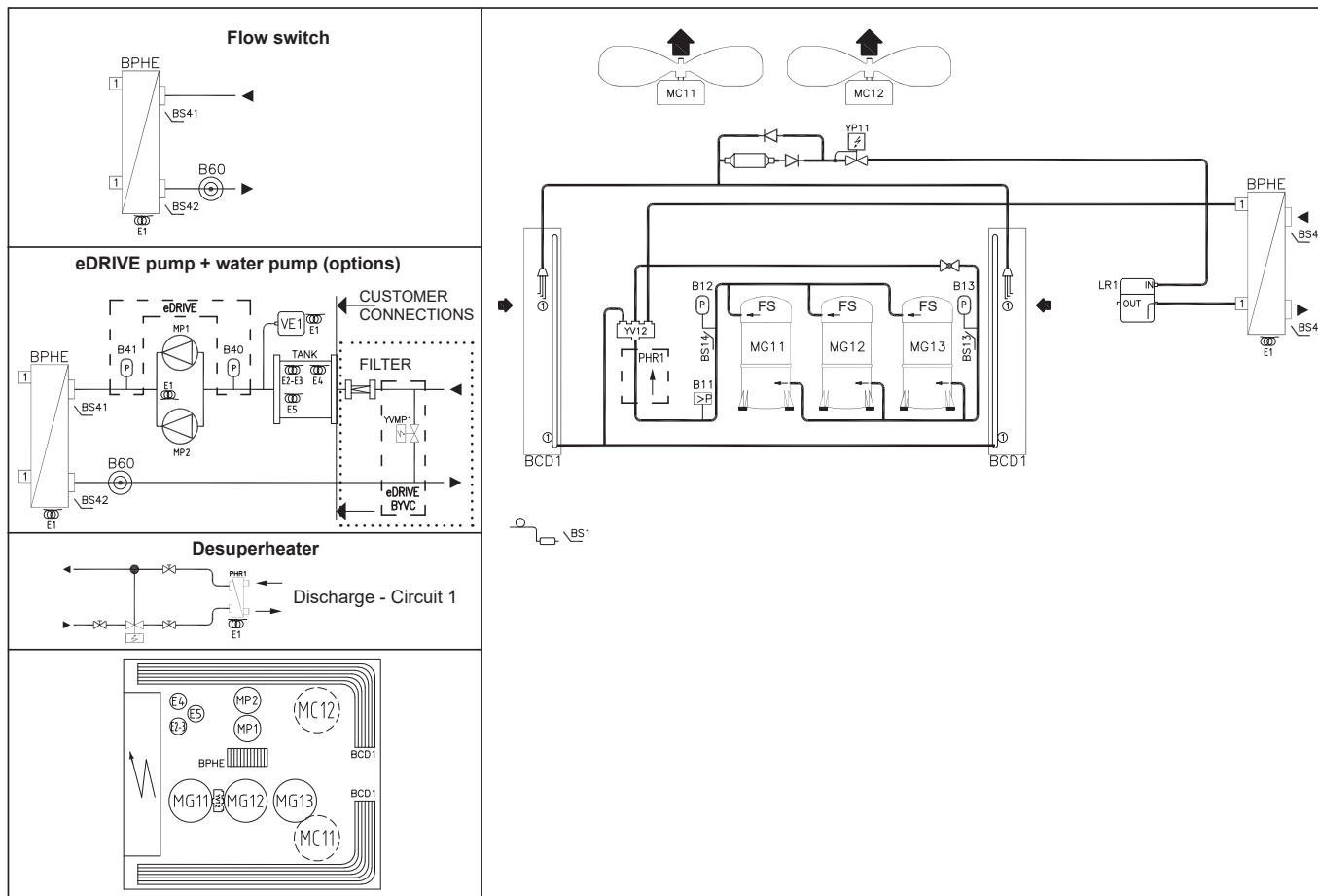

1.- GENERAL CHARACTERISTICS

1.7.- PIPING DRAWINGS

BASIC UNITS - HEAT PUMP UNITS

GAH D-BOX 140S

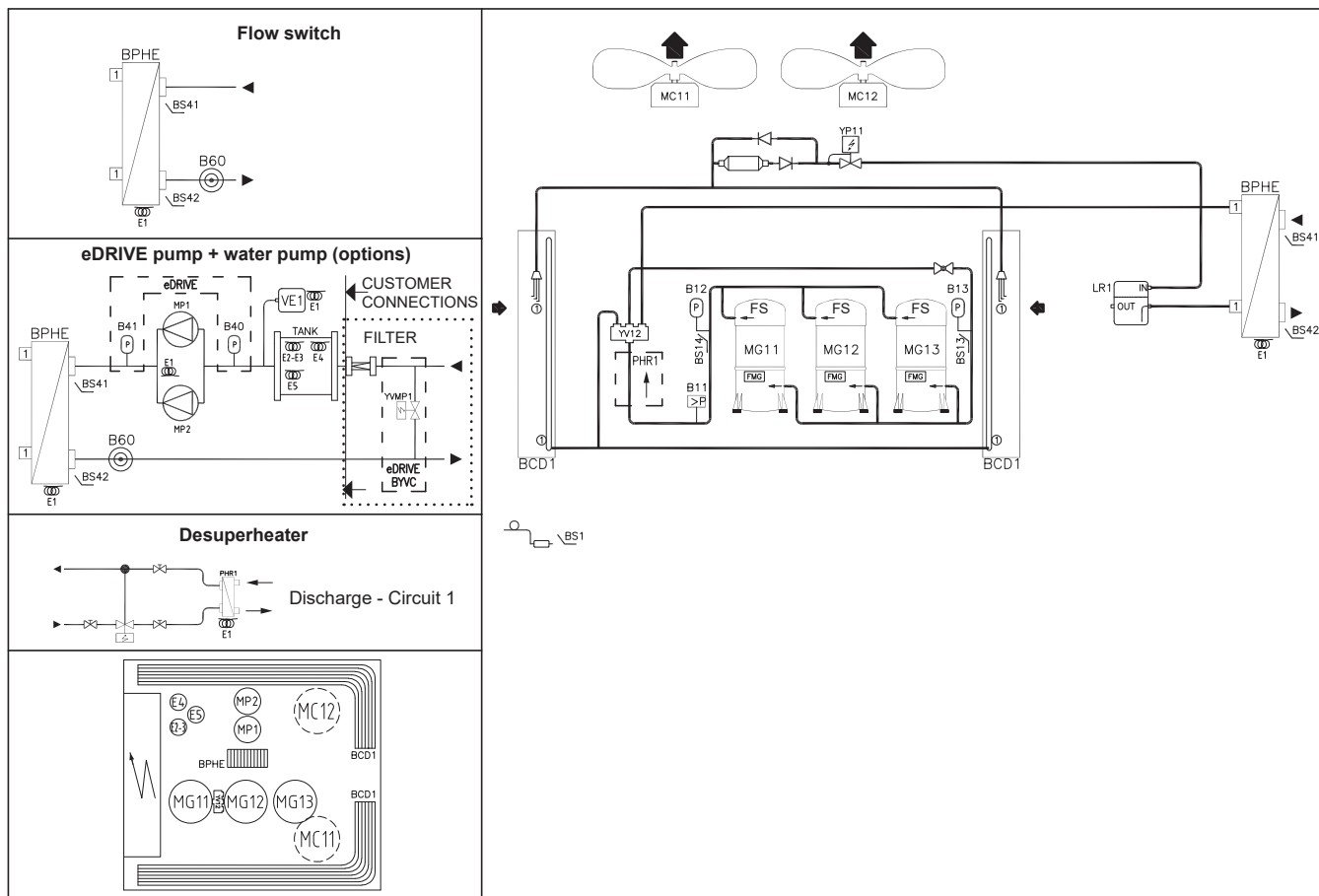

GAH D-BOX 110D-125D-140D

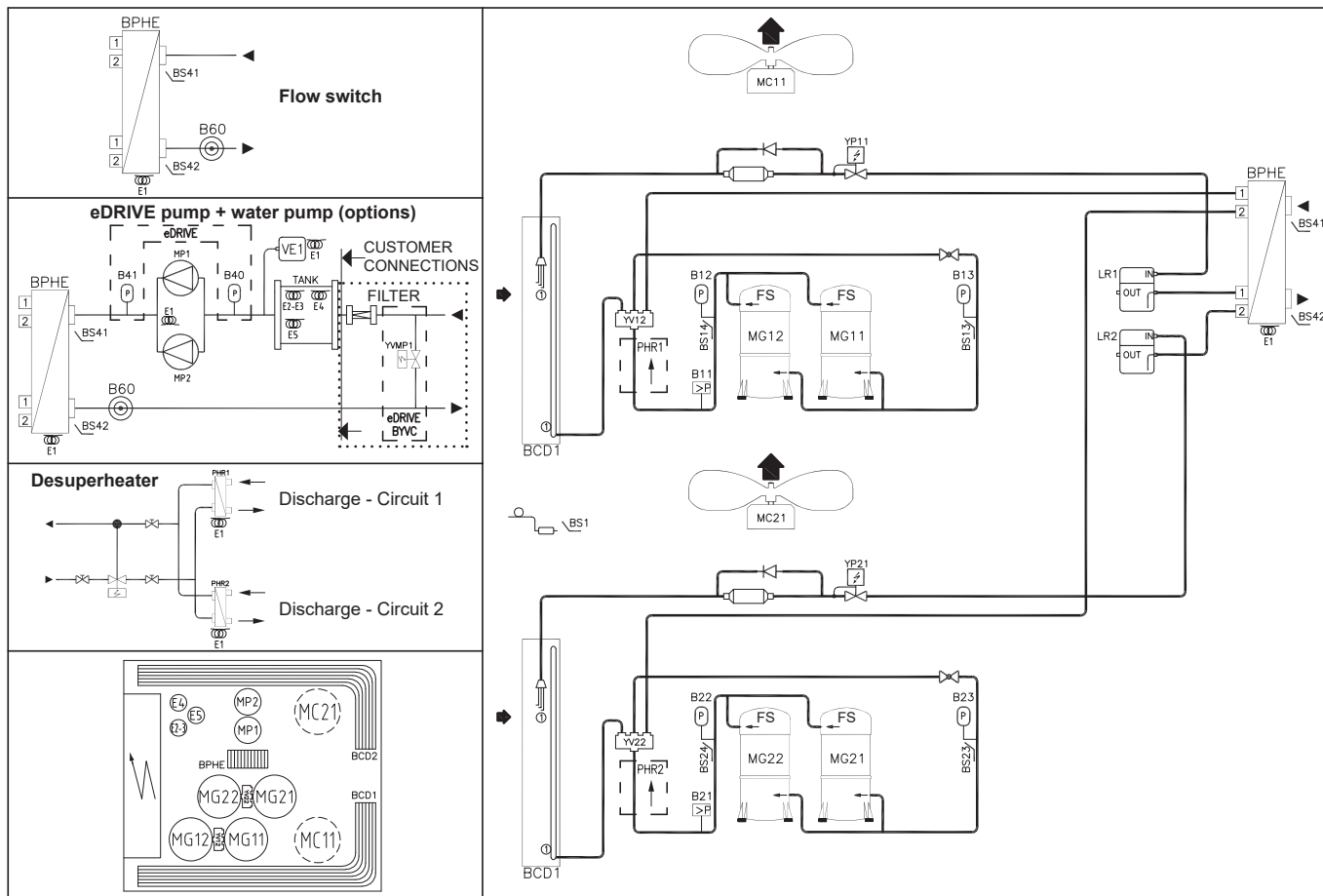

1.- GENERAL CHARACTERISTICS

1.7.- PIPING DRAWINGS

BASIC UNITS - HEAT PUMP UNITS

GAH E-BOX 160D

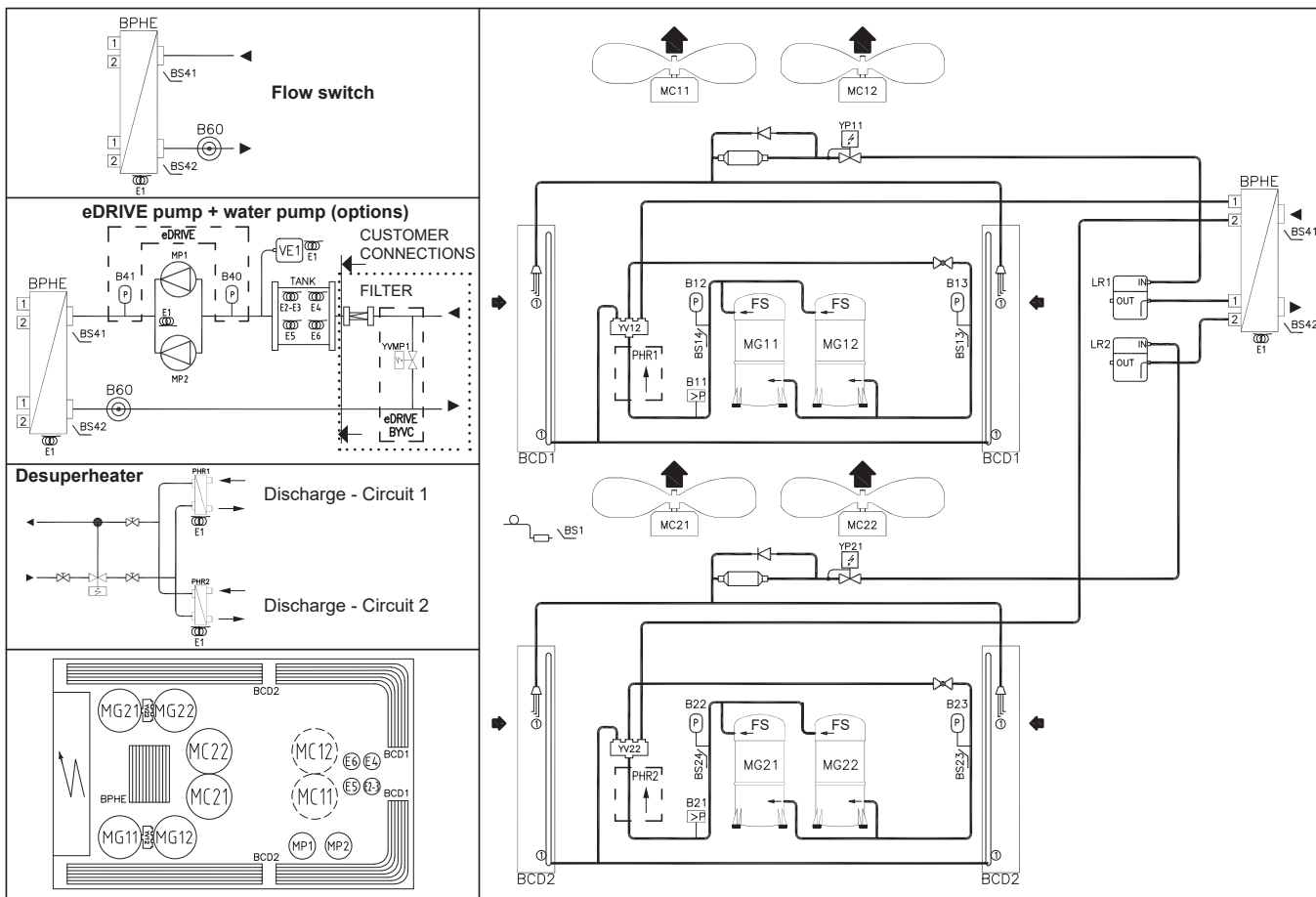

GAH E-BOX 185D-210D

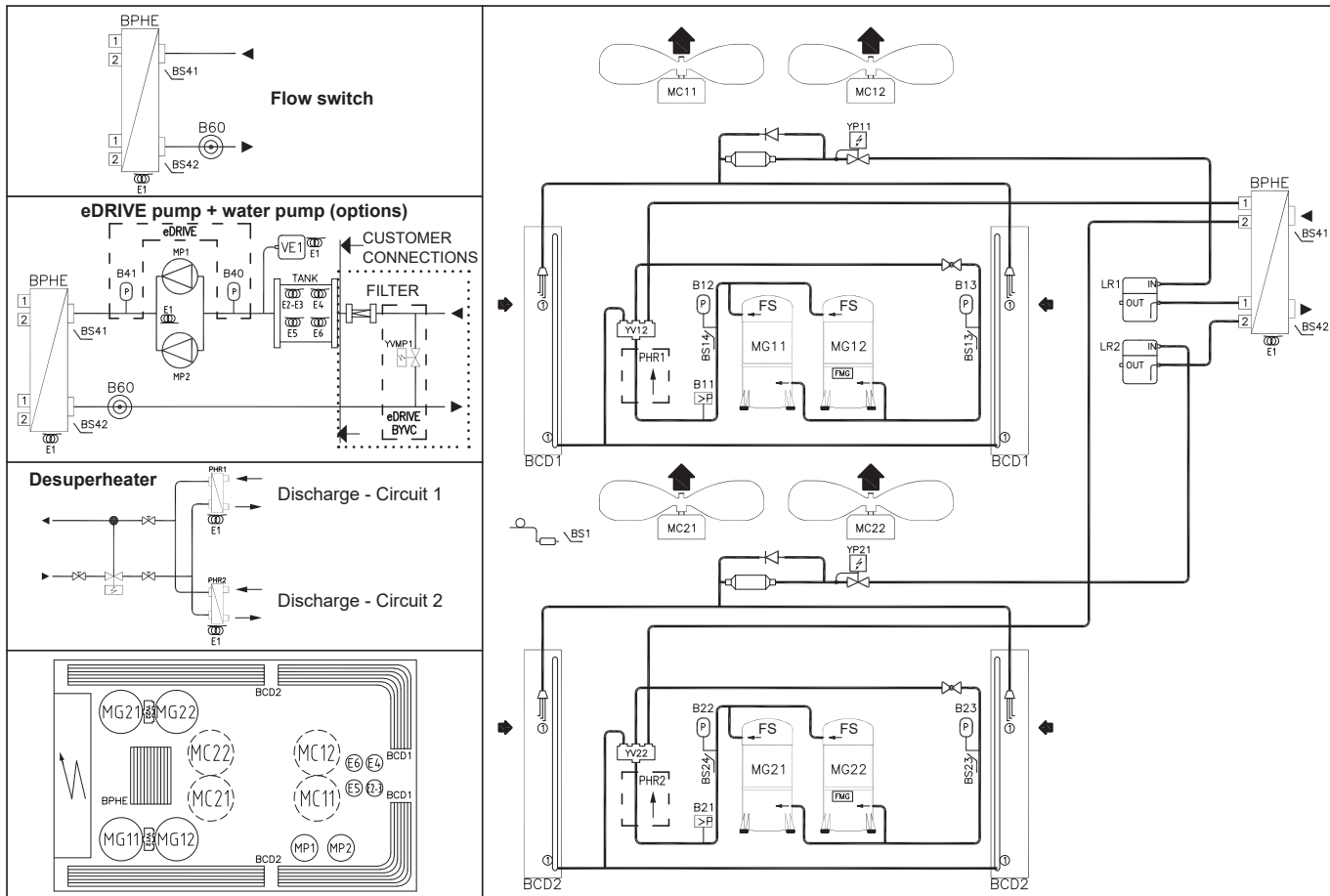

1.- GENERAL CHARACTERISTICS

1.7.- PIPING DRAWINGS ADVANCED UNITS - HEAT PUMP UNITS

GBH B-BOX 040S

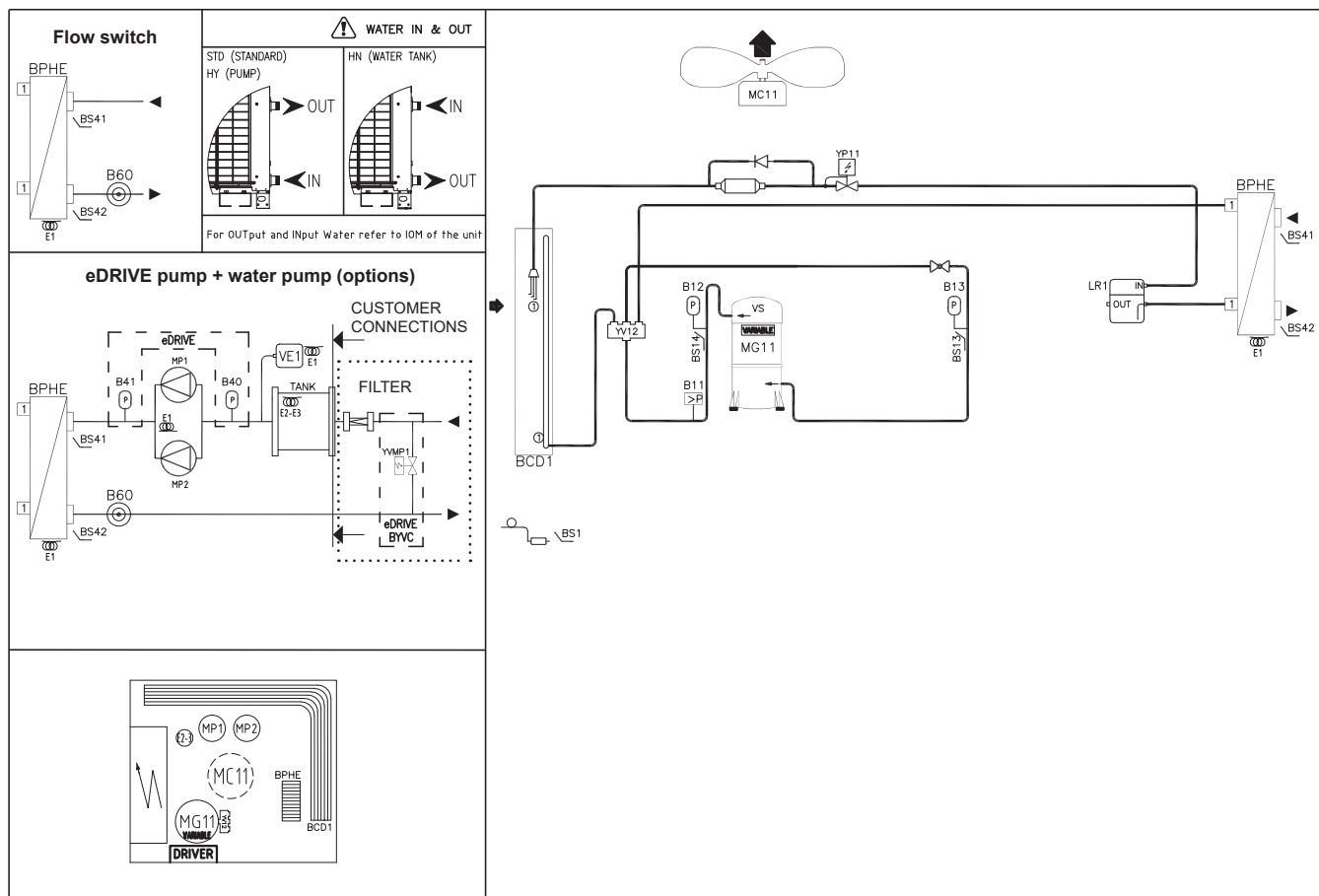

GBH B+-BOX 060S

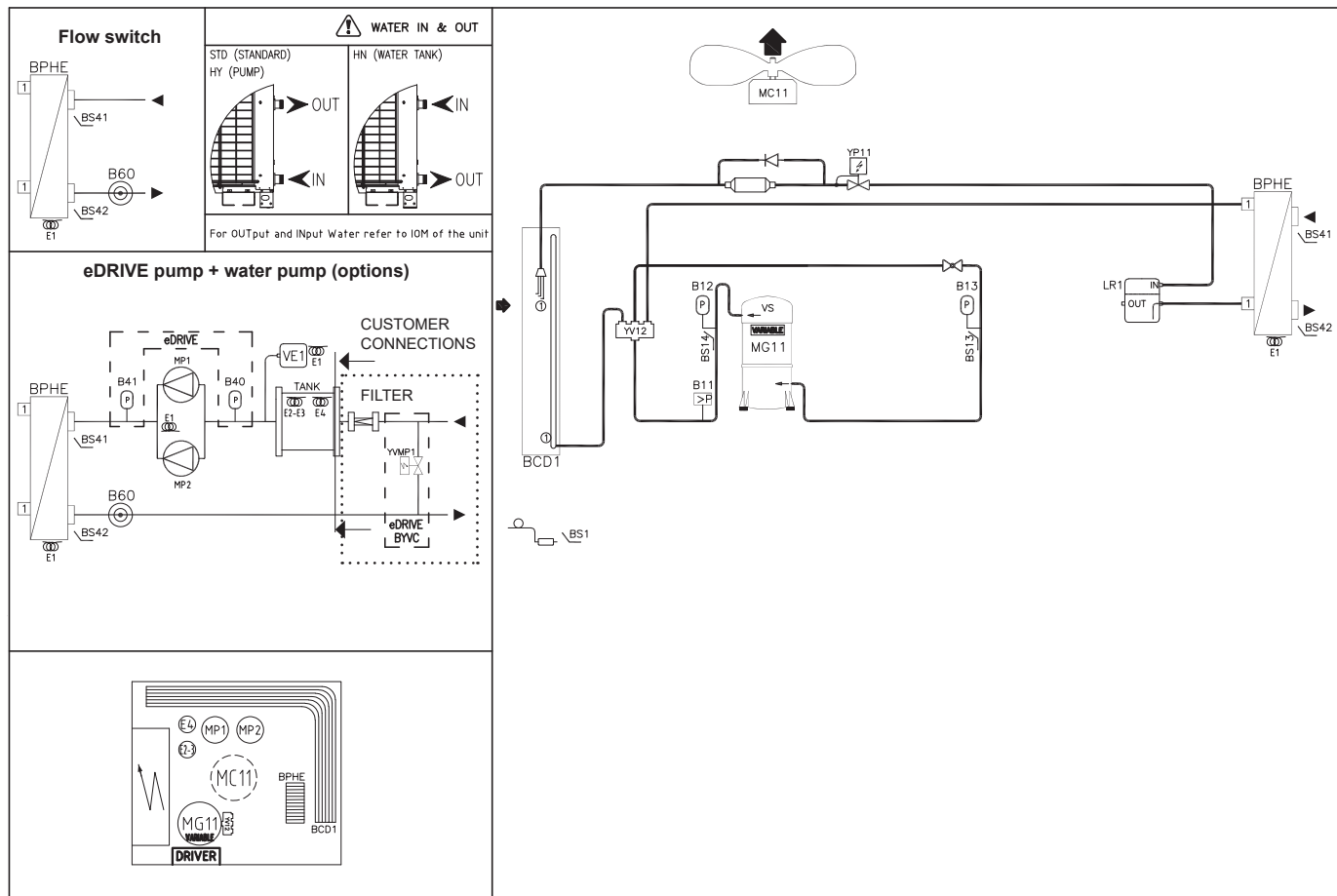

1.- GENERAL CHARACTERISTICS

1.7.- PIPING DRAWINGS
ADVANCED UNITS - HEAT PUMP UNITS

GBH C-BOX 070S-080S

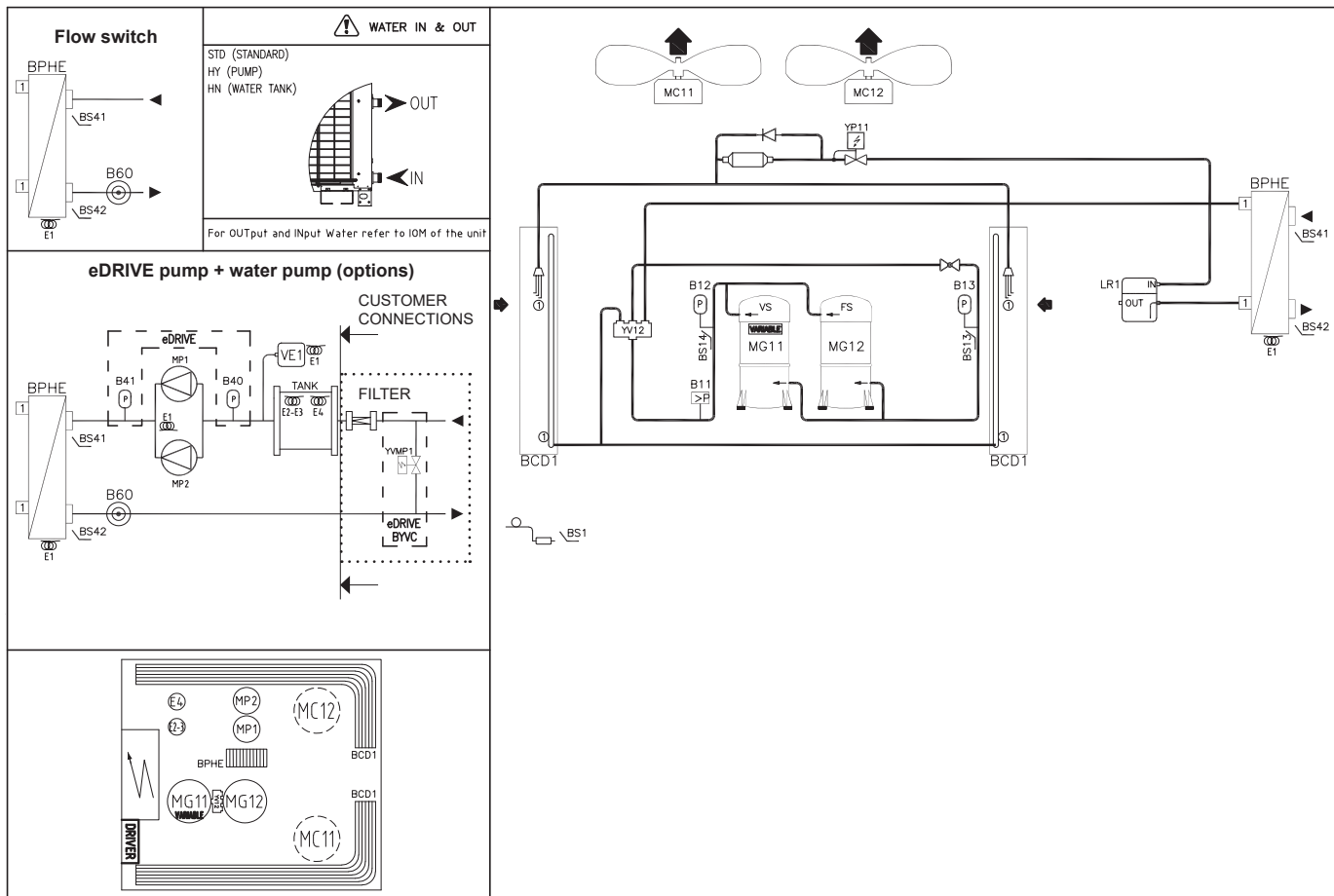

GBH C+BOX 110S

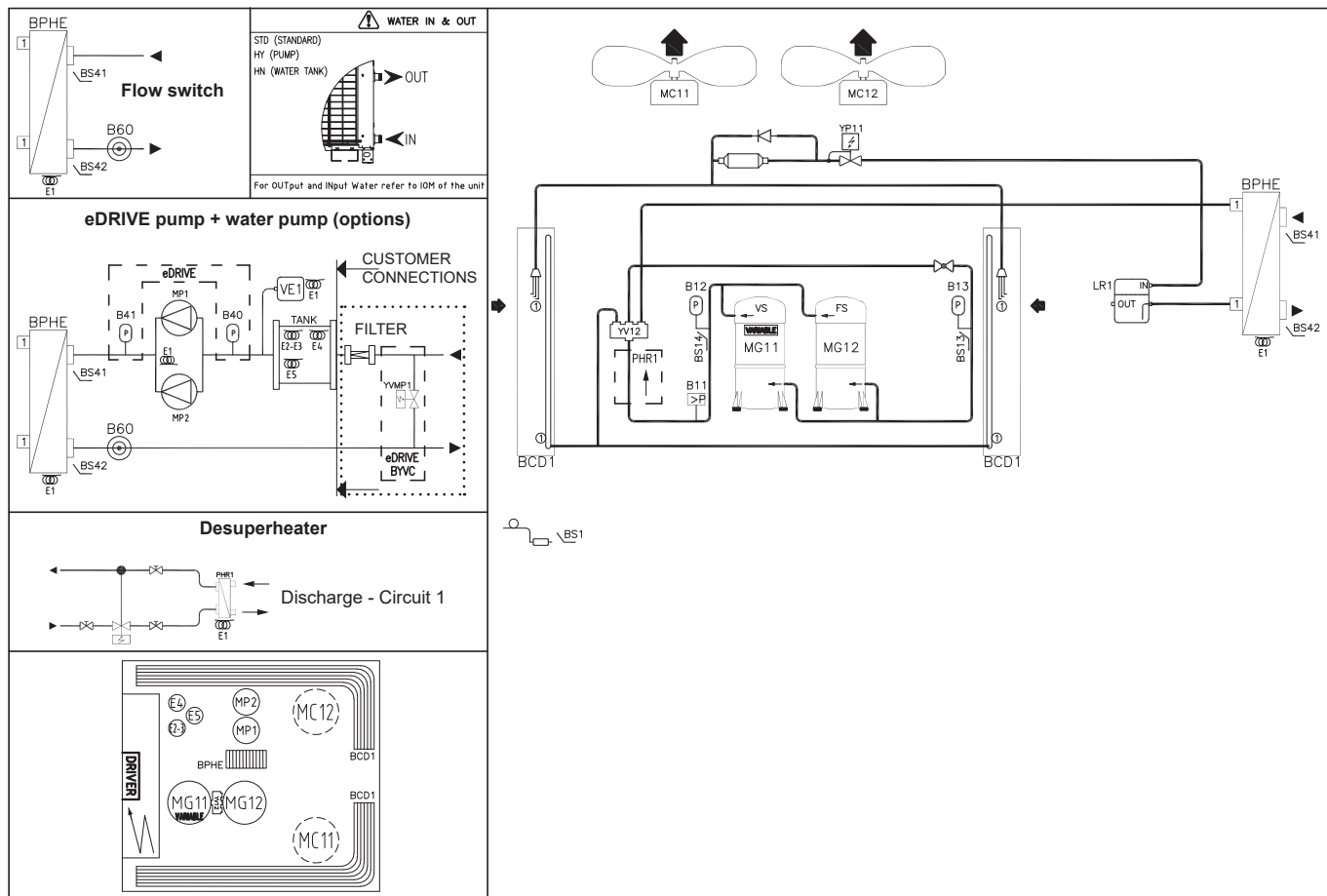

1.- GENERAL CHARACTERISTICS

1.7.- PIPING DRAWINGS

ADVANCED UNITS - HEAT PUMP UNITS

GBH C+-BOX 120S

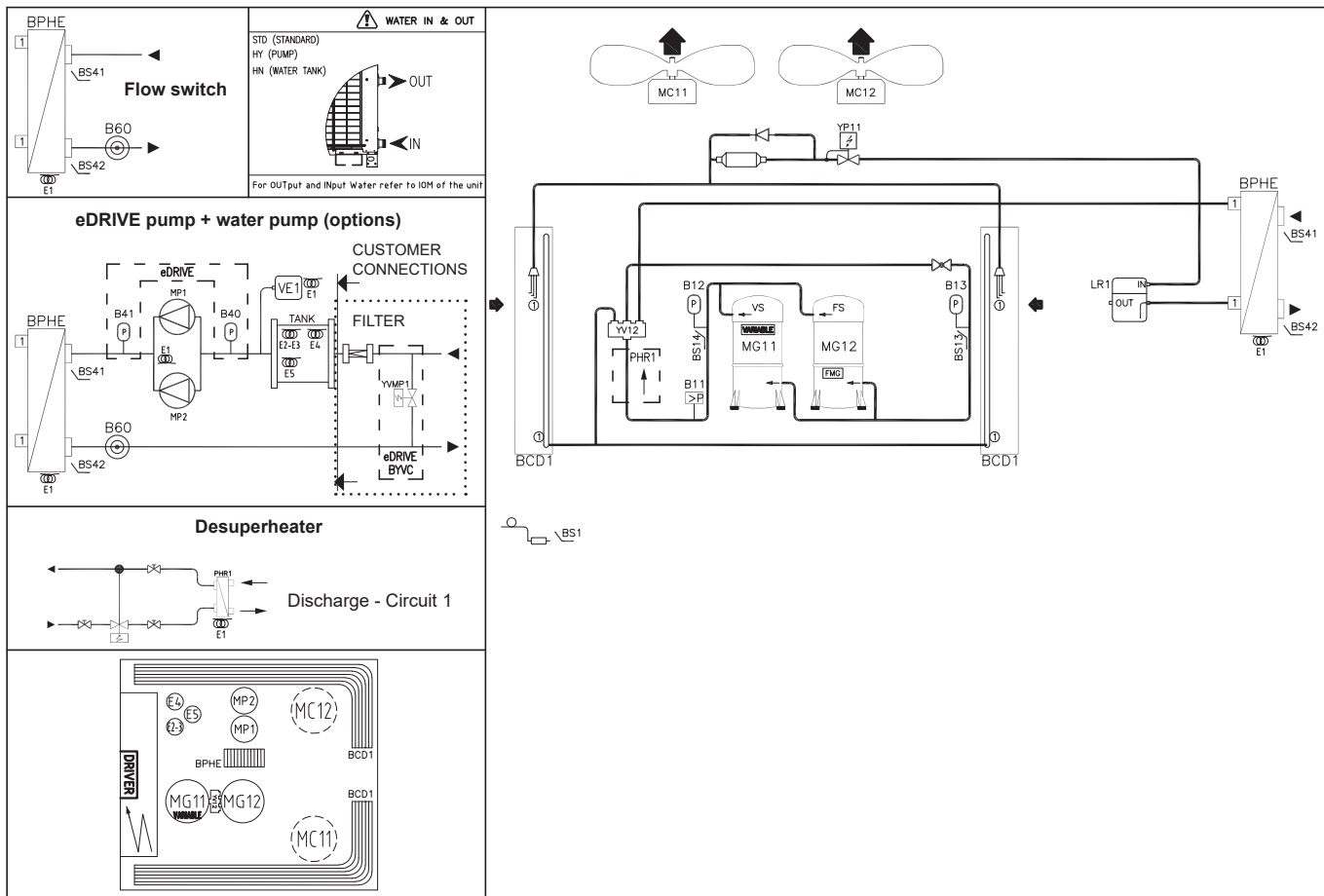

GBH D-BOX 125D-140D

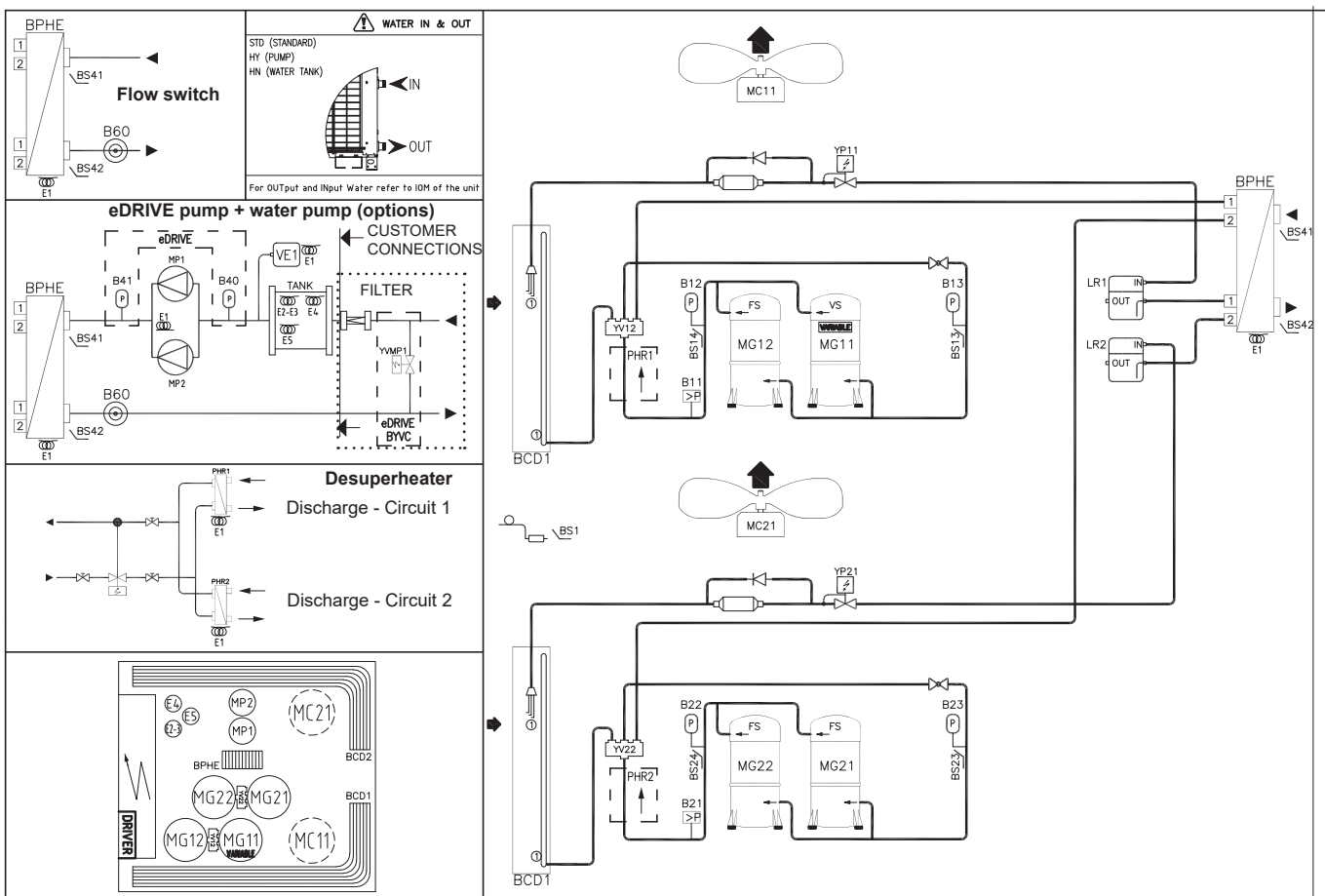

1.- GENERAL CHARACTERISTICS

1.7.- PIPING DRAWINGS
ADVANCED UNITS - HEAT PUMP UNITS

GBH E-BOX 160D

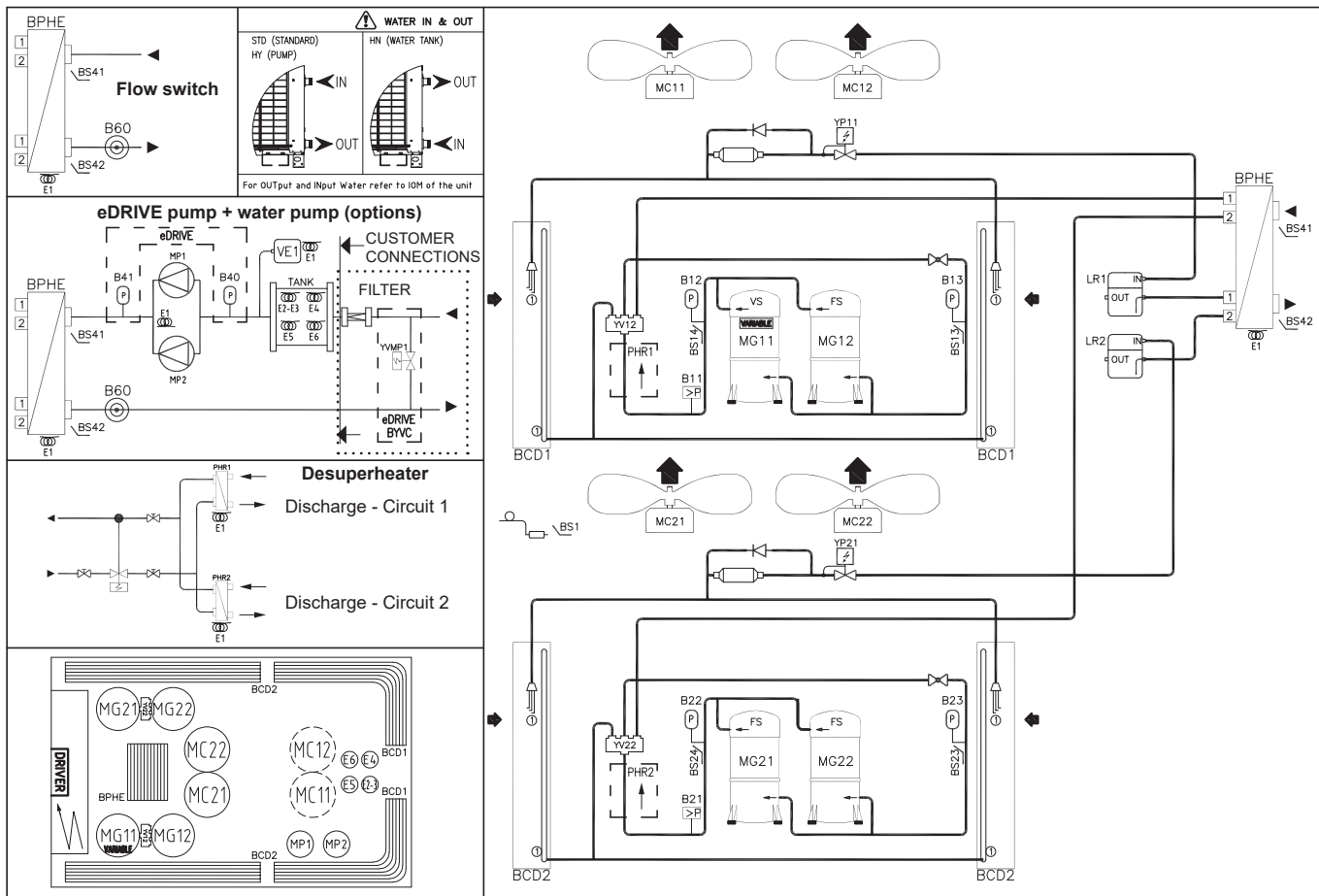

GBH E-BOX 185D-210D

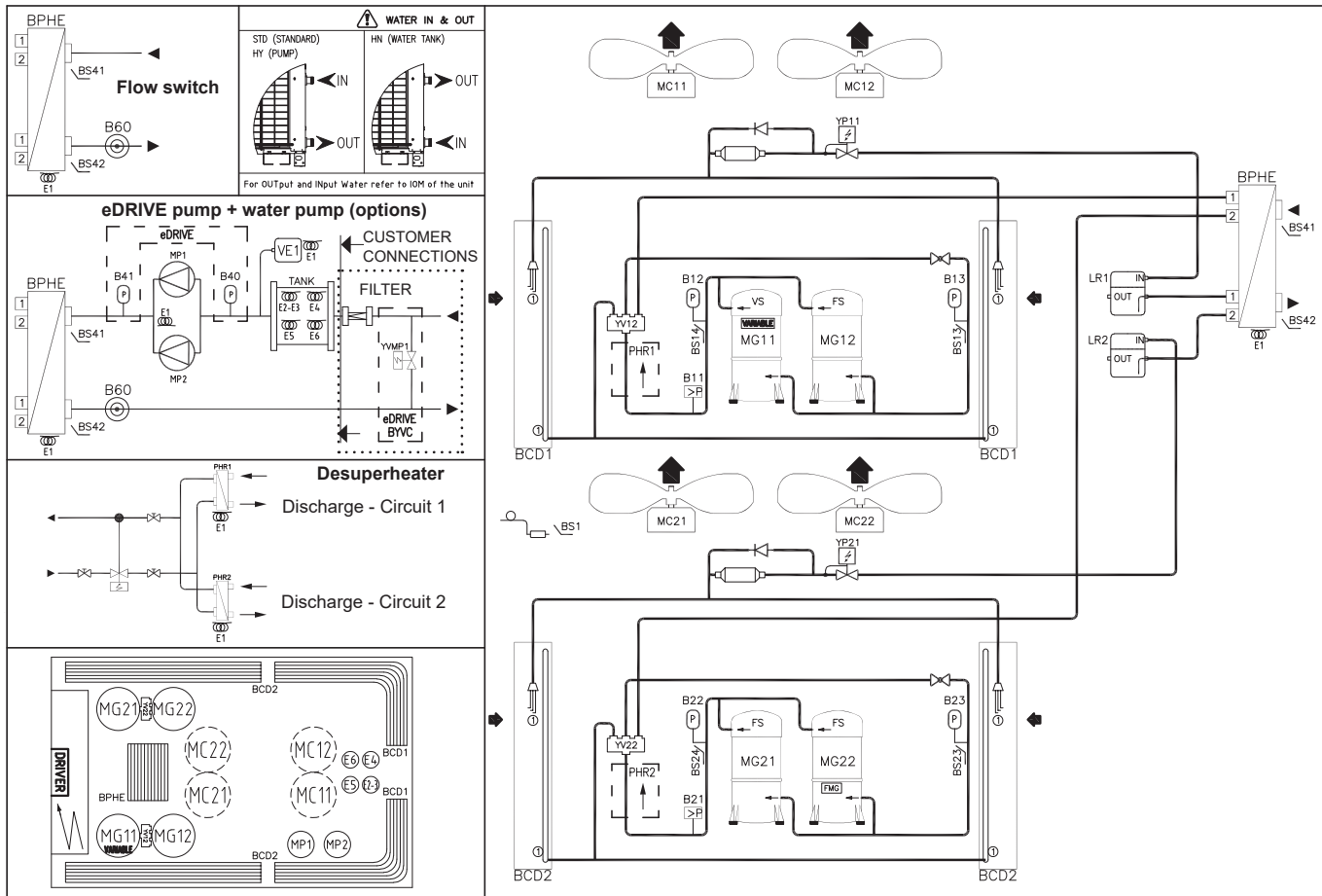

1.- GENERAL CHARACTERISTICS

1.7.- PIPING DRAWINGS HEAT PUMP UNITS

LEGEND		LEGEND	
B11	High pressure pressostat 1	BS41	Inlet water temperature
B12	High pressure transducer 1	BS42	Outlet water temperature
B13	Low pressure transducer 1	E1	Evaporator antifreeze heater
B21	High pressure pressostat 2	E2	Antifreeze heater
B22	High pressure transducer 2	E3-4-5-6	Electrical heater
B23	Low pressure transducer 2	LR	Liquid receiver
B40	Inlet water pressure	MC	Fan
B41	Outlet water pressure	MG	Scroll compressor
B60	Water flow switch	MP	Water Pump
BCD	Condenser	PHR 1-2	Partial Heat Recovery
BPHE	Evaporator (plate heat exchanger)	SLHE	Suction liquid heat exchanger
BS1	Outdoor temperature	VE1	Expansion vessel
BS13	Suction temperature 1	YP11	Electronic expansion valve - Circuit 1
BS14	Discharge temperature 1	YP21	Electronic expansion valve - Circuit 2
BS23	Suction temperature 2	YV12-22	4 way reversing valve
BS24	Discharge temperature 2	YVMP1	By-pass valve
FS	Fixed speed compressor	VS	Variable speed compressor



WARNING:

Check the inlet and outlet position of the water piping on the dimension drawings.
See indications on unit.



WARNING:

Consider that the inlet and outlet connections of the water piping can be different in the basic and advanced units.

1.- GENERAL CHARACTERISTICS

1.8.- DIMENSIONS

GAC/H 035S

STANDARD VERSION OR WITH HIGH PRESSURE EC FANS (HIPF)

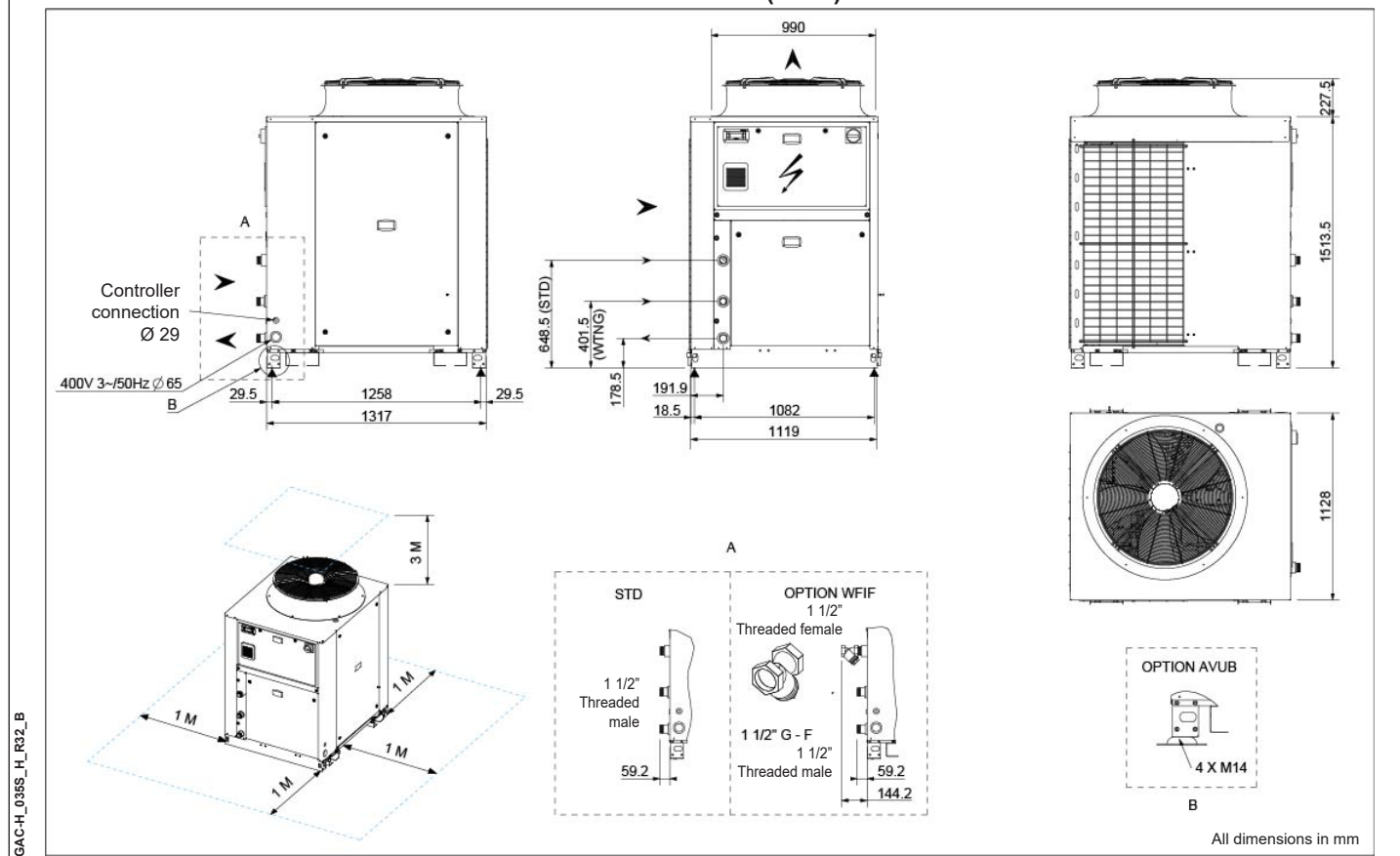

UNIT WITH OPTIONAL AC FANS (SFAC)

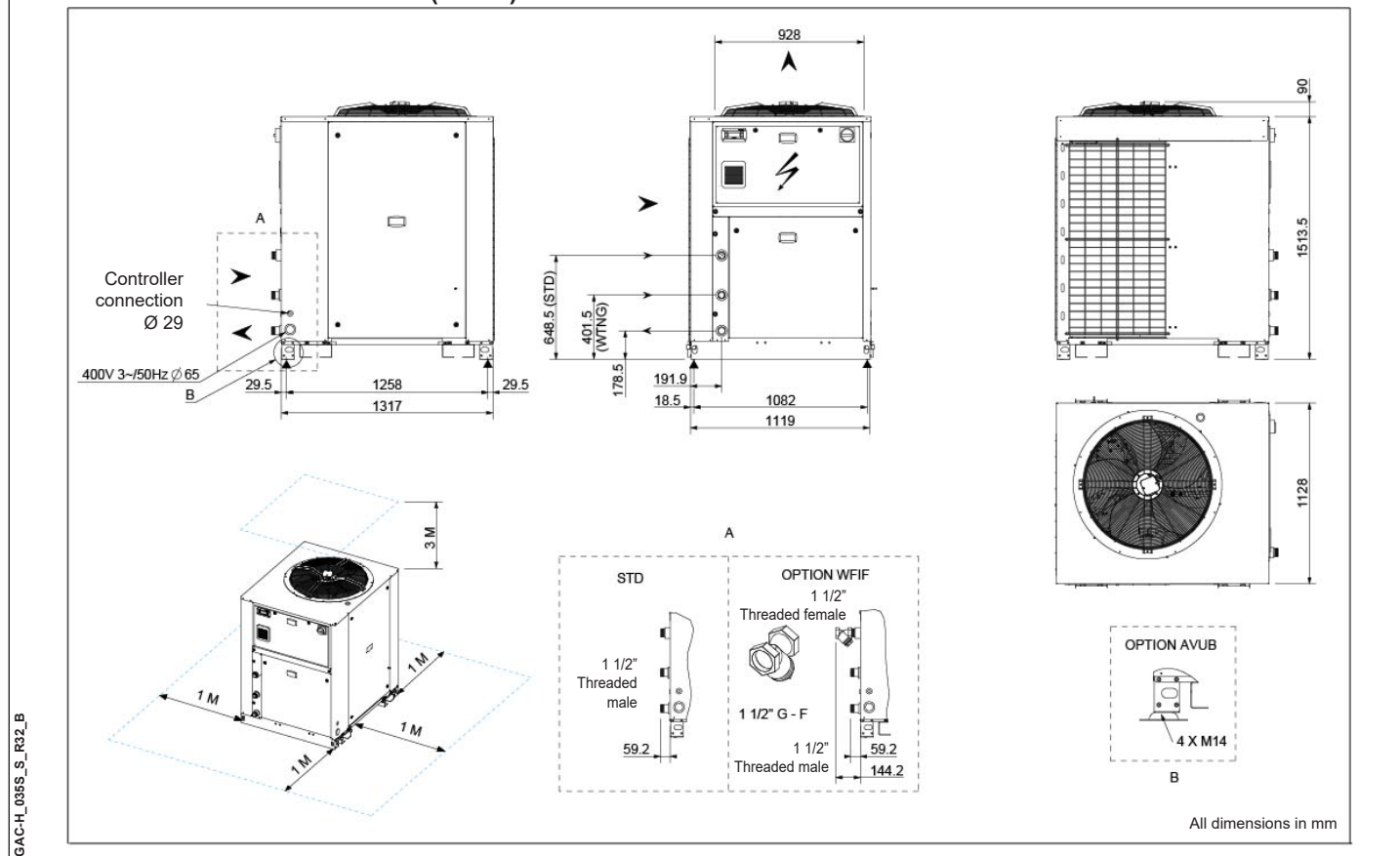

SPXX	Hydraulic module with single pump	WTNG	Water tank
DPXX	Hydraulic module with twin pump	WFIF	Water filter (supplied loose)
AVUB	Rubber anti-vibration mounts		

1.- GENERAL CHARACTERISTICS

1.8.- DIMENSIONS

GAC/H 040S-045S

STANDARD VERSION OR WITH HIGH PRESSURE EC FANS (HIPF)

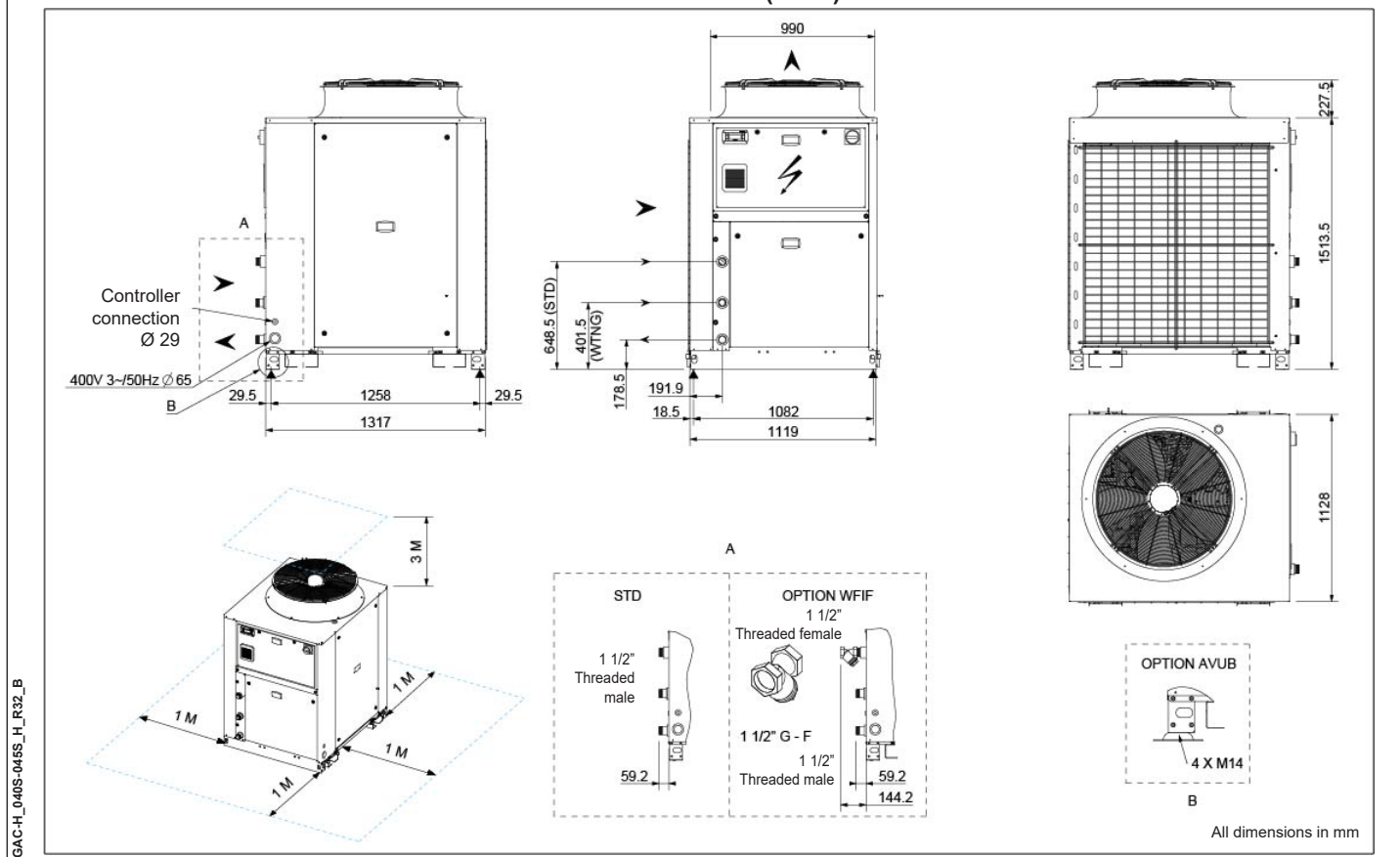

UNIT WITH OPTIONAL AC FANS (SFAC)

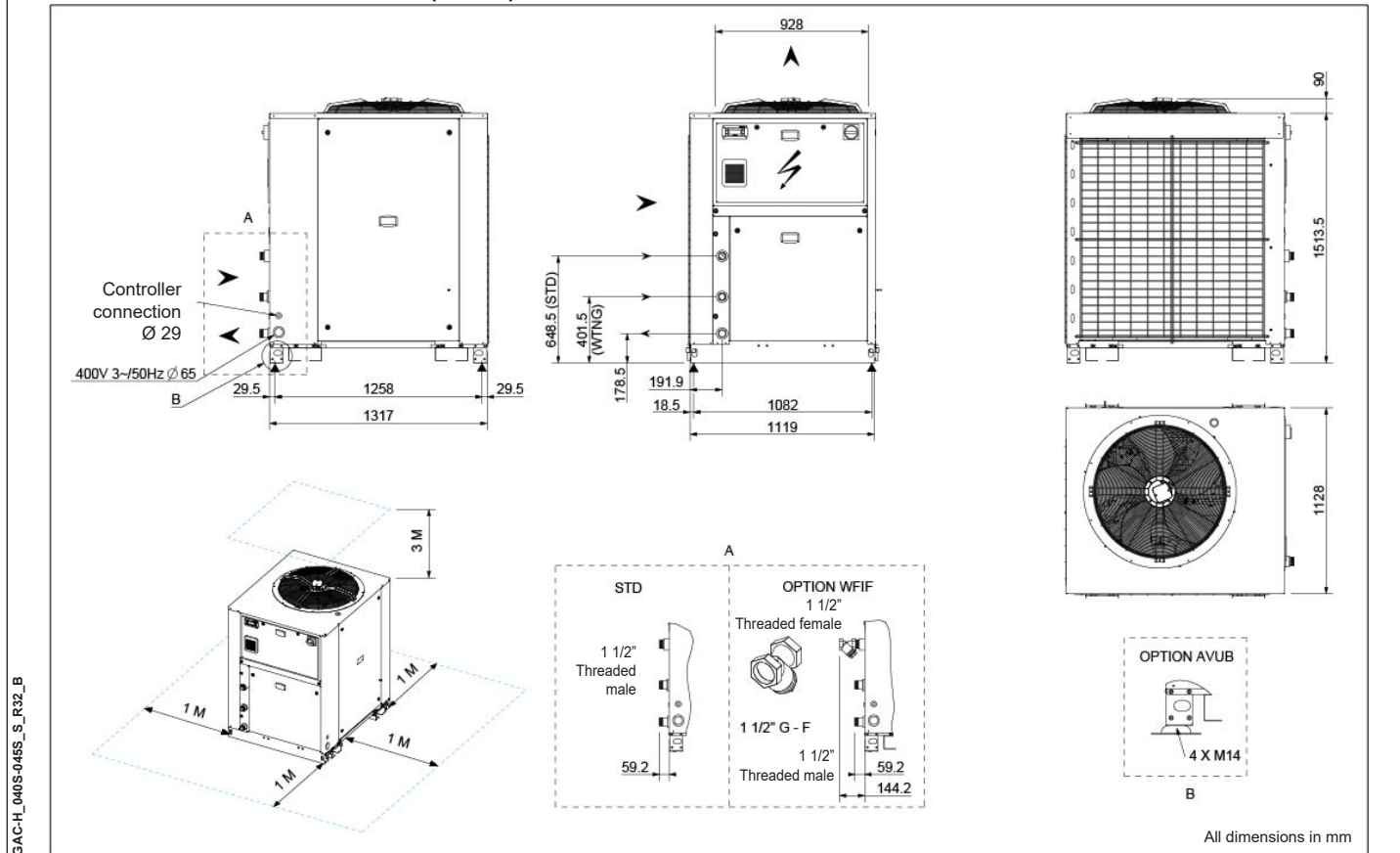

SPXX	Hydraulic module with single pump
DPXX	Hydraulic module with twin pump
AVUB	Rubber anti-vibration mounts

WTNG	Water tank
WFIF	Water filter (supplied loose)

1.- GENERAL CHARACTERISTICS

1.8.- DIMENSIONS

GAC/H 050S-055S-060S

STANDARD VERSION OR WITH HIGH PRESSURE EC FANS (HIPF)

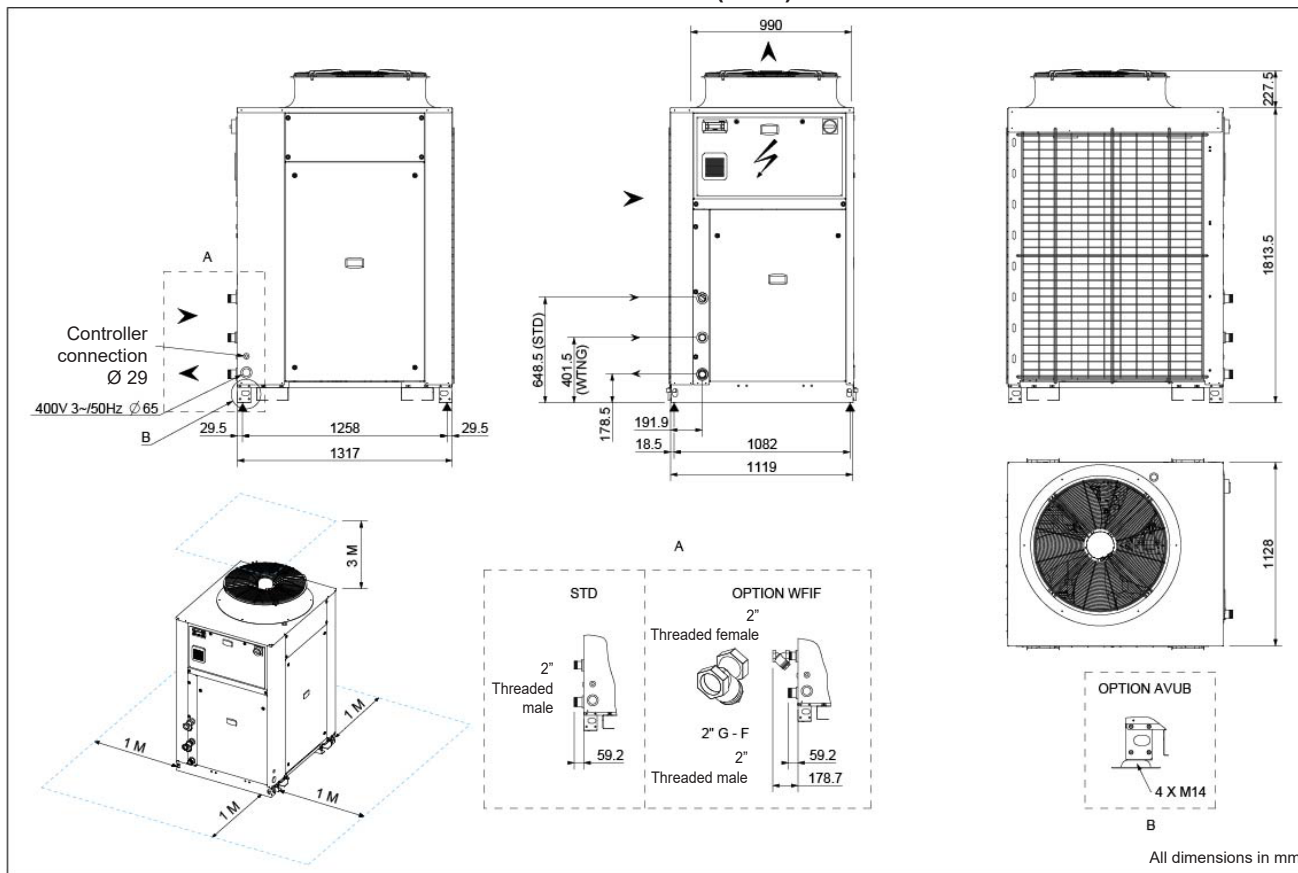

GAC-H_060S_055S_060S_H_R32_C

UNIT WITH OPTIONAL AC FANS (SFAC)

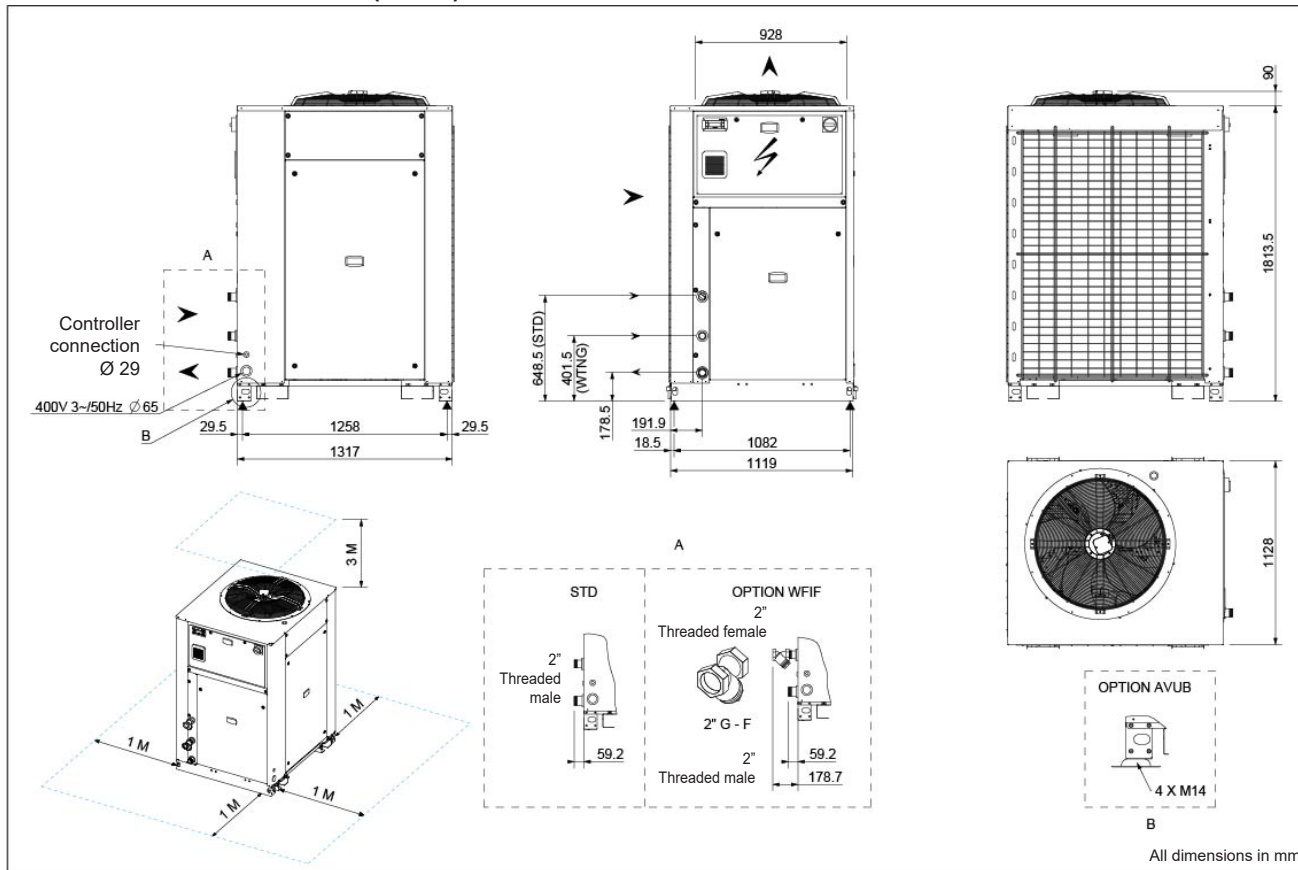

GAC-H_060S_055S_060S_S_R32_C

SPXX	Hydraulic module with single pump	KGRL	Flange connection
DPXX	Hydraulic module with twin pump	WFIF	Water filter (supplied loose)
AVUB	Rubber anti-vibration mounts		

1.- GENERAL CHARACTERISTICS

1.8.- DIMENSIONS

GAC/H 065S-070S

STANDARD VERSION OR WITH HIGH PRESSURE EC FANS (HIPF)

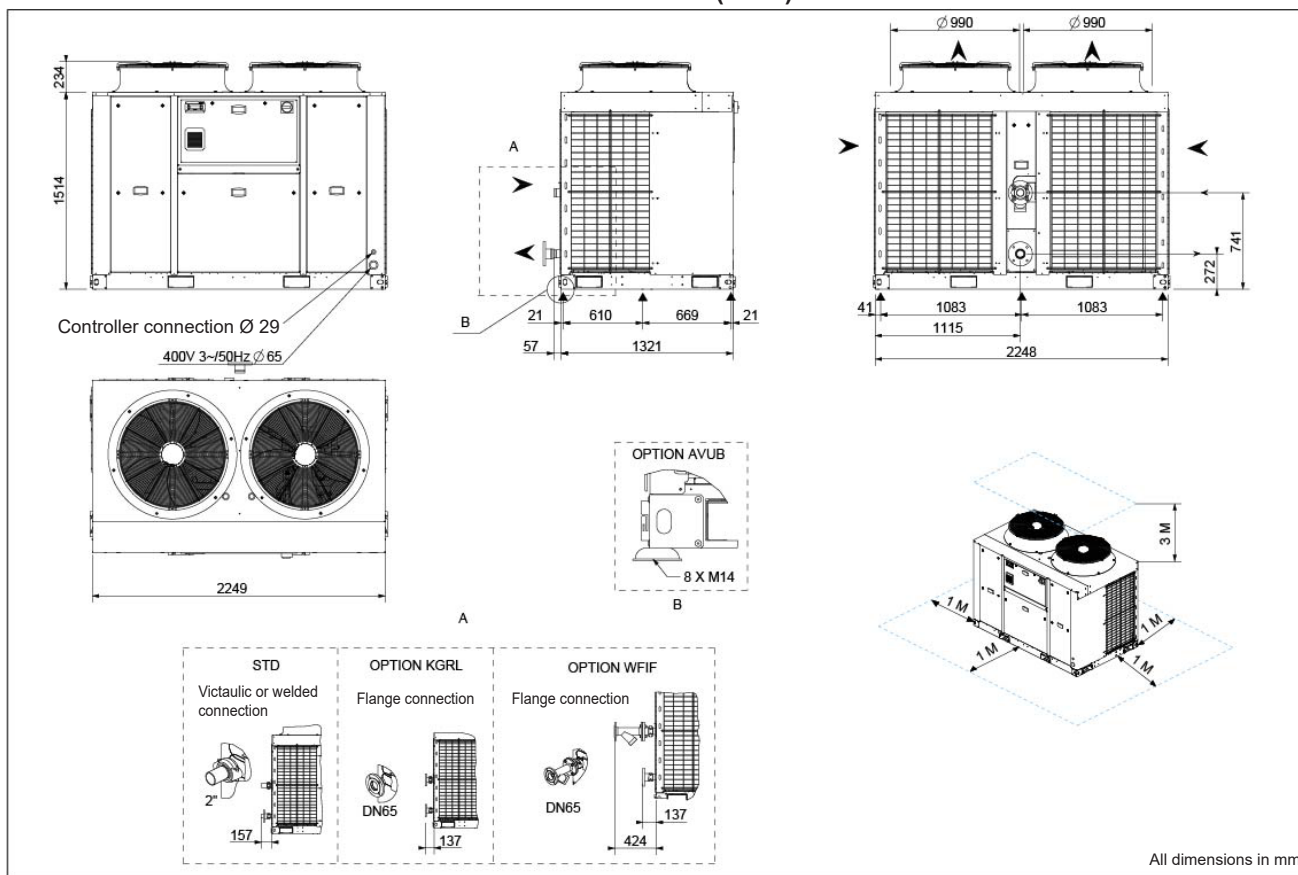

GAC-H_065S_070S_H_R32_B

UNIT WITH OPTIONAL AC FANS (SFAC)

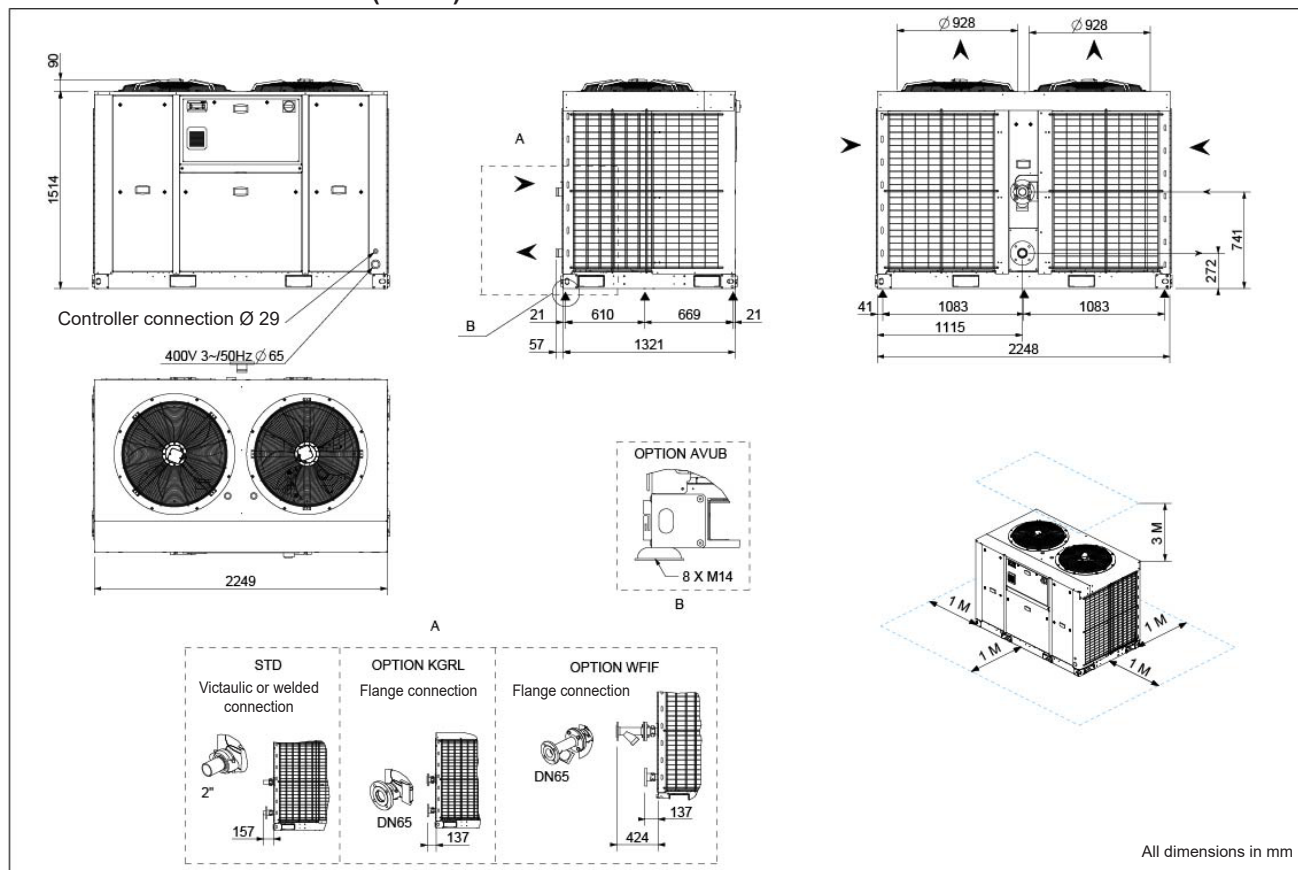

GAC-H_065S_070S_S_R32_B

SPXX	Hydraulic module with single pump
DPXX	Hydraulic module with twin pump
AVUB	Rubber anti-vibration mounts

KGRL	Flange connection
WFIF	Water filter (supplied loose)

1.- GENERAL CHARACTERISTICS

1.8.- DIMENSIONS

GAC/H 080S

STANDARD VERSION OR WITH HIGH PRESSURE EC FANS (HIPF)

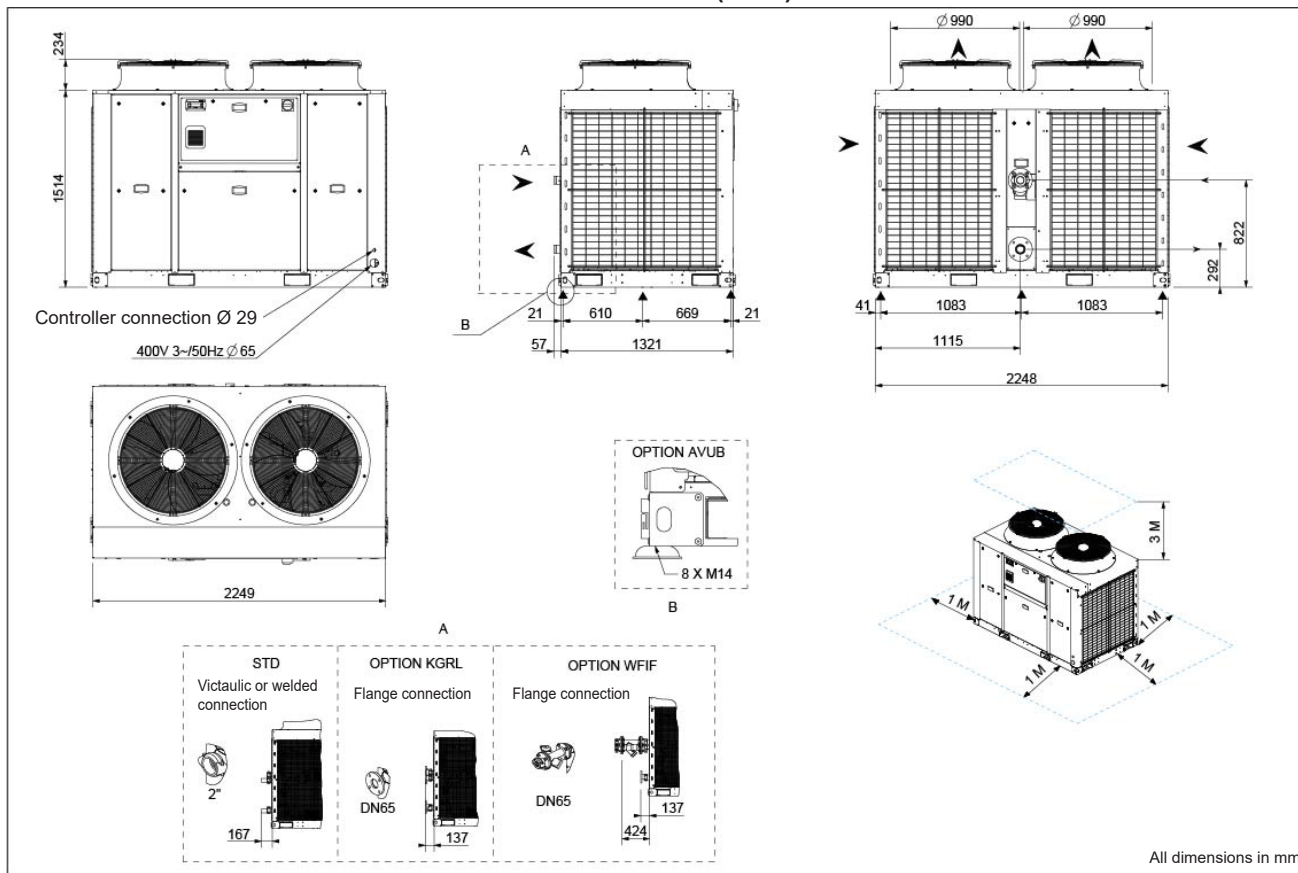

GAC-H_080S_H_R32_B

UNIT WITH OPTIONAL AC FANS (SFAC)

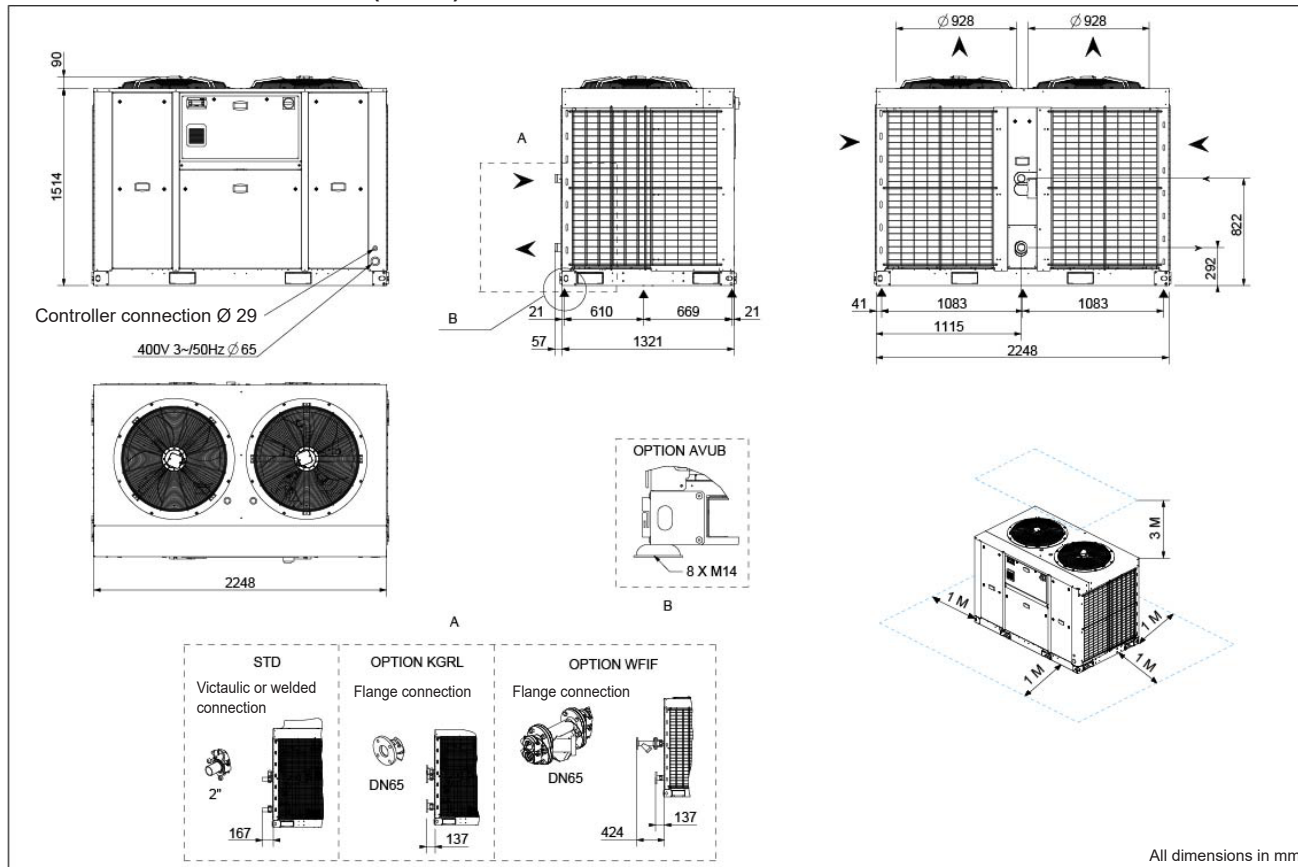

GAC-H_080S_S_R32_B

SPXX	Hydraulic module with single pump	KGRL	Flange connection
DPXX	Hydraulic module with twin pump	WFIF	Water filter (supplied loose)
AVUB	Rubber anti-vibration mounts	PHRF	Domestic hot water supply : desuperheater

1.- GENERAL CHARACTERISTICS

1.8.- DIMENSIONS

GAC/H 095S-110S-115S

STANDARD VERSION OR WITH HIGH PRESSURE EC FANS (HIPF)

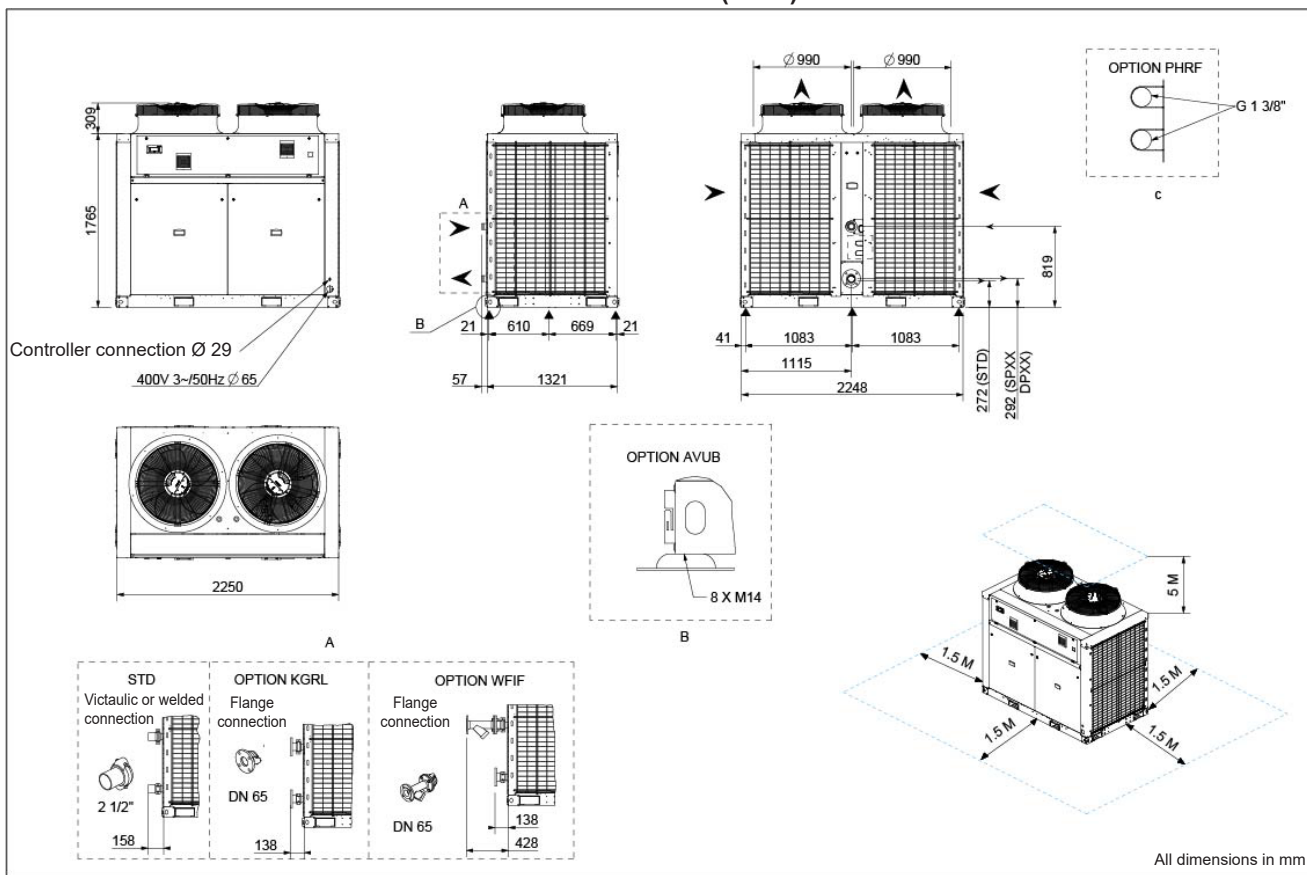

GAC-H_096S-110S-115S_H_R32_B

UNIT WITH OPTIONAL AC FANS (SFAC)

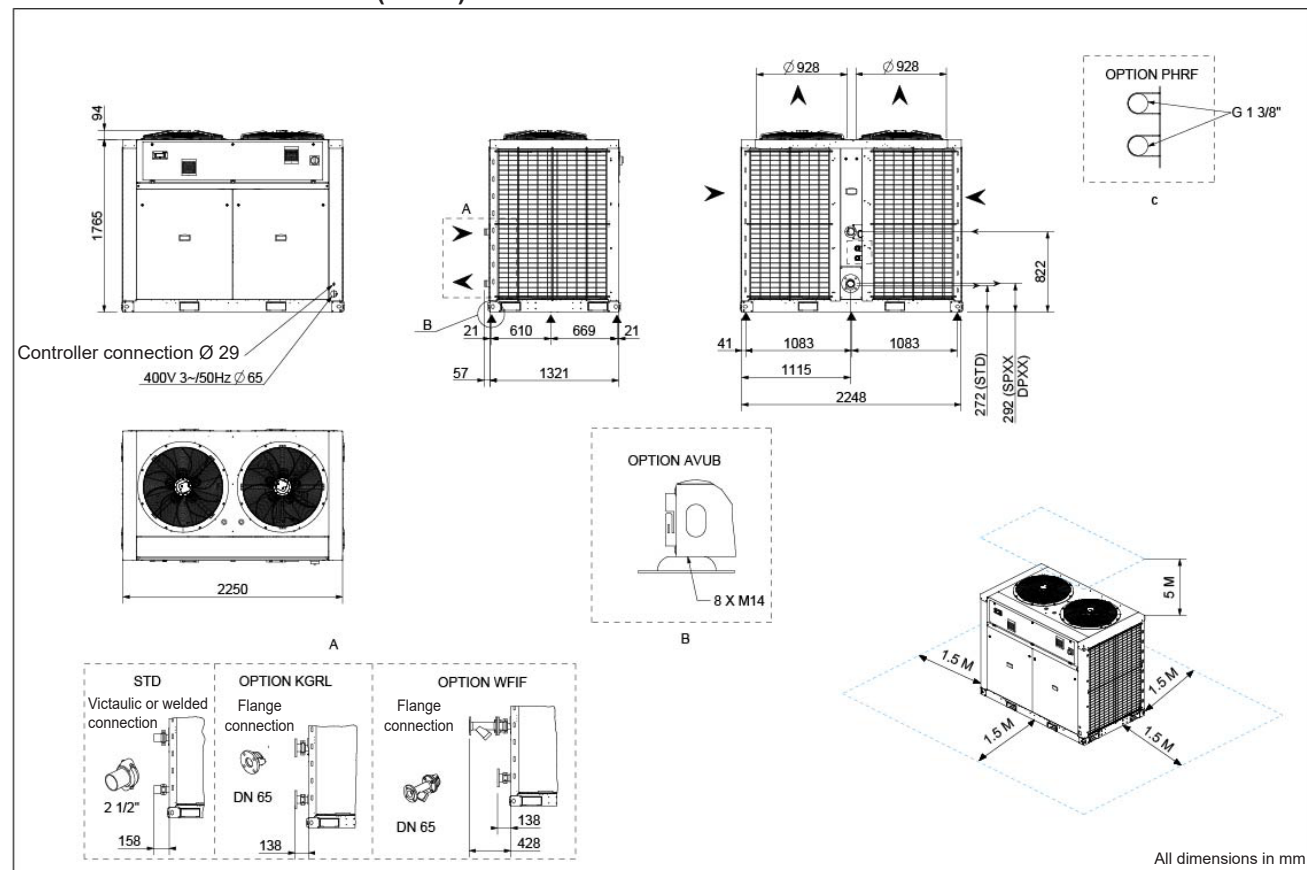

GAC-H_096S-110S-115S_S_R32_B

SPXX Hydraulic module with single pump

DPXX Hydraulic module with twin pump

AVUB Rubber anti-vibration mounts

KGRL Flange connection

WFIF Water filter (supplied loose)

PHRF Domestic hot water supply : desuperheater

1.- GENERAL CHARACTERISTICS

1.8.- DIMENSIONS

GAC/H 125S-140S

STANDARD VERSION OR WITH HIGH PRESSURE EC FANS (HIPF)

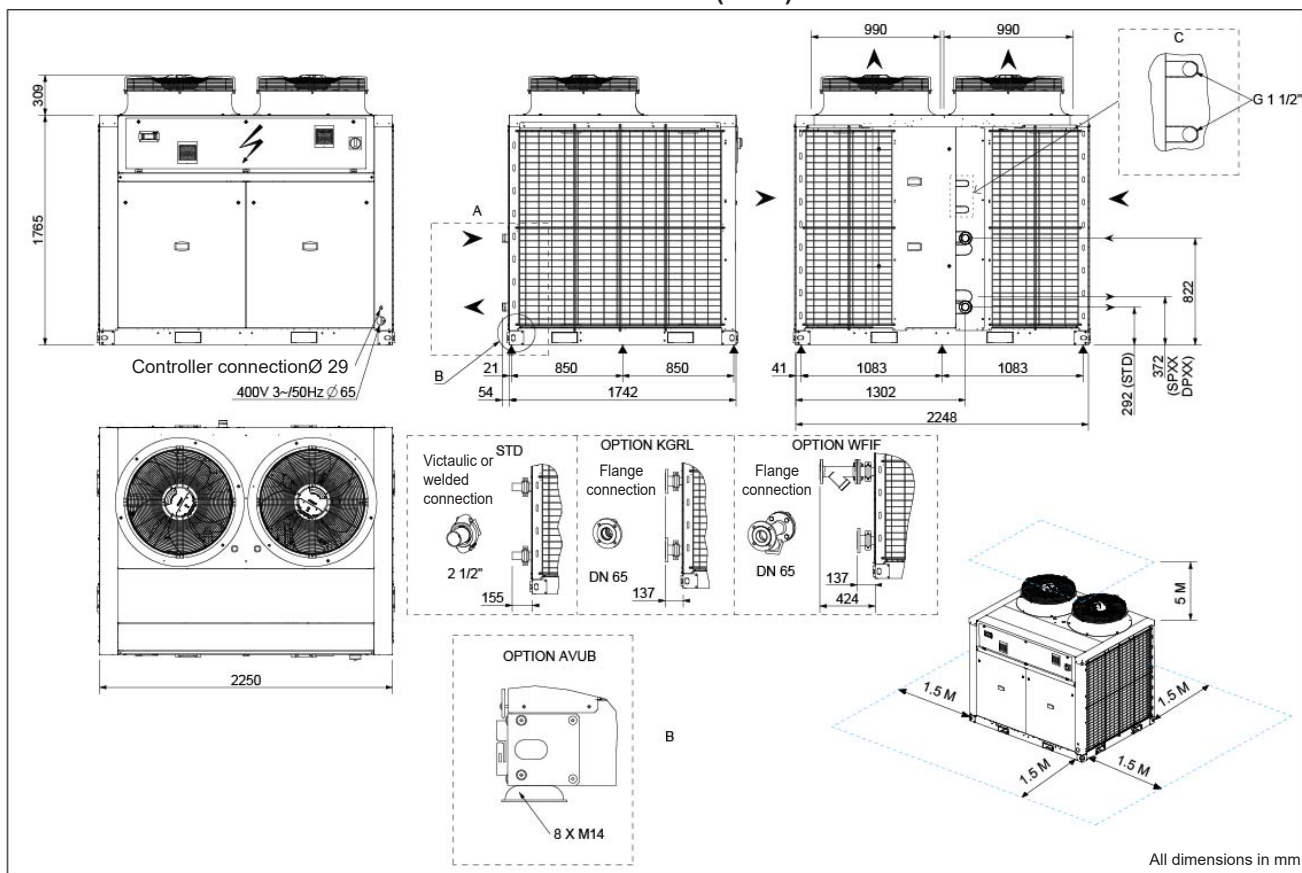

GAC-H_125S-140S_H_R32_C

All dimensions in mm

UNIT WITH OPTIONAL AC FANS (SFAC)

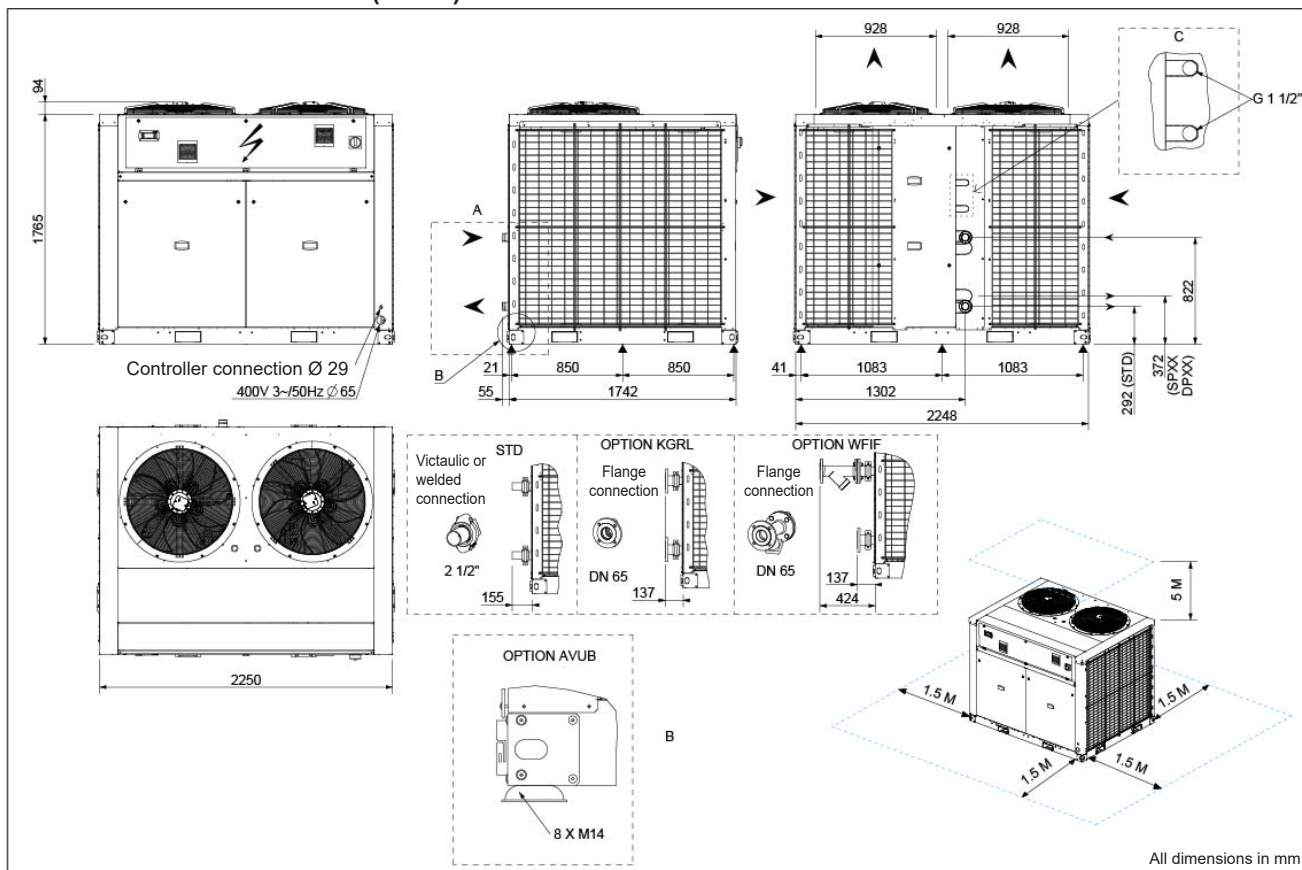

GAC-H_125S-140S_S_R32_C

All dimensions in mm

SPXX	Hydraulic module with single pump	KGRL	Flange connection
DPXX	Hydraulic module with twin pump	WFIF	Water filter (supplied loose)
AVUB	Rubber anti-vibration mounts	PHRF	Domestic hot water supply : desuperheater

1.- GENERAL CHARACTERISTICS

1.8.- DIMENSIONS

GAC/H 110D-125D-140D

STANDARD VERSION OR WITH HIGH PRESSURE EC FANS (HIPF)

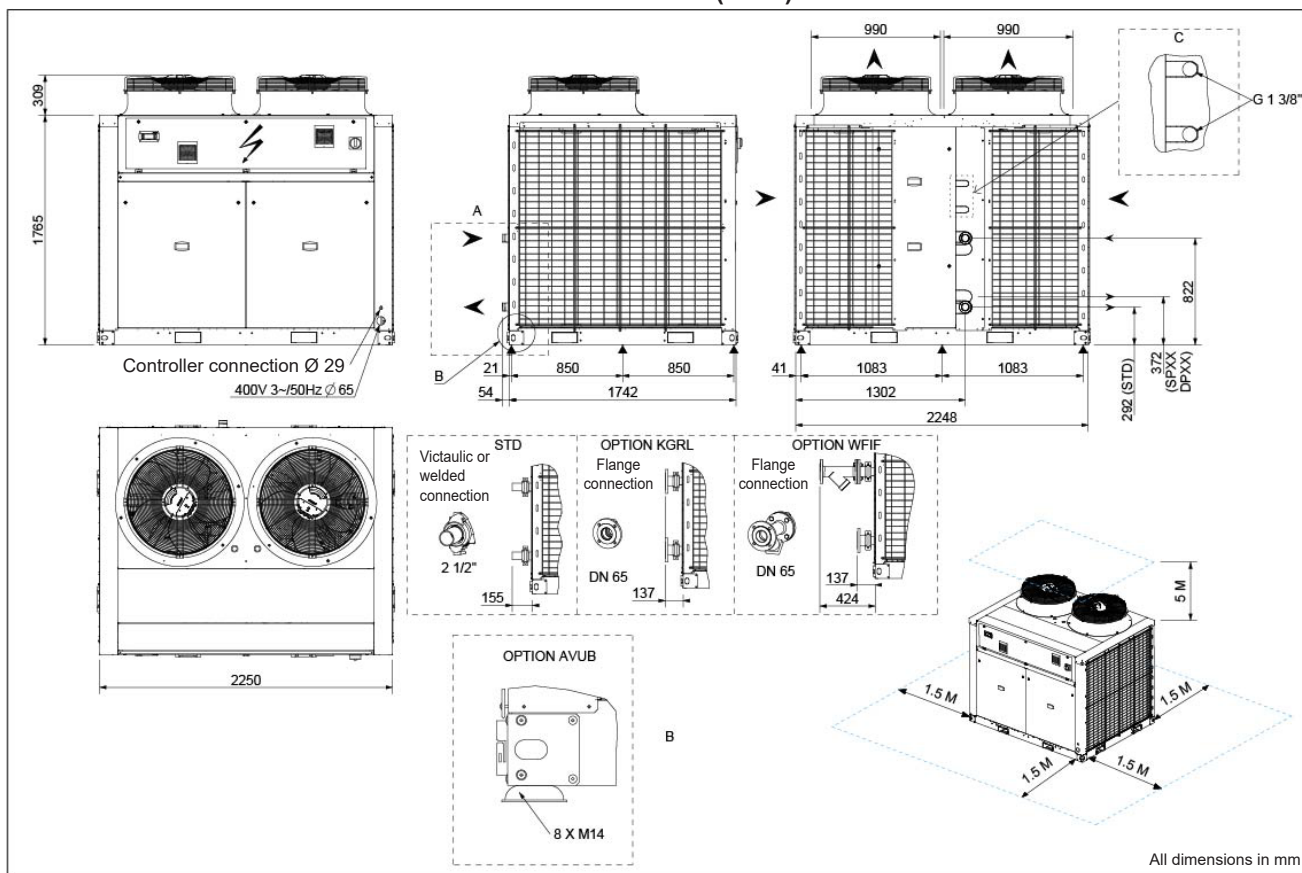

GAC-H_110D-125D-140D_H_R32_C

All dimensions in mm

UNIT WITH OPTIONAL AC FANS (SFAC)

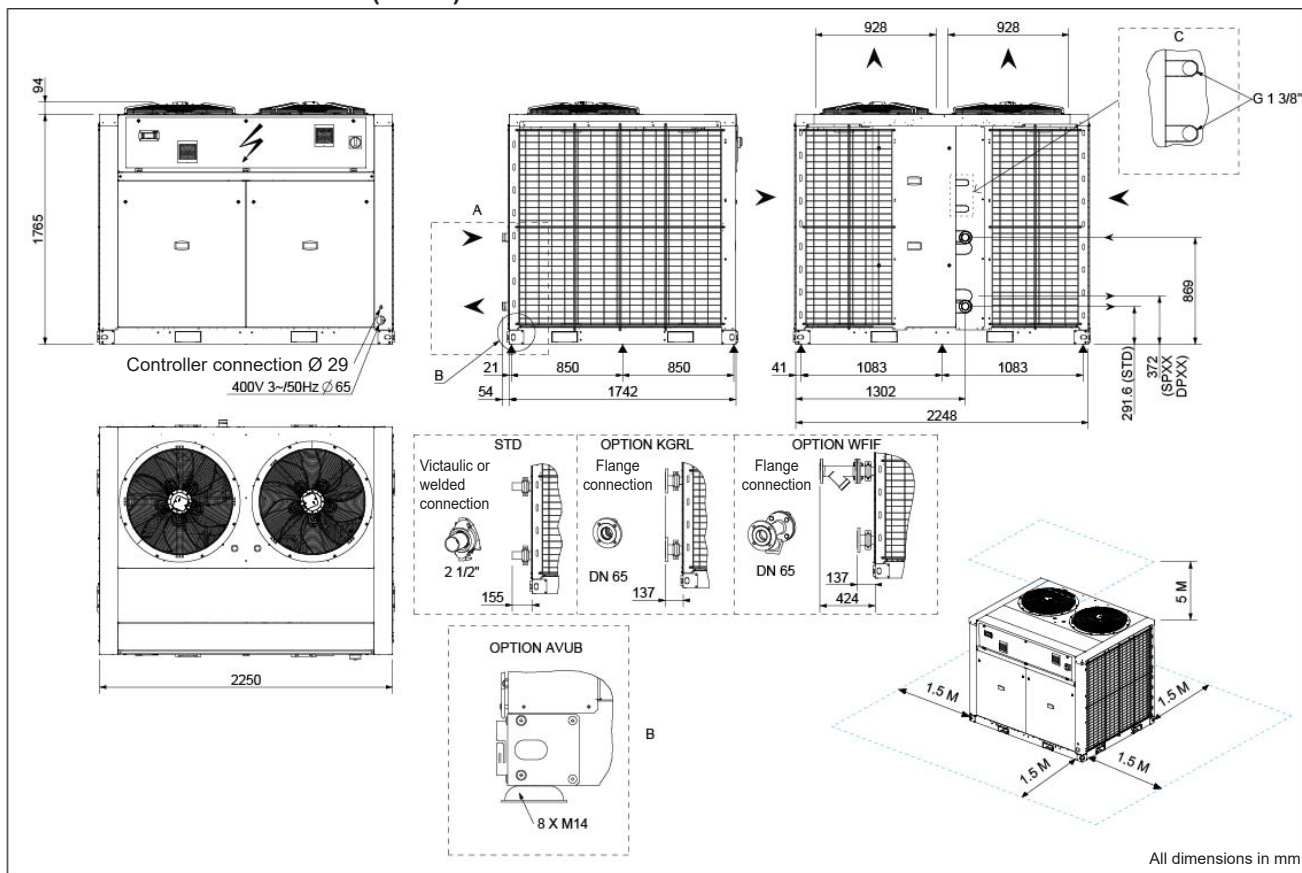

GAC-H_110D-125D-140D_S_R32_C

All dimensions in mm

SPXX	Hydraulic module with single pump	KGRL	Flange connection	WTNG	Water tank
DPXX	Hydraulic module with twin pum	WFIF	Water filter (supplied loose)		
AVUB	Rubber anti-vibration mounts	PHRF	Domestic hot water supply : desuperheater		

1.- GENERAL CHARACTERISTICS

1.8.- DIMENSIONS

GAC/H 160D-185D-210D

STANDARD VERSION OR WITH HIGH PRESSURE EC FANS (HIPF)

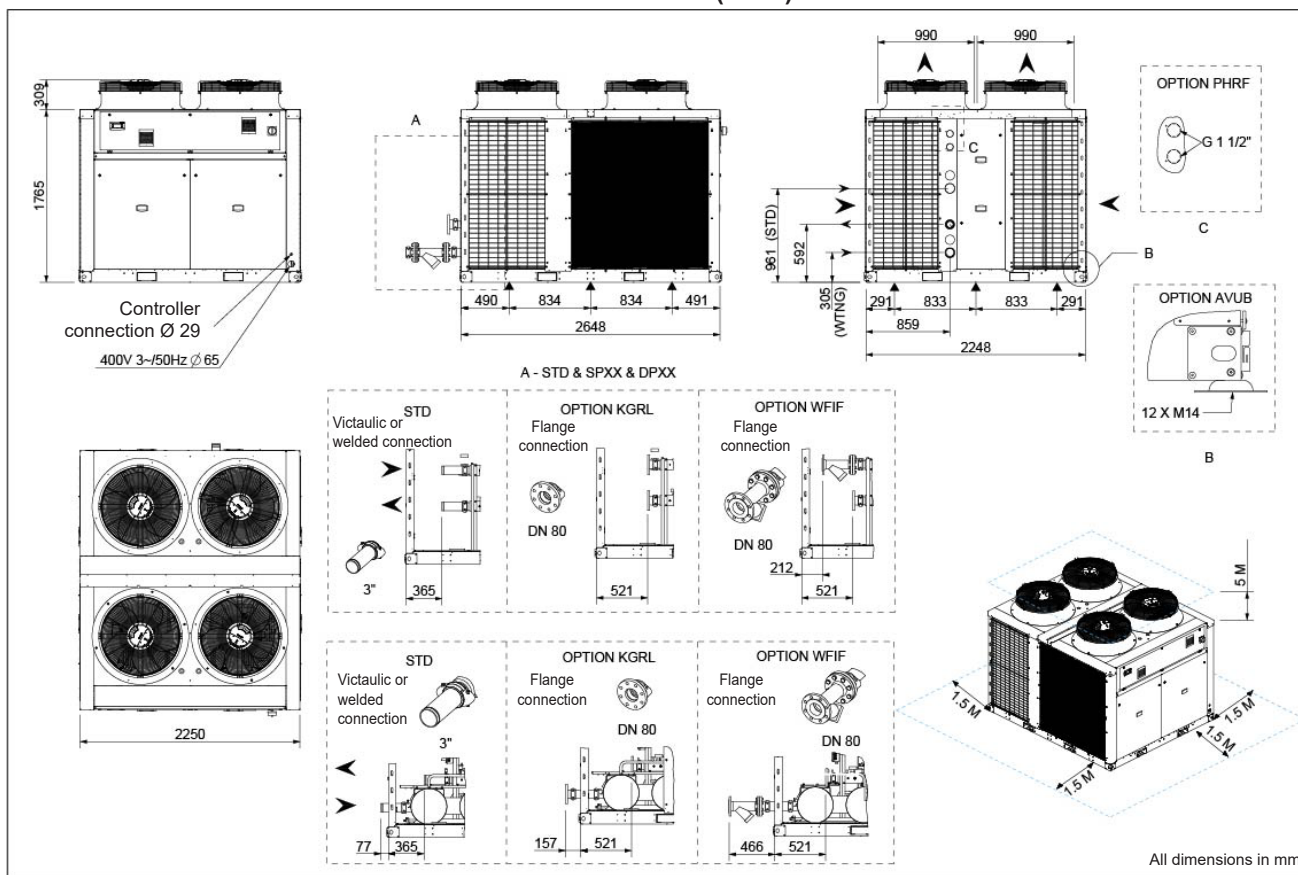

GAC-H_160D-185D-210D_H_R32_B

UNIT WITH OPTIONAL AC FANS (SFAC)

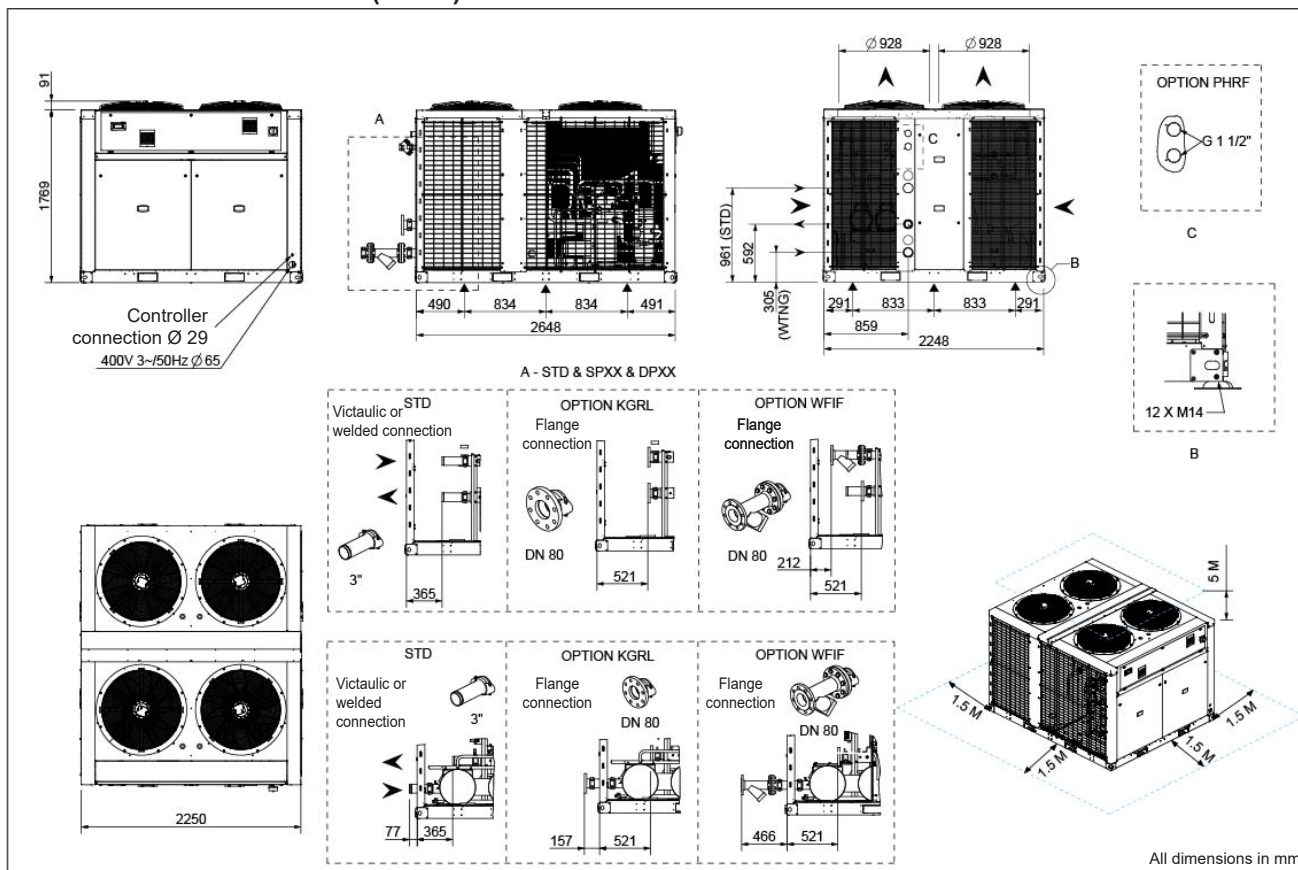

GAC-H_160D-185D-210D_S_R32_B

SPXX	Hydraulic module with single pump	KGRL	Flange connection	WTNG	Water tank
DPXX	Hydraulic module with twin pum	WFIF	Water filter (supplied loose)		
AVUB	Rubber anti-vibration mounts	PHRF	Domestic hot water supply : desuperheater		

1.- GENERAL CHARACTERISTICS

1.8.- DIMENSIONS

GBC/H 040S

STANDARD VERSION OR WITH HIGH PRESSURE EC FANS (HIPF)

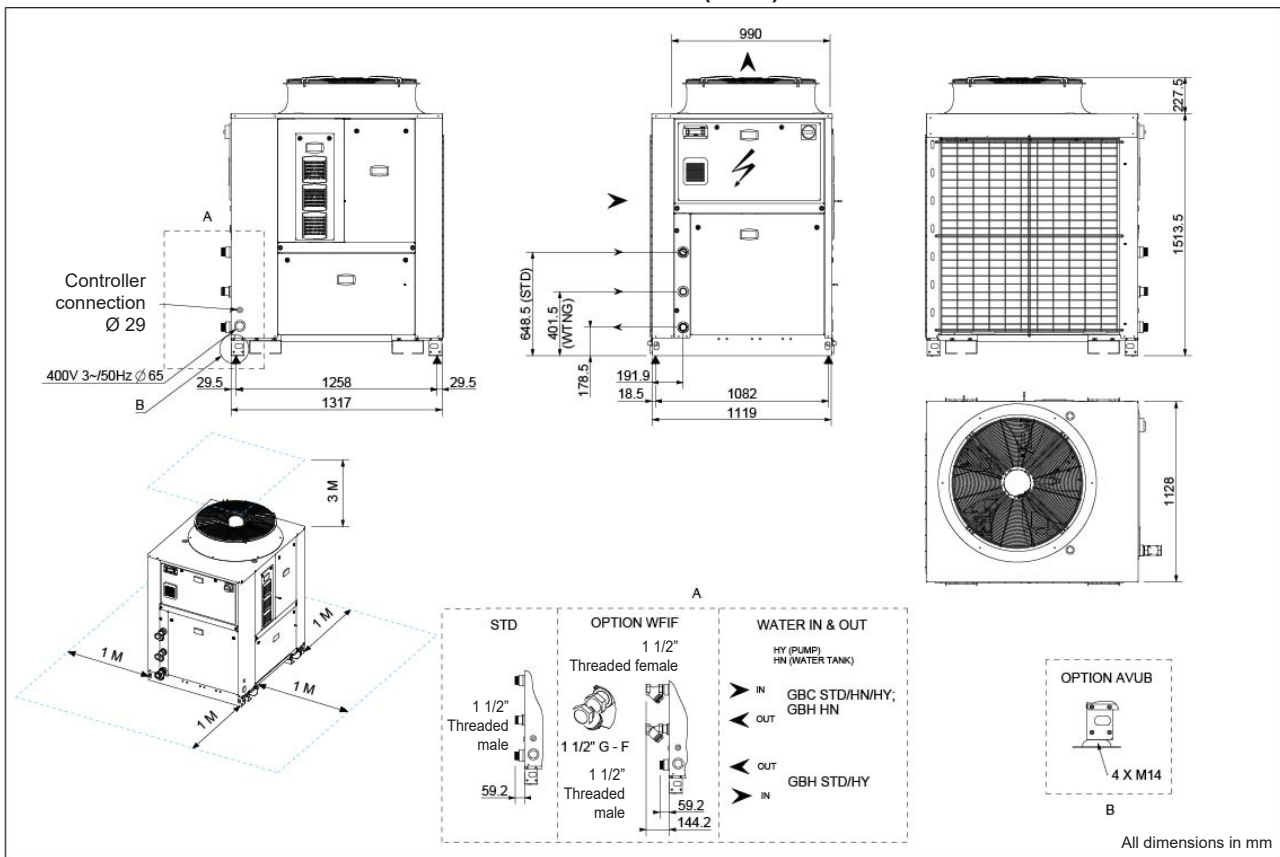

GBC/H 060S

STANDARD VERSION OR WITH HIGH PRESSURE EC FANS (HIPF)

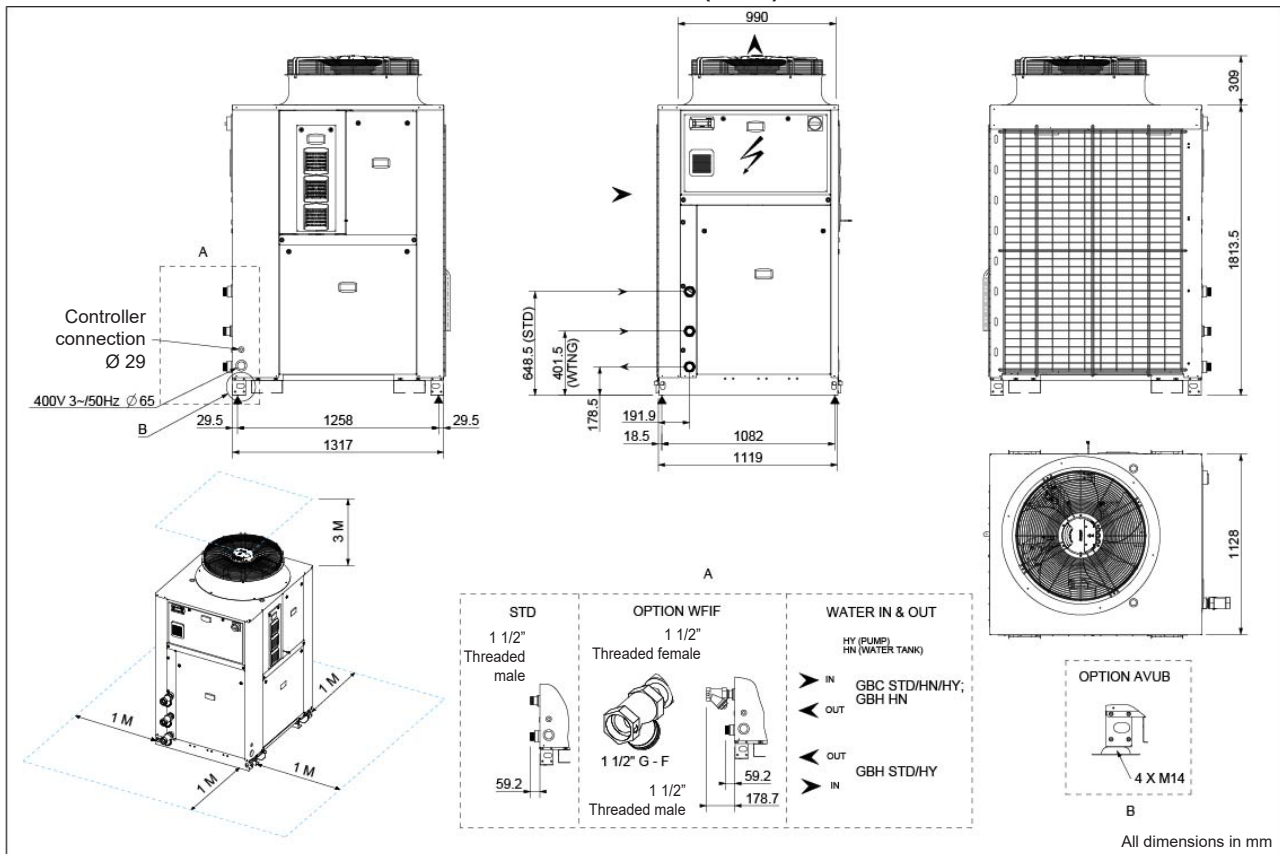

SPXX	Hydraulic module with single pump	WTNG	Water tank
DPXX	Hydraulic module with twin pump	WFIF	Water filter (supplied loose)
AVUB	Rubber anti-vibration mounts		

1.- GENERAL CHARACTERISTICS

1.8.- DIMENSIONS

GBC/H 070S

STANDARD VERSION OR WITH HIGH PRESSURE EC FANS (HIPF)

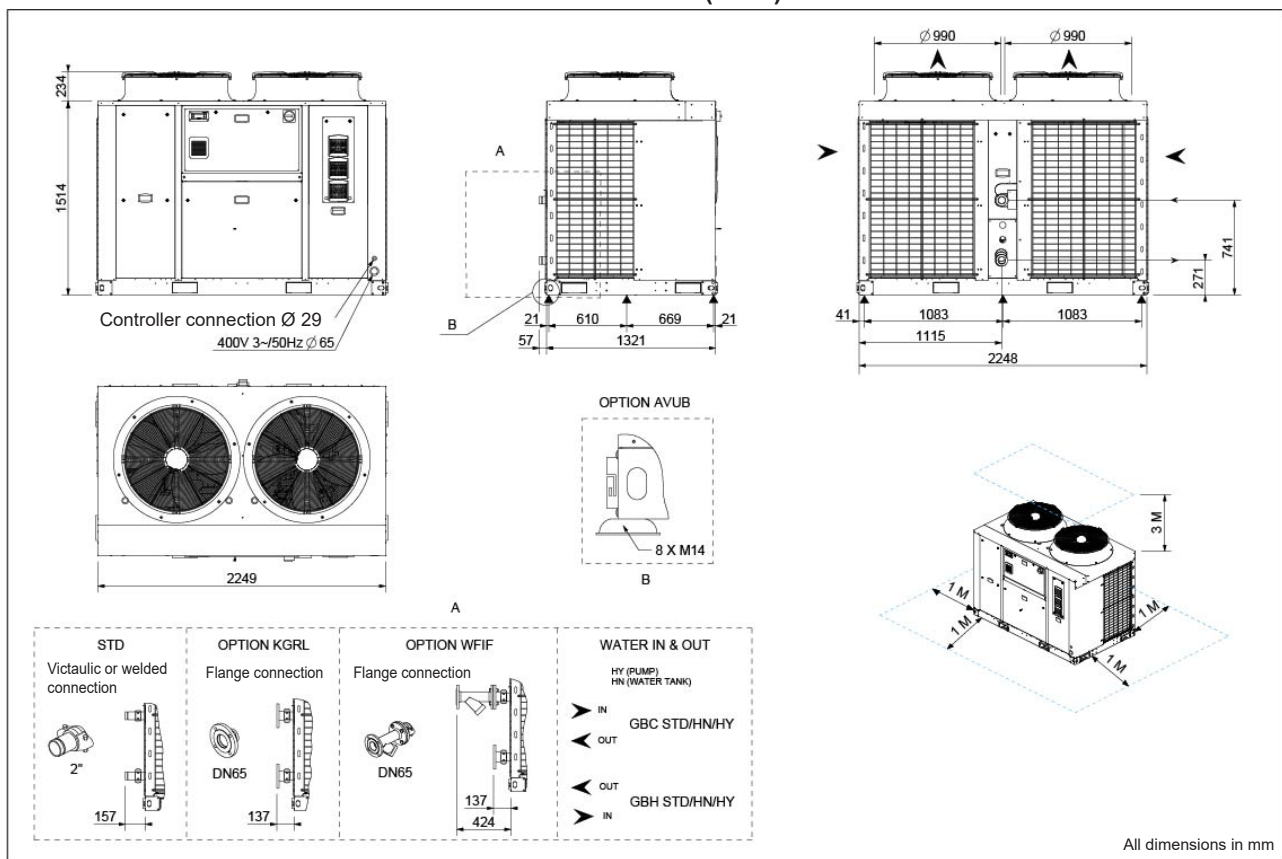

GBC/H 080S

STANDARD VERSION OR WITH HIGH PRESSURE EC FANS (HIPF)

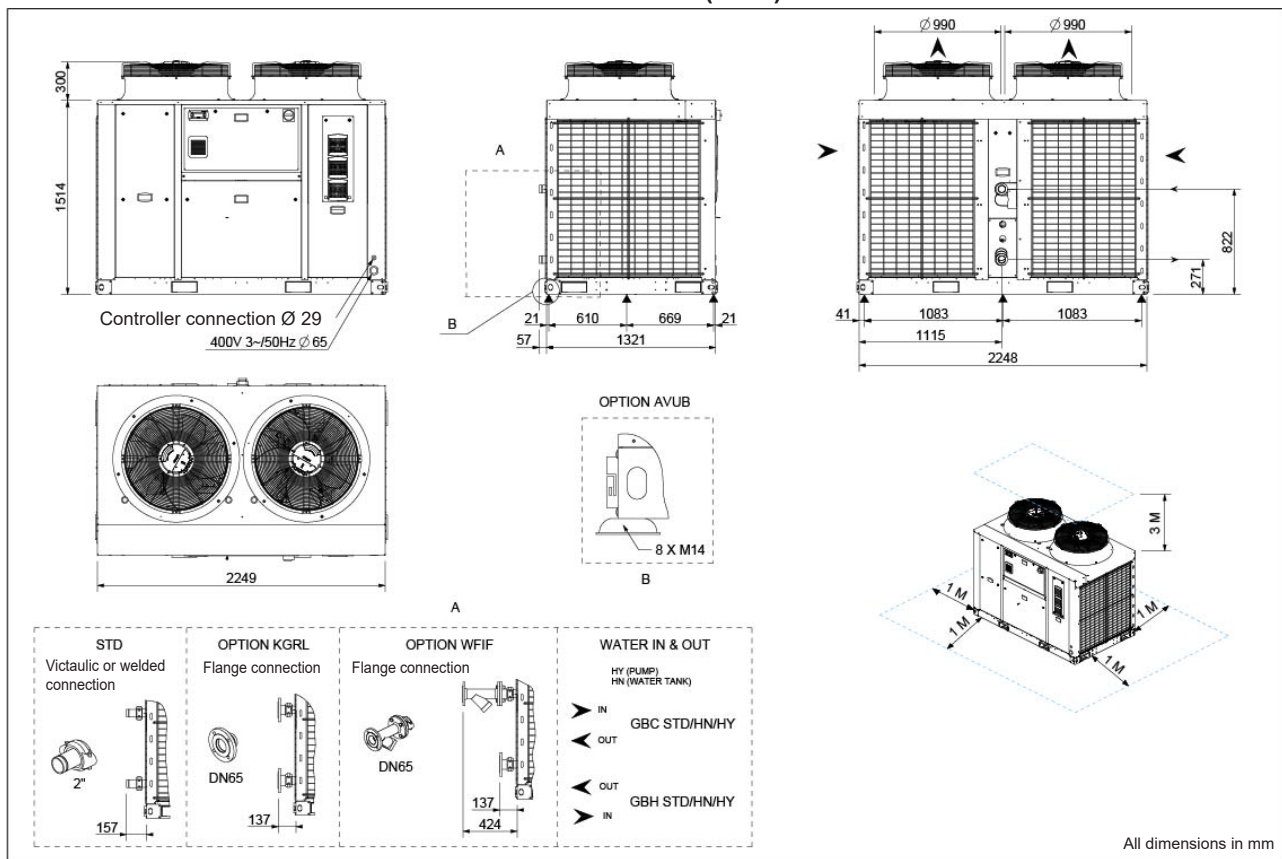

SPXX	Hydraulic module with single pump	KGRL	Flange connection
DPXX	Hydraulic module with twin pump	WFIF	Water filter (supplied loose)
AVUB	Rubber anti-vibration mounts		

1.- GENERAL CHARACTERISTICS

1.8.- DIMENSIONS

GBC/H 110S-120S

STANDARD VERSION OR WITH HIGH PRESSURE EC FANS (HIPF)

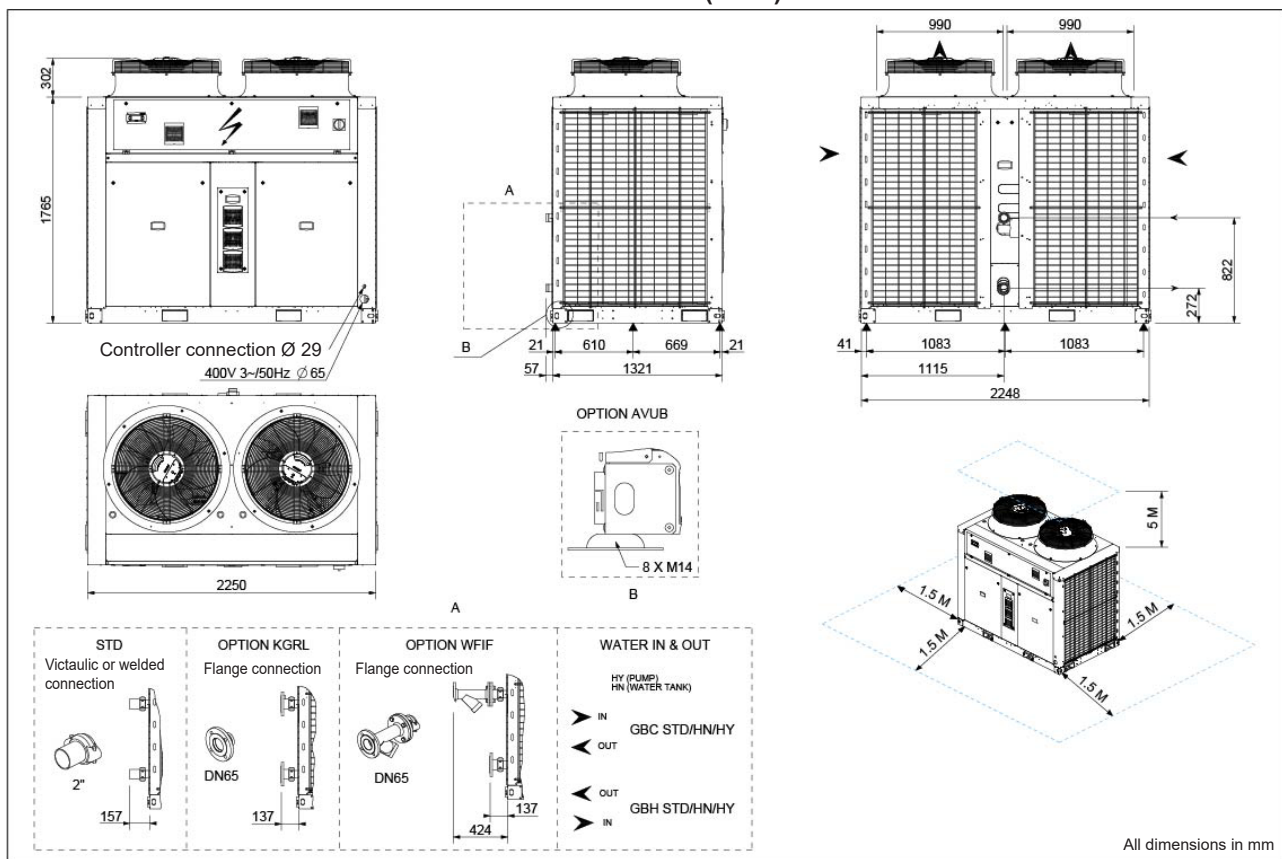

GBC 125D-140D

STANDARD VERSION OR WITH HIGH PRESSURE EC FANS (HIPF)

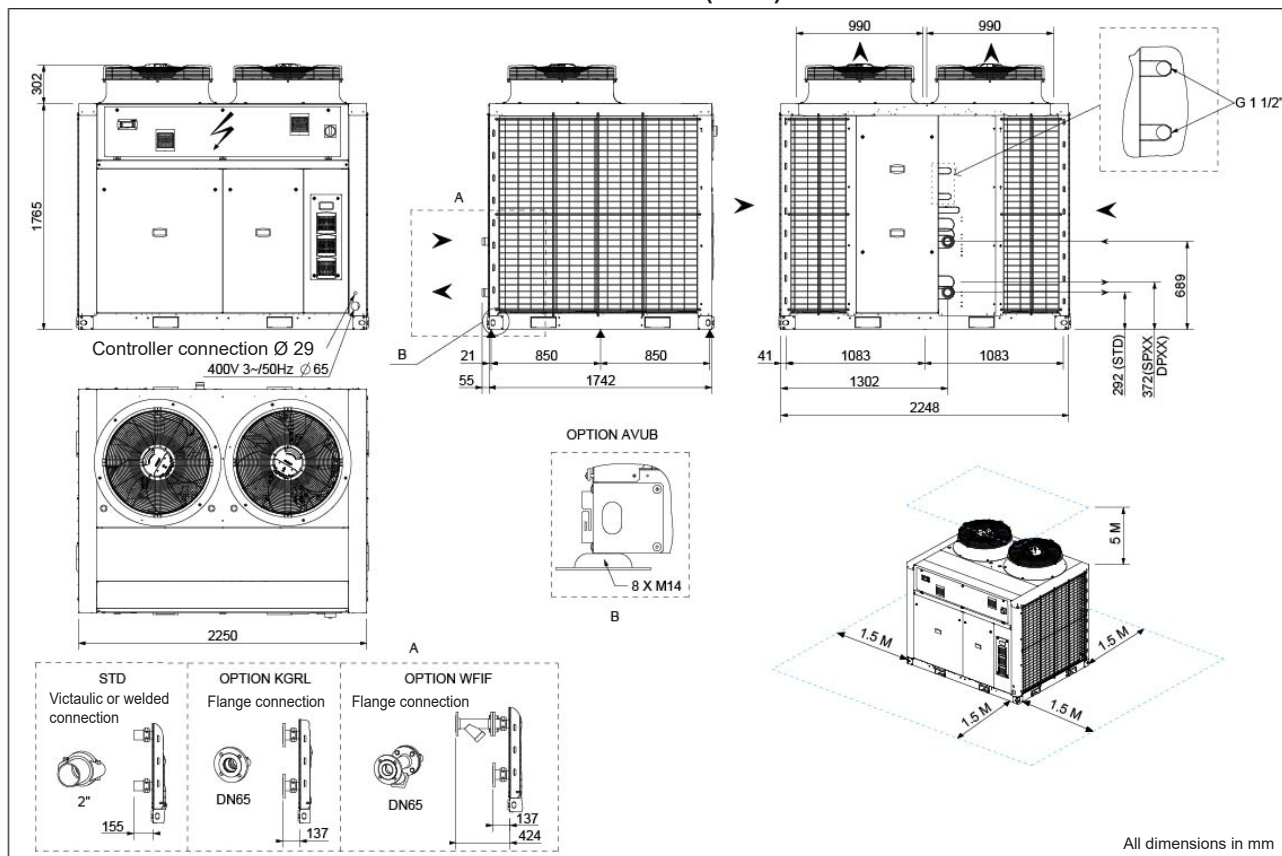

SPXX	Hydraulic module with single pump	KGRL	Flange connection
DPXX	Hydraulic module with twin pump	WFIF	Water filter (supplied loose)
AVUB	Rubber anti-vibration mounts	PHRF	Domestic hot water supply : desuperheater

1.- GENERAL CHARACTERISTICS

1.8.- DIMENSIONS

GBH 125D-140D

STANDARD VERSION OR WITH HIGH PRESSURE EC FANS (HIPF)

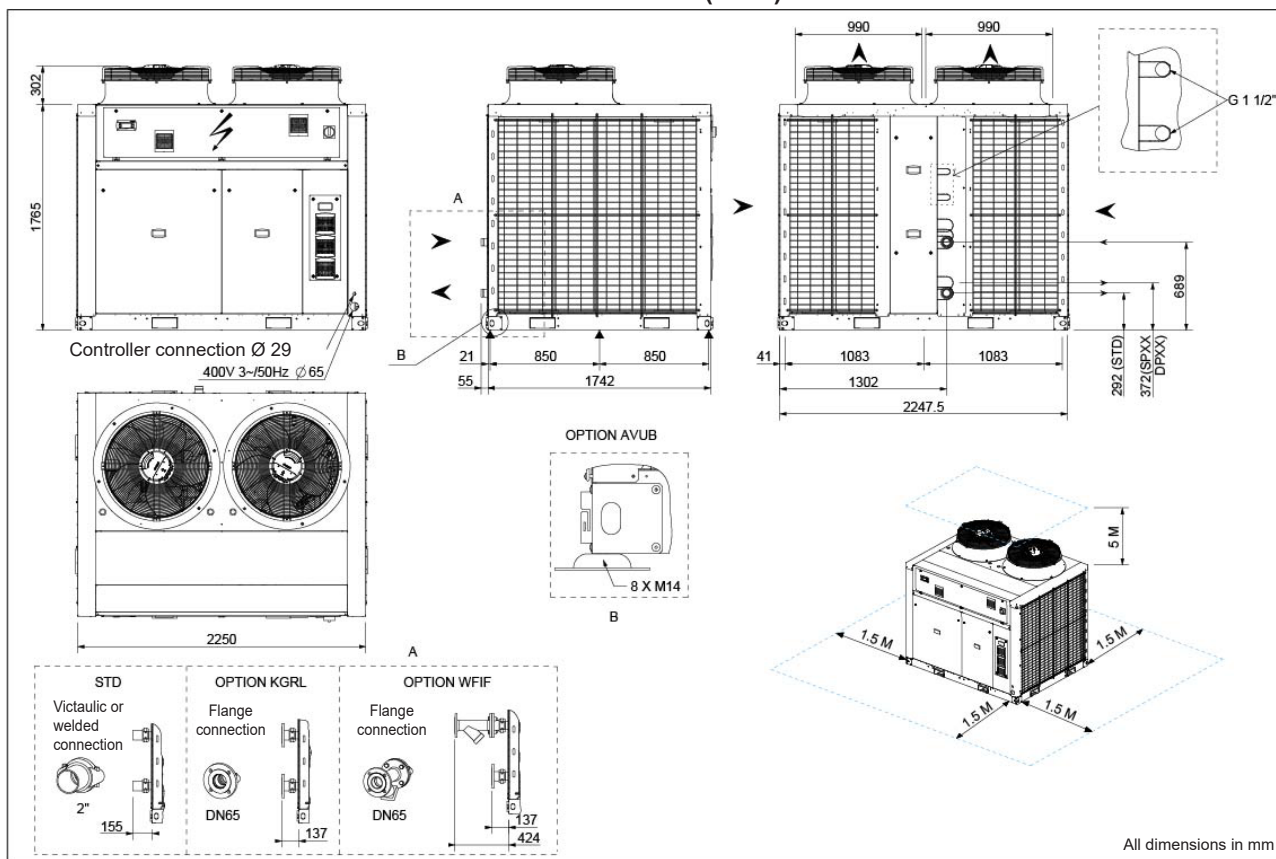

GBH_125D-140D_H_R32_A

All dimensions in mm

GBC/H 160D-185D-210D

STANDARD VERSION OR WITH HIGH PRESSURE EC FANS (HIPF)

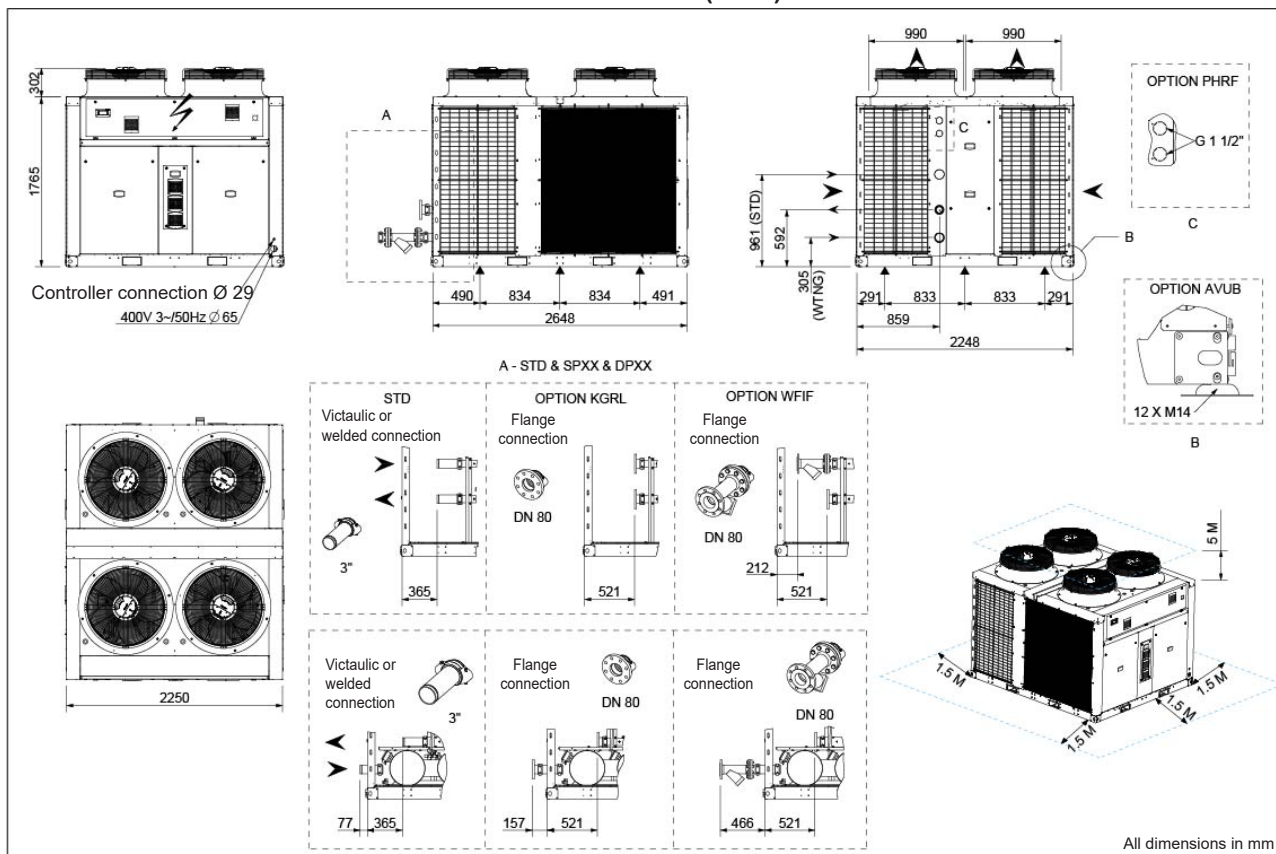

GBC-H_160D-185D-210D_H_R32_A

All dimensions in mm

SPXX	Hydraulic module with single pump	KGRL	Flange connection	WTNG	Water tank
DPXX	Hydraulic module with twin pum	WFIF	Water filter (supplied loose)		
AVUB	Rubber anti-vibration mounts	PHRF	Domestic hot water supply : desuperheater		

2.- INSTALLATION

2.1.- TRANSPORT - HANDLING

Equipment designed to withstand transport and handling according to the established protocol (for the handling protocol, please refer to the installation instructions for the relevant product range).

All unloading operations must be carried out with suitable equipment (crane, forklift truck, etc.).

Optional removable handling rings are available for certain products.

When using a forklift truck, you must respect the positions and the direction of handling indicated on the products.

The equipment must be handled with care to avoid damage to the bodywork, piping, condenser, etc.

Controls and delivery checks

After the unit has been received, when it is ready to be installed or reinstalled, and before it is started up, it must be inspected for damage. On receipt of new equipment please check the following points. It is the customer's responsibility to ensure that the products are in good working order:

- The exterior has not been damaged in any way.
- The lifting and handling equipment are suitable for the equipment and comply with the specifications of the handling instructions enclosed here-in.
- Accessories ordered for on site installation have been delivered and are in good working order.
- If the unit is delivered with its operating charge of refrigerant, that there has been no leakage (use an electronic detector).
- The equipment supplied corresponds to the order and matches the delivery note.

If the product is damaged, exact details must be confirmed in writing by registered post to the shipping company within 48 hours of delivery (working days).

A copy of the letter must be addressed to LENNOX and the supplier or distributor for information purposes. Failure to comply will invalidate any claim against the shipping company.

Please be reminded that LENNOX is not responsible for off-loading and positioning.

Unit rating plate

The rating plate provides a complete reference for the model and ensures that the unit corresponds to the model ordered. It states the electrical power consumption of the unit on start-up, its rated power and its supply voltage.

The supply voltage must not deviate beyond +5/-5%.

The start-up power is the maximum value likely to be achieved for the specified operational voltage. The customer must have a suitable electrical supply. It is therefore important to check whether the supply voltage stated on the unit's rating plate is compatible with that of the mains electrical supply.



When positioning the unit, be sure that the Rating plate will always be visible since this data will be necessary to assure proper maintenance.

2.- INSTALLATION

		LFB France (1) S.A.S ZI les Meurières 69780 Mions France					
				XXXX XXXX (3) XXXX XXXX			
Unit type: (7)							
Serial Nr : (8)							
	Voltage (V)	Phase (Ph)	Frequency (Hz)	Current (A)			
Elec Supply	(10)	(11)	(12)	Nominal	Starting		
Elec Aux.	(13)	(14)	(15)	(16)	(17)		
			Min (a)	Max (b)			
			LP(c)	HP(d)	LP(c)		
Pressure (PS) (bar)					(18)		
Temperature (TS) (°C)					(19)		
Storage Temperature (°C)					(20)		
LP : Low Pressure side / HP : High Pressure side							
Nominal Capacity (kW)		Ref Charge (kg)/ Tonne of CO2 equivalent (t, CO2)				Dates	
Cooling	Heating	Eq1	Eq2	Eq3	Eq4	Prod.	Test
(21)	(22)	(23)	/	/	/	(25)	(26)
		(24)					
Fluid		(27)				Weight (kg) +/-5%	
Fluid Group		(28)				(29)	
This product is used for Air Conditioning. Contains fluorinated greenhouse gases covered by the Kyoto protocol. Hermetically sealed equipment (30)							

The rating plate indicates:

- (1) Address.
- (2) Regulatory marking.
- (3) Identification number of the notified body only if the product is subject to the Pressure Equipment Directive (2014/68/EU - PESR 2016 - Gas appliance: 2016/426/EU - GAR 2016/426).
- (4) «To be read» pictogram.
- (5) Regulatory marking.
- (6) QR code, unit documentation link.
- (7) Unit type.
- (8) Serial number.
- (9) Flammable fluid type pictogram.
- (10) Power part voltage.
- (11) Power part phase.
- (12) Power part phase frequency.
- (13) Control part voltage.
- (14) Control part phase.
- (15) Control part frequency.
- (16) Nominal current.
- (17) Start-up current.
- (18) Minimum (a) / maximum (b) operating pressure low (c) / high (d) pressure side.
- (19) Minimum (a) / maximum (b) operating temperature low (c) / high (d) pressure side.
- (20) Minimum (a) / maximum (b) storage temperature low (c) / high (d) pressure side.
- (21) Nominal capacity in cooling mode.
- (22) Nominal capacity in heating mode.
- (23) Refrigerant charge per circuit.
- (24) Equivalent ton of CO₂ refrigerant per circuit.
- (25) Year of production.
- (26) Date of end of line test of the unit.
- (27) Type of refrigerant and global warming potential (GWP).
- (28) Refrigerant group.
- (29) Unit weight.
- (30) Message: "This product is used for Air Conditioning. Contains fluorinated greenhouse gases covered by the Kyoto Protocol. Hermetically sealed equipment".

2.- INSTALLATION

When unpacking the machine, have a correct segregation of non-hazardous waste coming from packaging: Plastic film or other plastic elements, metal strips, wood and pallets, through authorized dealers, or segregate them in the containers destined for this purpose
Follow the installation instructions established in this manual to avoid disturbing noise caused by movement or shocks due to deficient installation of the unit.

2.2.- SITE AND SHIPPING GUIDANCE



All INSTALATION, SERVICE, and MAINTENANCE operations must be carried out by QUALIFIED PERSONNEL

The unit must be transported in a HORIZONTAL POSITION on its metal bedplate profiles. Any other position may cause serious damage to the machine.

When the unit is received, it should be checked to assure that there are no bumps or other damage, following the instructions on the packaging. If there is damage, the unit may be rejected by notifying the LENNOX Distribution Departent and reporting why the machine is unacceptable on the transport agent's delivery notice. Any later complaint or claim made to the LENNOX Distribution Departent, for this type of anomaly, cannot be considered under the Guarantee.

Sufficient space must be allowed to facilitate placement of the unit. The unit may be mounted outdoors. There should be adequate drainage around the unit.

In heat pump units during defrost cycle, the units produce a great amount of water melting the ice off coils.

If you wish to drain the water, adequate drainage should be installed behind the unit to collect and carry out the water where desired.



When positioning the unit, be sure that the Rating Plate will always be visible since this data will be necessary to assure proper maintenance.

It is advisable to unpack the unit at the place where the unit is going to be installed, to avoid damages during manage.

2.3.- UNIT LIFTING

How to hoist the unit

If unloading and placement requires the use of a crane, then secure the suspension cables as shown in the figure. The unit can only be lifted and moved by its base.

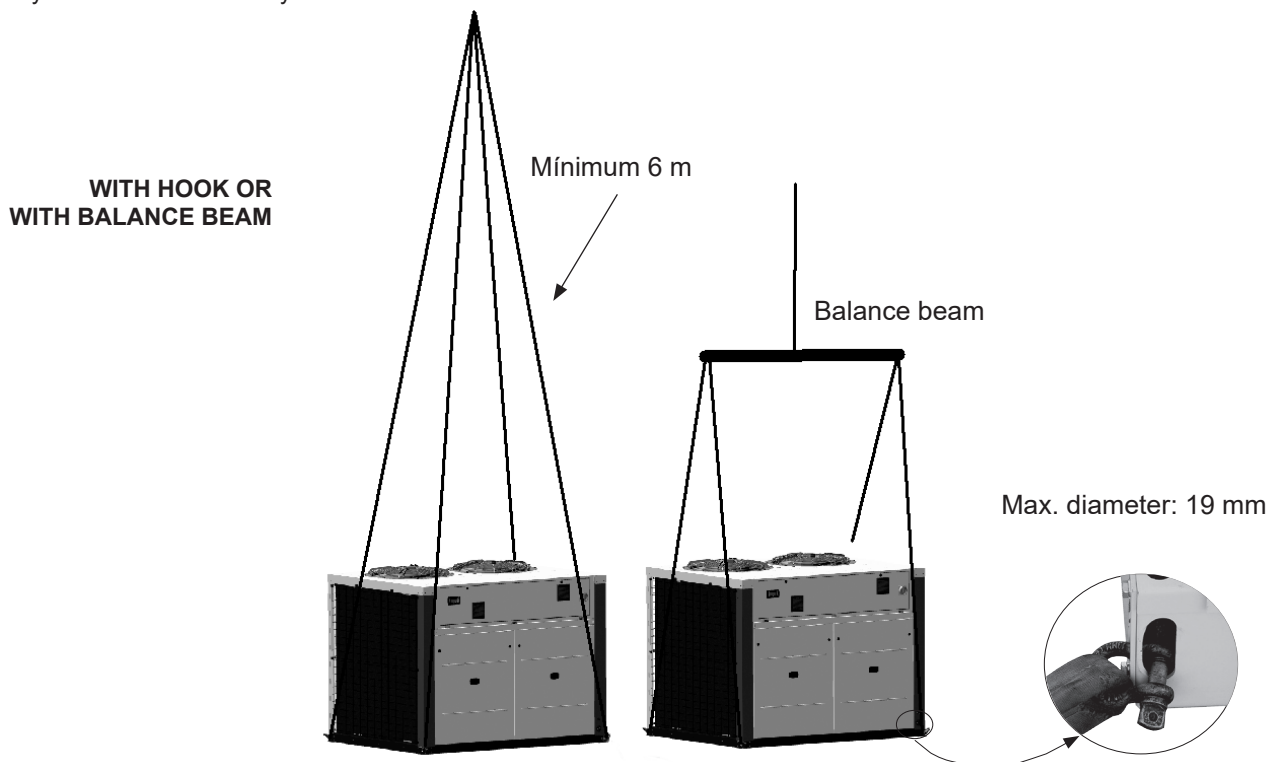

NOTE: Use slingers of 6m with the hook in order to prevent pressure on the top of the unit because it can be damaged. Whenever it is possible, use balance beam.

2.- INSTALLATION

2.4.- ANTIVIBRATION MOUNTING

1. Mounting on a low sensibility zone

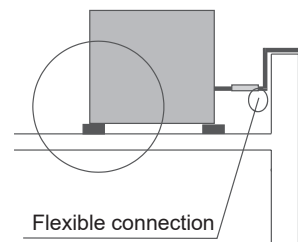
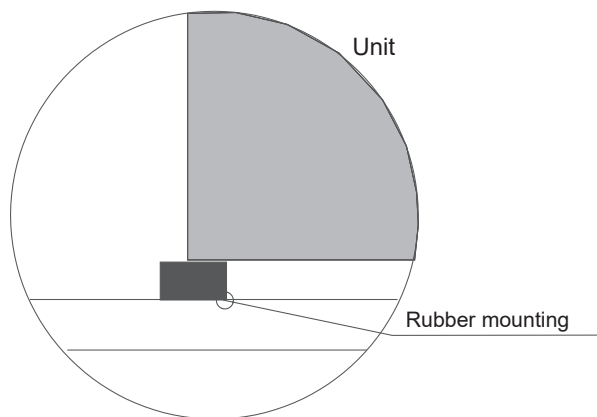

2. Mounting on a medium sensibility zone

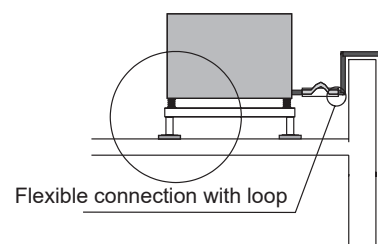
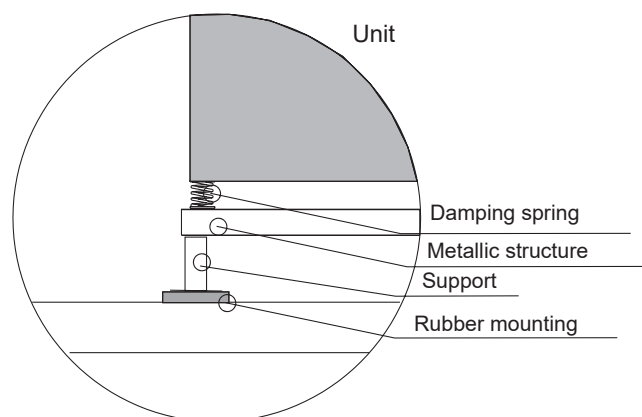

3. Mounting on a high sensibility zone (Check floor load)

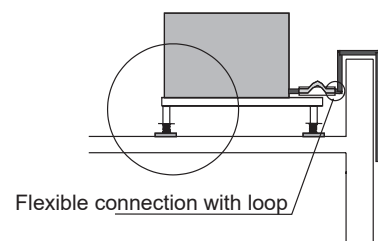
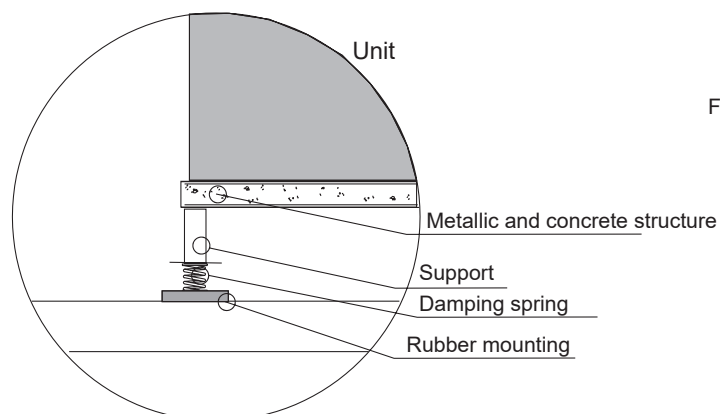

2.- INSTALLATION

2.5.- WEIGHT DISTRIBUTION (kg)

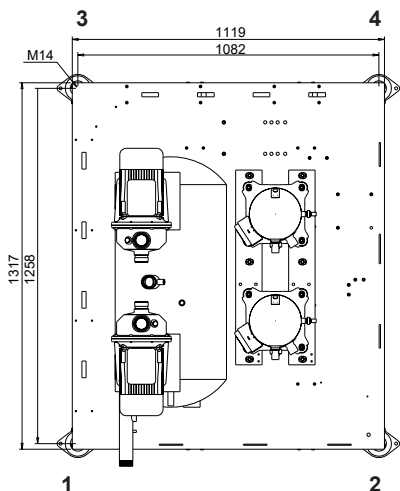

Nr. Position	STD Unit					With Dual Pump					With Dual Pump & Water Tank				
	1	2	3	4	Total (Kg)	1	2	3	4	Total (Kg)	1	2	3	4	Total (Kg)
GAC035SP1M	71	82	79	93	325	89	90	96	96	371	171	128	174	131	604
GAC040SP1M	75	87	82	95	339	93	94	99	99	385	176	132	177	133	618
GAC045SP1M	76	89	85	100	350	94	97	101	104	396	177	135	180	137	629
GAC050SP1M	85	95	94	105	379	106	104	113	112	435	257	193	261	197	908
GAC055SP1M	86	96	96	107	385	107	106	115	113	441	257	195	263	199	914
GAC060SP1M	90	103	99	113	405	112	112	118	119	461	262	203	264	205	934
GAH035SP1M	75	87	87	101	350	93	94	104	105	396	175	133	182	139	629
GAH040SP1M	81	92	92	104	369	99	99	108	109	415	181	138	187	142	648
GAH045SP1M	82	96	95	112	385	100	103	112	116	431	182	142	191	149	664
GAH050SP1M	91	107	100	118	416	112	117	119	124	472	262	208	265	210	945
GAH055SP1M	92	109	102	121	424	113	118	122	127	480	262	209	268	214	953
GAH060SP1M	97	117	106	128	448	118	126	126	134	504	267	218	271	221	977

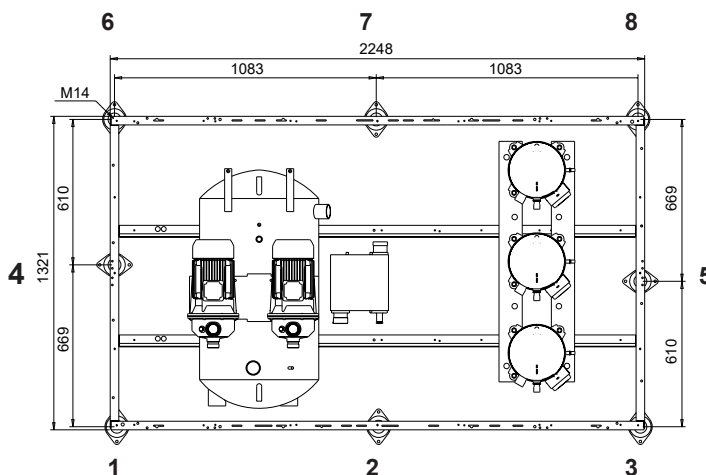

Nr. Position	STD Unit									With Dual Pump								With Dual Pump & Water Tank									
	1	2	3	4	5	6	7	8	Total (Kg)	1	2	3	4	5	6	7	8	Total (Kg)	1	2	3	4	5	6	7	8	Total (Kg)
GAC065SP1M	87	67	116	37	51	48	79	80	565	107	67	128	37	52	63	85	82	621	243	147	149	95	57	178	142	83	1094
GAC070SP1M	87	66	116	37	51	48	75	79	559	107	67	128	31	52	63	85	82	615	241	147	147	95	57	177	142	82	1088
GAC080SP1M	92	67	133	39	53	54	84	83	605	123	69	128	45	52	68	88	88	661	253	150	159	96	59	183	146	88	1134
GAC095SP1M	92	69	137	36	50	88	76	131	679	113	71	144	42	51	105	81	134	741	232	162	238	100	57	234	171	124	1318
GAC110SP1M	98	69	144	38	52	89	80	131	701	119	71	151	44	54	105	86	133	763	279	169	170	103	60	259	157	143	1340
GAC115SP1M	105	70	151	40	55	91	85	133	730	127	72	158	46	56	106	91	136	792	285	163	214	101	52	238	167	149	1369
GAH065SP1M	99	67	128	37	51	60	79	93	614	120	67	140	37	52	75	85	94	670	259	148	163	83	57	193	142	98	1143
GAH070SP1M	98	66	127	37	51	61	75	93	608	119	67	140	32	52	75	85	94	664	257	148	160	83	57	193	142	97	1137
GAH080SP1M	103	67	145	39	53	64	84	94	649	134	69	139	45	52	79	88	99	705	267	150	164	96	59	194	146	102	1178
GAH095SP1M	107	69	153	36	50	104	76	147	742	129	71	160	42	51	120	81	150	804	298	162	189	105	57	265	151	154	1381
GAH110SP1M	115	69	162	38	52	106	80	149	771	137	71	167	44	54	122	86	152	833	300	169	195	107	60	268	156	155	1410
GAH115SP1M	121	70	167	40	55	106	85	149	793	143	72	173	46	56	122	91	152	855	311	164	202	109	62	267	161	156	1432

2.- INSTALLATION

2.5.- WEIGHT DISTRIBUTION (kg)

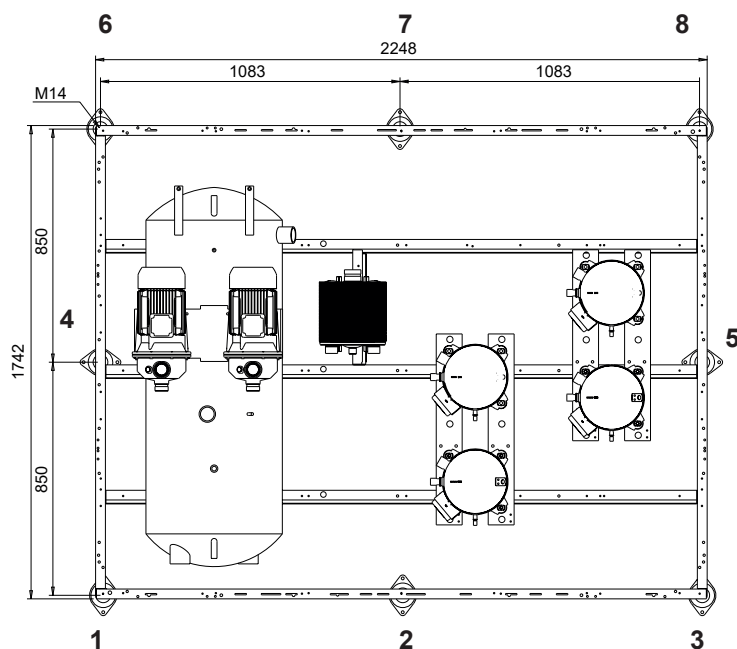

Nr. Position	STD Unit									With Dual Pump									With Dual Pump & Water Tank								
	1	2	3	4	5	6	7	8	Total (Kg)	1	2	3	4	5	6	7	8	Total (Kg)	1	2	3	4	5	6	7	8	Total (Kg)
GAC125SP1M	104	59	120	85	146	120	72	140	846	118	64	125	101	150	134	76	140	908	227	99	140	285	163	295	116	160	1485
GAC140SP1M	123	63	143	90	158	129	69	157	932	135	70	145	106	170	147	77	144	994	235	109	147	280	215	288	118	179	1571
GAC110DP1M	117	59	133	85	147	131	70	151	893	131	64	132	104	152	145	73	154	955	240	99	154	286	166	305	115	167	1532
GAC125DP1M	123	62	141	90	156	132	71	157	932	135	67	141	106	163	147	75	160	994	237	107	150	263	215	291	121	187	1571
GAC140DP1M	117	62	137	95	160	124	70	146	911	135	69	145	127	175	151	73	150	1025	306	109	214	342	254	365	119	246	1955
GAH125SP1M	121	59	138	85	148	138	72	157	918	135	64	142	101	150	151	76	161	980	244	99	157	285	163	312	116	181	1557
GAH140SP1M	135	65	158	90	170	143	74	171	1006	149	70	162	106	172	158	77	174	1068	255	105	175	290	186	314	118	202	1645
GAH110DP1M	136	59	153	87	150	150	70	170	975	150	64	157	104	152	164	73	173	1037	259	99	173	286	166	324	115	192	1614
GAH125DP1M	143	62	161	90	161	152	71	177	1017	155	67	166	106	163	167	75	180	1079	258	108	172	262	215	313	121	207	1656
GAH140DP1M	130	62	149	108	180	137	70	162	998	152	69	160	136	190	160	74	171	1112	323	119	234	360	262	366	120	258	2042

2.- INSTALLATION

2.5.- WEIGHT DISTRIBUTION (kg)

Nr. Position	STD Unit												Total (Kg)
	1	2	3	4	5	6	7	8	9	10	11	12	
GAC160DP1M	162	113	155	112	113	98	116	61	57	86	68	75	1216
GAC185DP1M	181	128	174	125	126	109	127	66	63	90	71	80	1340
GAC210DP1M	181	128	174	125	126	109	127	66	63	90	71	80	1340
GAH160DP1M	180	126	171	127	128	113	135	72	67	101	77	91	1388
GAH185DP1M	190	134	182	135	136	119	141	75	71	105	80	95	1463
GAH210DP1M	190	134	182	135	136	119	141	75	71	105	80	95	1463

Nr. Position	With Dual Pump												Total (Kg)
	1	2	3	4	5	6	7	8	9	10	11	12	
GAC160DP1M	158	114	162	110	120	100	131	62	65	99	87	122	1330
GAC185DP1M	177	129	181	123	133	111	142	68	71	103	90	126	1454
GAC210DP1M	177	129	181	123	133	111	142	68	71	103	90	126	1454
GAH160DP1M	176	127	178	126	136	114	151	74	75	115	96	134	1502
GAH185DP1M	186	136	189	133	143	120	156	77	79	119	100	139	1577
GAH210DP1M	186	136	189	133	143	120	156	77	79	119	100	139	1577

Nr. Position	With Dual Pump & Water Tank												Total (Kg)
	1	2	3	4	5	6	7	8	9	10	11	12	
GAC160DP1M	191	133	180	144	157	155	232	125	93	310	228	312	2260
GAC185DP1M	209	148	199	155	168	163	239	127	96	320	238	322	2384
GAC210DP1M	209	148	199	155	168	163	239	127	96	320	238	322	2384
GAH160DP1M	209	146	196	159	172	169	252	136	101	327	238	327	2432
GAH185DP1M	220	155	207	167	179	176	257	139	105	331	240	331	2507
GAH210DP1M	220	155	207	167	179	176	257	139	105	331	240	331	2507

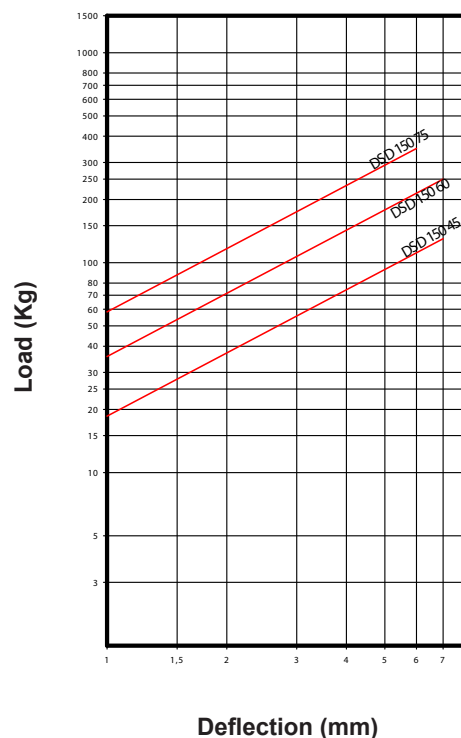
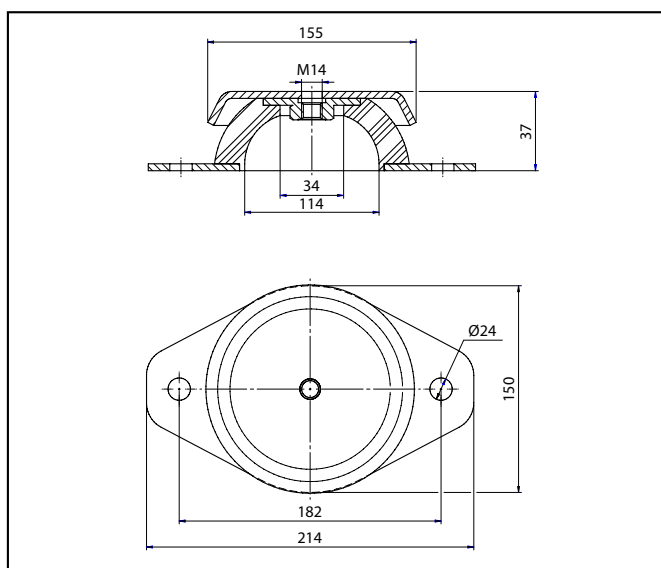
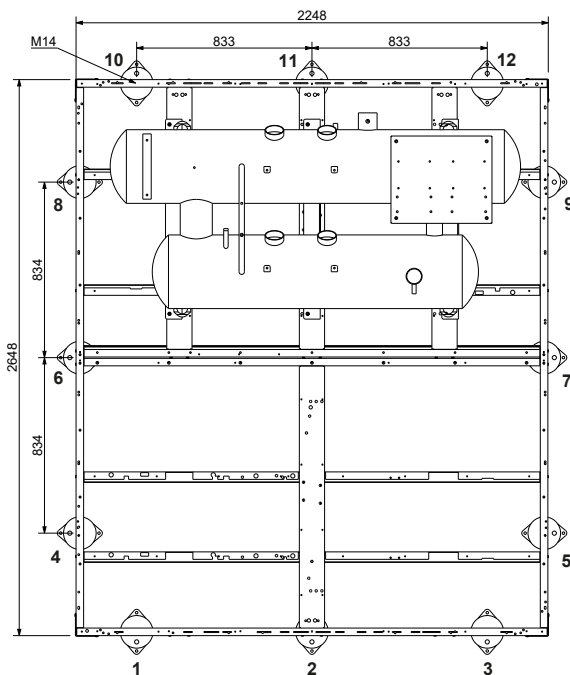

2.- INSTALLATION

2.5.- WEIGHT DISTRIBUTION (kg)

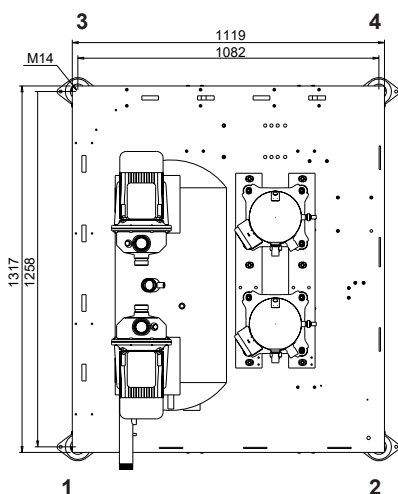

Nr. Position	STD Unit					With Dual Pump					With Dual Pump & Water Tank				
	1	2	3	4	Total (Kg)	1	2	3	4	Total (Kg)	1	2	3	4	Total (Kg)
GBC040SP1M	72	87	79	94	332	91	93	96	98	378	174	132	174	131	611
GBC060SP1M	79	92	91	105	367	98	99	107	109	413	206	157	212	161	736
GBH040SP1M	76	87	88	100	351	94	94	104	105	397	176	131	185	138	630
GBH060SP1M	84	106	93	118	401	102	109	114	122	447	209	165	222	174	770

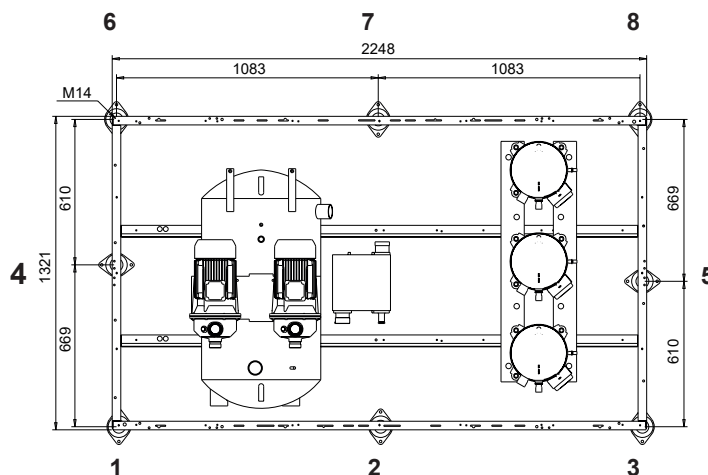

Nr. Position	STD Unit									With Dual Pump								With Dual Pump & Water Tank									
	1	2	3	4	5	6	7	8	Total (Kg)	1	2	3	4	5	6	7	8	Total (Kg)	1	2	3	4	5	6	7	8	Total (Kg)
GBC070SP1M	77	69	98	29	40	70	70	94	547	91	78	97	35	40	86	79	97	603	231	158	113	87	44	206	136	101	1076
GBC080SP1M	83	81	114	33	48	81	84	116	640	97	89	114	39	49	97	93	118	696	237	170	130	90	52	218	150	122	1169
GBC110SP1M	97	72	129	36	52	86	88	122	682	113	82	129	43	53	103	97	124	744	283	180	148	106	57	251	167	129	1321
GBC120SP1M	102	79	136	38	56	90	93	127	721	117	88	137	45	56	107	102	131	783	287	186	156	107	60	255	172	137	1360
GBH070SP1M	81	77	108	32	45	78	80	108	609	95	85	107	38	45	94	89	112	665	235	166	123	89	49	215	146	115	1138
GBH080SP1M	87	89	125	36	54	90	95	129	705	101	97	125	42	54	106	103	133	761	241	178	140	93	58	227	161	136	1234
GBH110SP1M	101	78	137	40	57	98	99	136	746	117	87	136	47	57	115	109	140	808	287	185	155	110	62	263	179	144	1385
GBH115SP1M	106	85	146	41	61	101	105	144	789	122	95	146	48	61	119	114	146	851	292	193	164	111	65	266	184	153	1428

2.- INSTALLATION

2.5.- WEIGHT DISTRIBUTION (kg)

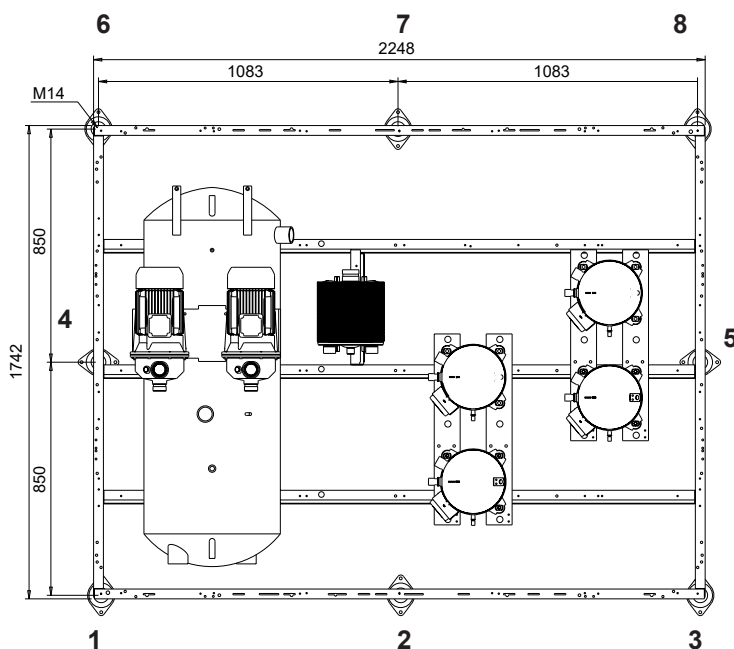

Nr. Position	STD Unit									With Dual Pump								With Dual Pump & Water Tank									
	1	2	3	4	5	6	7	8	Total (Kg)	1	2	3	4	5	6	7	8	Total (Kg)	1	2	3	4	5	6	7	8	Total (Kg)
GBC125DP1M	127	67	145	92	150	113	67	133	894	138	68	144	110	153	132	73	138	956	251	108	152	267	173	287	119	176	1533
GBC140DP1M	139	73	159	97	163	113	67	138	949	150	74	158	114	166	132	73	144	1011	263	114	166	271	186	288	119	181	1588
GBH125DP1M	137	72	157	110	176	127	74	148	1001	148	72	156	128	178	146	81	154	1063	261	113	164	284	199	302	127	190	1640
GBH140DP1M	149	78	171	116	191	129	76	155	1065	160	79	170	134	194	148	82	160	1127	273	120	178	289	214	304	128	198	1704

2.- INSTALLATION

2.6.- INSTALLATION CLEARANCES

Clearance around the unit, for any unit version. Keep this space free around the unit for installation. Failure to install the units as shown will impact performance and reliability.

STANDARD VERSION OR WITH HIGH PRESSURE EC FANS (HIPF)

UNIT WITH OPTIONAL AC FANS (SFAC)

GAC/H 035S-040S-045S

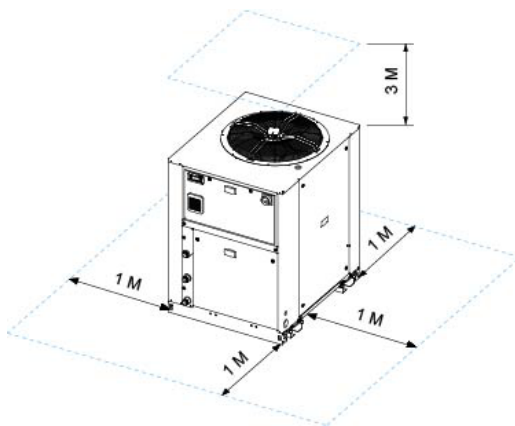
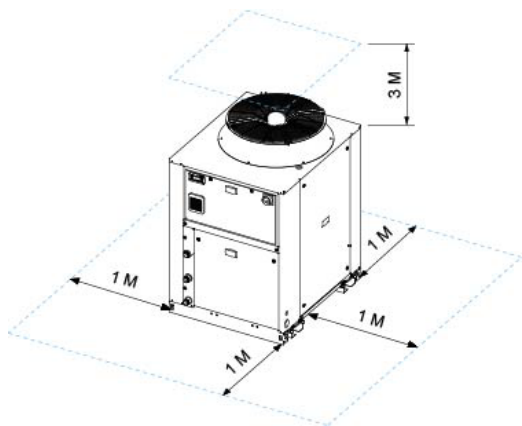

GAC/H 050S-055S-060S

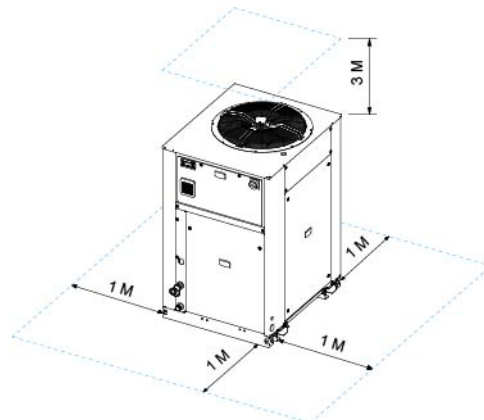
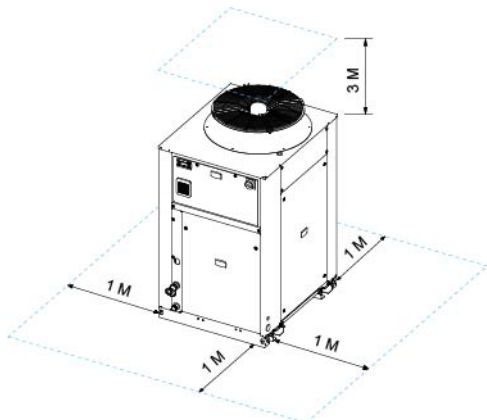

GAC/H 065S-070S

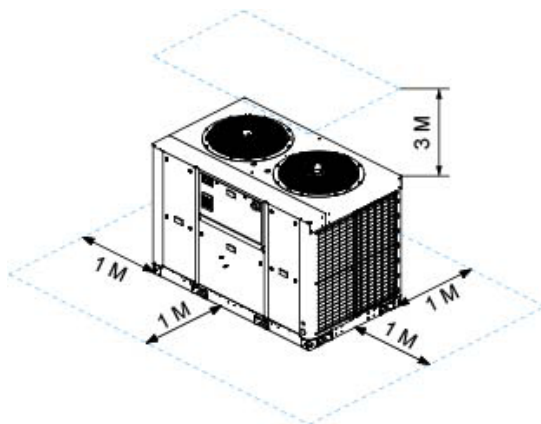
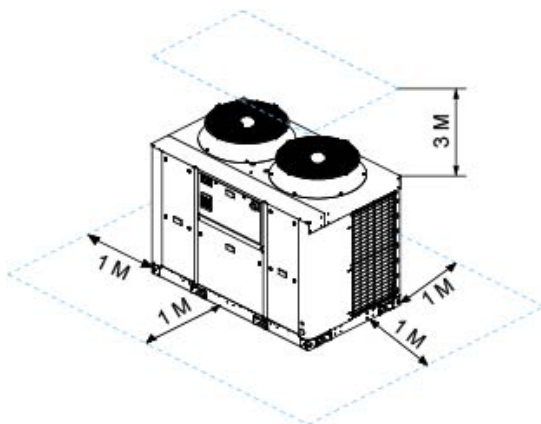

2.- INSTALLATION

2.6.- INSTALLATION CLEARANCES

STANDARD VERSION OR WITH HIGH PRESSURE EC FANS (HIPF)

UNIT WITH OPTIONAL AC FANS (SFAC)

GAC/H 080S

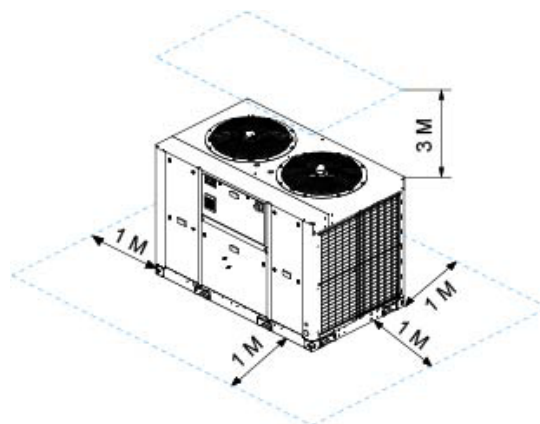
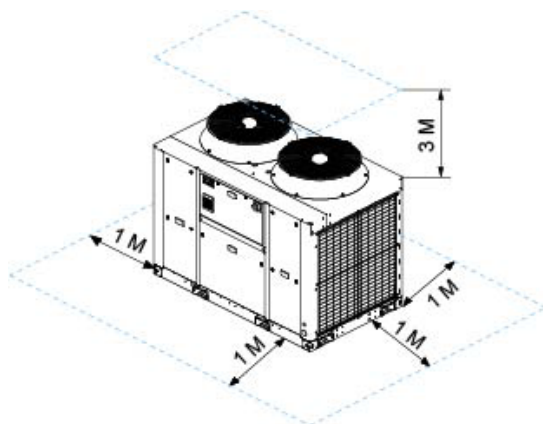

GAC/H 095S-110S-115S

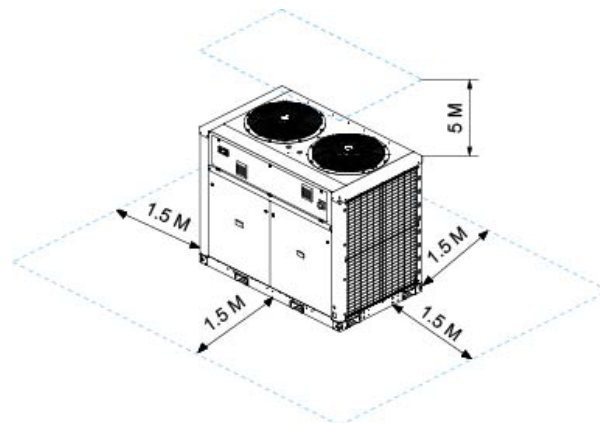
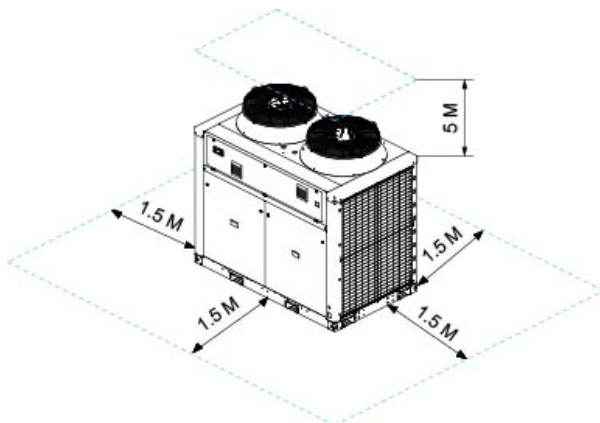

**GAC/H 125S-140S
GAC/H 110D-125D-140D**

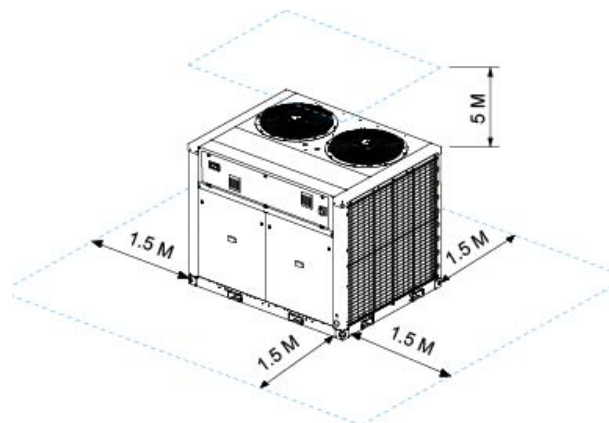
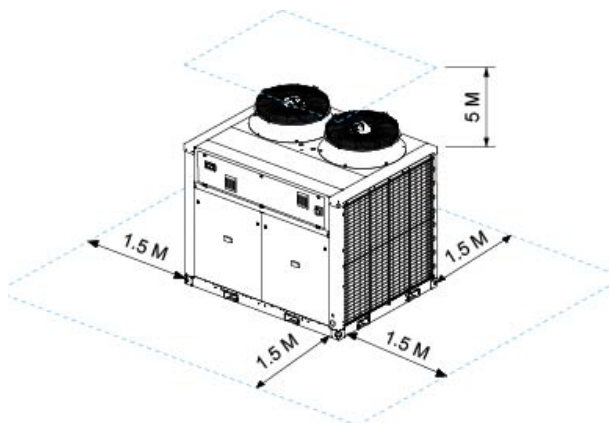

GAC/H 160D-185D-210D

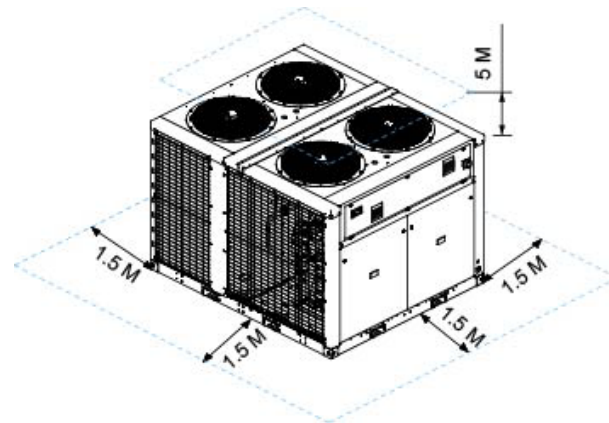
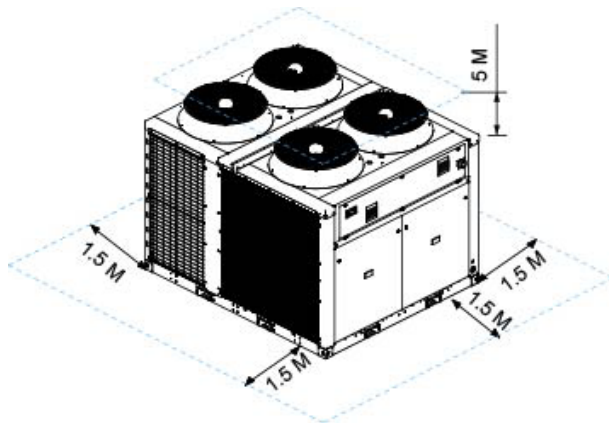

2.- INSTALLATION

2.6.- INSTALLATION CLEARANCES

STANDARD VERSION OR WITH HIGH PRESSURE EC FANS (HIPF)

GBC/H 040S

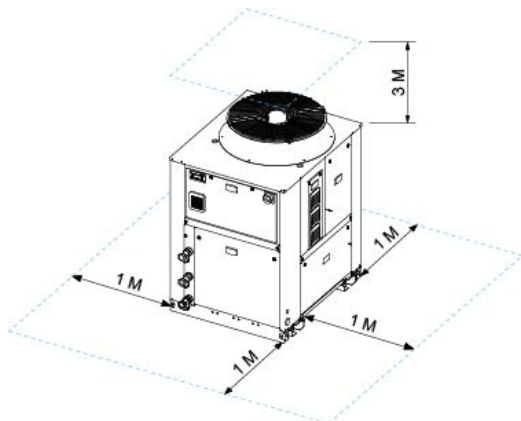

GBC/H 060S

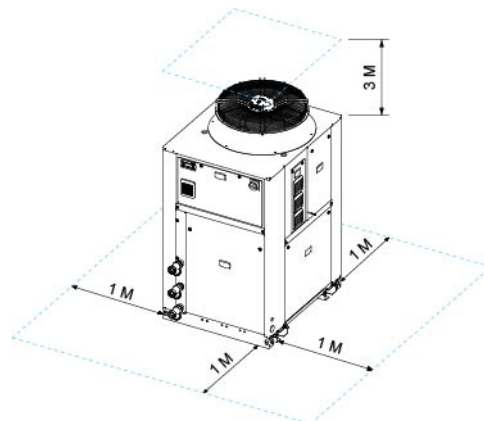

GBC/H 070S

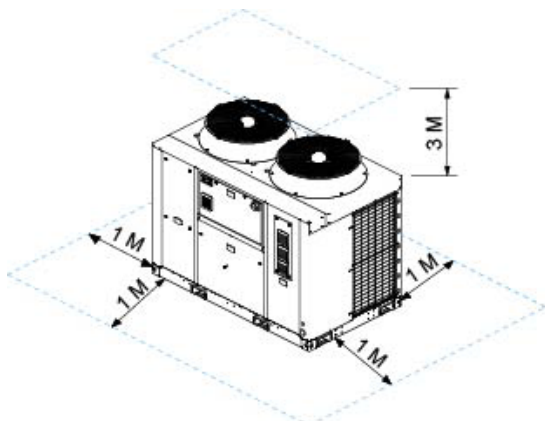

GBC/H 080S

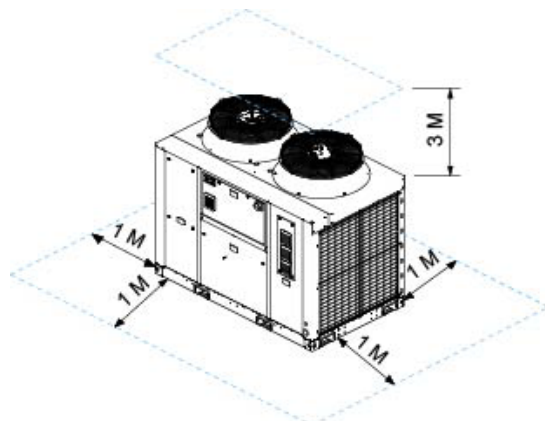

GBC/H 110S-120S

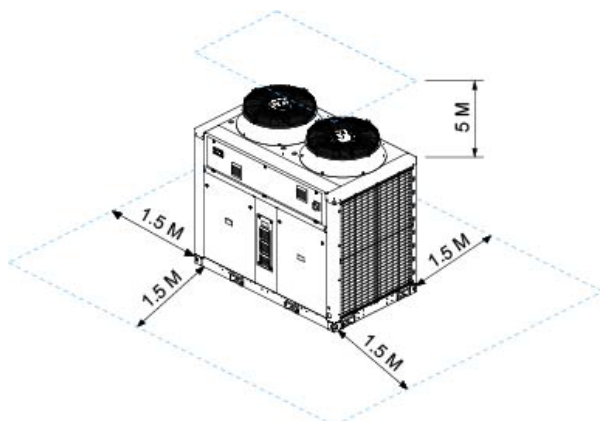

GBC/H 125D-140D

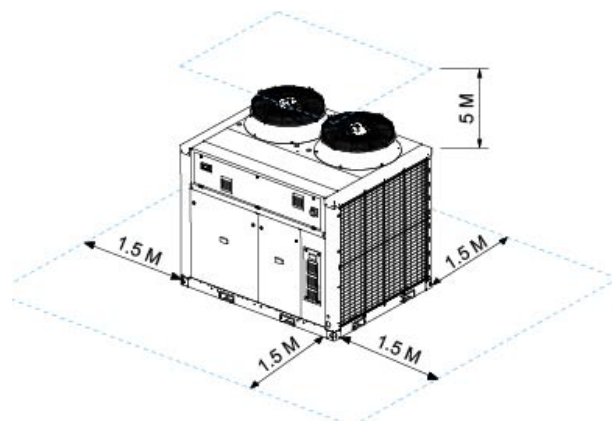

GBC/H 160D-185D-210D

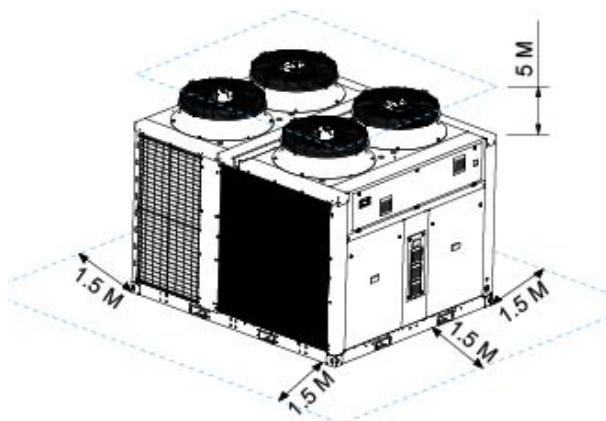

2.- INSTALLATION

2.7.- UNIT INSTALLATION

1. The eComfort R32 units could be installed outside or inside.
2. See the minimum clearance diagrams for access - air supply to the batteries in the heating section of the unit.
3. Assemble the unit on a solid and resistant base, preferably concrete. To prevent vibrations, the concrete base should not come into contact with the building's foundations.
4. It is advisable to assemble the unit on shock absorbers (antivibration mountings).
5. During heating mode (heating pump coolers) ice forms in the coils. The defrost process is activated during heating mode in heat pump units, when the outside temperature is low and the outdoor coil could become frozen. To melt the ice, the defrost function will switch the unit to cooling operation for a short period. When the evaporation temperature starts to drop, a defrost period sets in to provide sufficient heat transfer. During defrosting, the ice melts from the batteries. As a result, the ice contains water which must be removed.



WARNING

If the unit is exposed for long periods to installation conditions below 0°C the water from defrost can freeze in the base of the unit. This prevents drainage. Ice build up can occur preventing correct operation. For these conditions contact customer service team.

6. The heat exchanger water flow during cooling must be the same as during heating.
7. The use of a water filter in the water circuit upstream of the heat exchanger is mandatory. These filters must remove all particles with a diameter greater than 1 mm, and must be positioned within 1 meter of the inlet of the exchanger. They may be supplied as an option by the manufacturer.



LACK OF FILTER AT THE INLET OF A PLATE HEAT EXCHANGER WILL MAKE WARRANTY VOID.

It is important to follow non exhaustive recommendations hereunder:

- The water pipes must not transmit any radial or axial force to the heat exchangers nor any vibration (Use flexible connections to reduce the transmission of vibrations).
- Manual or automatic air bleeders must be installed at all high points in the circuit(s).
- Drain connections must be installed at all low points to allow the whole circuit to be drained.
- An expansion device must be installed to maintain pressure in the circuit(s) as well as a safety device
- Comply with the water inlet and outlet connections shown on the unit.
- Install thermometers in both the entering and leaving water connections.
- Install stop valves, close to the entering and leaving water connections.
- After testing for leaks, insulate all pipe work, to reduce thermal leaks and to prevent condensation.
- If the external water pipes are in an area, where the ambient temperature is likely to fall below 0°C, insulate the piping and add an electric heater. As an option, the internal unit piping is protected.
- Ensure full earthing continuity
- Connection pipes must under no circumstances generate strain on the piping system of our units. To do this, appropriate means of support and fastening must be used.
- Respect a sufficient number of supports for the piping according to their size and weight under operating conditions and to design the piping to avoid a water hammer phenomenon.

8. Use water treating if necessary.

9. Location inside:

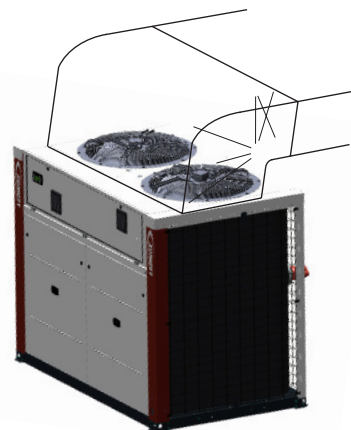
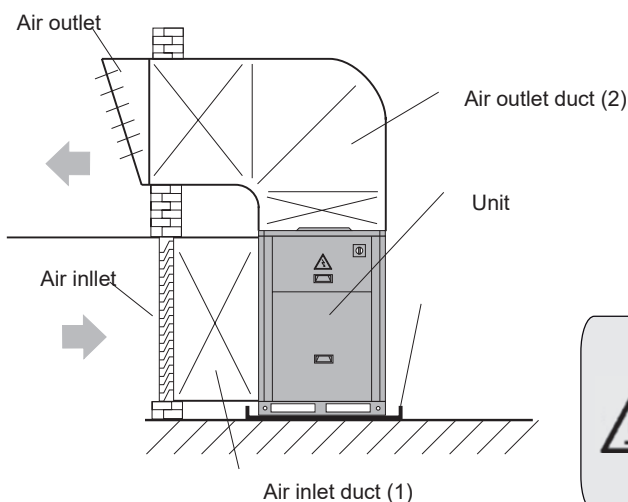

WARNING: These units use semi-flammable refrigerants and must be executed correctly while observing safety rules, as specified in corresponding safety standards such as, but not limited to EN 378. They must comply with any and all applicable legislation and regulations. Ensuring compliance remains the user's responsibility.

2.- INSTALLATION

For location inside, keep in mind following advice:

- In heat pump units during defrost cycle, the units produce a great amount of water melting the ice off coils. If you wish to drain the water, adequate drainage should be installed below the unit to collect and carry out the water where desired.
- Air duct installation:

If the air duct has been installed, the operating limits get reduced.

10. For cooling or heat pump units the hydraulic system must contain the following components pump, buffer tank, expansion device, safety valve, water filter, flow switch.
11. To obtain the total water system pressure drop add the unit pressure drop + water pipework + fittings and terminal unit pressure drops the water pump can be selected to provide the correct water flow across the heat exchanger.
12. A water balancing valve is advised to ensure correct water flow.
13. Pressure safety controls must be guaranteed and ensured:
 - The applicable regulations and standards (for example: EN 378-2) will be followed, to apply the appropriate control and guarantee that the pressure never exceeds the maximum limit.
 - High pressure protection is required to stop compressor operation outside allowable pressure limits. The high pressure control must be installed correctly, which means that no service valve is allowed between the compressor and the pressure protection.
 - The high pressure cut-out setting will be determined according to the applicable standard, the type of system, the refrigerant and the maximum allowable pressure PS.
 - Ensure that the pressure never drops below atmospheric pressure. If so, immediately disconnect the power supply to the compressor and check the cause of the low pressure before restarting the compressor.



CAUTION:

Operation outside the field of application: Compressor failure. A low pressure protection is installed on the suction line to stop the compressor when operating outside the limits of the enclosure.



WARNING:

Operation below ambient pressure. Fire danger. During operation below ambient pressure, a flammable mixture may form within the system. Make sure no air enters the system.

14. A crankcase heater is used to prevent coolant from migrating into the housing during periods of non-use. Installation of a crankcase heater is required when the system load exceeds the load limits stated by the supplier. This requirement is independent of the type and configuration of the system.

Initial field start-up is a very critical period for any compressor because all loading surfaces are new and require a short break-in period to withstand high loads in harsh conditions. The crankcase heater must be turned on a minimum of 8 hours before the compressor is started. This will prevent oil dilution and bearing stress on initial start-up. The crankcase heater must remain energized during compressor off cycles and must be properly grounded.



WARNING:

Ignition source in a potentially flammable atmosphere: Fire hazard. The crankcase heater is not an ignition source during normal operation, but could become one if not installed correctly in accordance with the installation instructions. Ensure correct electrical and mechanical installation.

15. It is recommended to operate fixed speed scroll compressors with soft-starters. The versions and sizes of the soft-starters must be selected according to the manufacturer's recommendations, taking into account the amps of the compressor. Due to the design of the compressors, the internal compression components start unloaded, even if the system pressures are not balanced. Since the internal pressures of the compressor are balanced at startup, low voltage starting characteristics are excellent and starting components are not normally required.

16. Good system control should prevent the system from operating outside the published operating range and acceptable superheat range, regardless of weather conditions and capacity demand. However, under some extreme operating conditions, such as loss of load or improper control operation, the internal discharge gas temperature reached may damage the compressor. To ensure positive compressor protection, discharge gas temperature protection is required for any application with these compressors.



CAUTION:

Inadequate lubrication: Damage to the scroll assembly. All compressors are equipped with external discharge gas temperature protection.

2.- INSTALLATION

17. Oil circulation through the system must be ensured at all times (compressor oil return, oil balance, refrigerant reflux and oil dilution). The pipes of the refrigeration system have been designed to guarantee a sufficient velocity of the refrigerant gas, so that the oil returns to the compressor at all times and in all conditions. The calculation of the diameter of the individual pipes depends on the properties of the refrigerant, the pressure level, the mass flow rate and the density.

CAUTION:



Inadequate lubrication: Destruction of bearings and moving parts. Ensure that oil return from the system to the compressor is adequate at all times. There is no return of liquid refrigerant to the compressor. Liquid refrigerant dilutes oil, could wash oil from bearings and moving parts, and could cause overheating and compressor failure.



IMPORTANT

If the outside temperature in the area where the eComfort R32 unit is to be installed is likely to drop below 5°C, it is very important to take the following precautions to avoid that water in the circuit freezing, that may produce damage to the components.

- If unit has to work under low outside temperatures:

* Do not disconnect power supply in order that water pump starts when detects water temperatures below +5 °C (only Hydraulic and Hydronic models).

* If the outside temperature where the system is to be installed or the water outlet temperature is likely to drop below 5°C, it is very important to use glycol anti-freeze.

The amount of anti-freeze required will vary depending on the minimum ambient temperature or the water outlet temperature.

When the percentage of glycol increases the standard pump flow decreases, the pressure drop increases and the cooling and thermal capacities drop. As a result the minimum flow must be multiplied by the coefficient shown in the table:

Minimum ambient temperature or water outlet temperature	Ethylene Glycol %	Pressure drop	Water flow	Power input	Capacities	
					Cooling mode	Heating mode
From +5°C to 0°C	10%	1,05	1,02	0,997	0,995	0,994
From 0°C to -5°C	20%	1,10	1,05	0,996	0,985	0,993
From -5°C to -10°C	30%	1,15	1,08	0,995	0,975	0,99
From -10°C to -15°C	35%	1,18	1,10	0,994	0,965	0,987

Also is advisable to use the option “evaporator anti freeze protection”

Failure to follow this advice, may result in damage to the installation.

Optionally, an immersion heater can be supplied complete with safety thermostat and pressure switch fitted in the buffer tank of the cooling only chiller. A similar option is available for heat pump versions with the added advantage of a supplementary heating source (Hydronic version units).



Legislation does not allow refrigerant gas emissions to the atmosphere, so the refrigerants have to be recycled to avoid being released to the atmosphere.

Those recycled refrigerants shall be processed afterwards by an authorized waste manager. Those components derived from the recycling of the unit have to be managed by authorized waste manager or be left in local waste facilities according the local normative in each country.

2.- INSTALLATION

2.8.- ELECTRICAL CONNECTIONS

For safety reasons, LENNOX recommends that the electrical installation be carried out in accordance with EN 60204-1 and/or other applicable Standards and Regulations when dealing with slightly flammable A2L refrigerants.



- BEFORE MAKING ANY ELECTRICAL CONNECTIONS, BE SURE THAT ALL CIRCUIT BREAKERS ARE OPEN AND SUPPLY IS OFF.
- IN ORDER TO CARRY OUT THE ELECTRICAL CONNECTIONS, FOLLOW THE ELECTRICAL DIAGRAM SUPPLIED WITH THE UNIT.
- TAKE INTO ACCOUNT THE CURRENT STANDARD FOR THE INSTALLATION OF THE UNIT, WHETHER LOCAL, REGIONAL OR NATIONAL STANDARDS.
- **USE SUPERINMUNIZED DIFFERENTIAL SWITCHES.**



WARNING:

Ignition source in a potentially flammable atmosphere: Fire hazard. Electrical connections are not an ignition source during normal operation, but could become one if not installed correctly according to installation instructions. Ensure correct mechanical and electrical installation.



Before connecting the electric power cables (L1 - L2 - L3), it is imperative to check the correct order of the 3 phases before connecting to the main disconnect switch.

Use proper wire terminal material that is compatible to the type of wire (Copper or Aluminum) being used.

Use proper procedures and coatings when using aluminum wires to avoid galvanic corrosion which may lead to a short circuit event.



WARNING:

Electrostatic discharge (ESD): Damage to the communication module. When connecting the wires to the terminal box, be sure to use an antistatic device (for example: antistatic wrist straps) or apply sufficient ESD protection (for example: electrical grounding), as electrostatic discharge can damage electronic components, communication module.

Recommended cable selection

The sizing of the power cables is the responsibility of the installer. It must be done in accordance with the electrical values of each unit (noted at the time of ordering, the firm plate and on the electric diagram) and according to the **regulations of each country**.

The table below is given as an indication and does not engage the responsibility of LENNOX.

Once the selection is made, the installer must make the adaptations if necessary.

The connections on the main switch of the unit are to be realized with lugs or bars. In case of use of aluminum wires, the customer must use bi-metal terminals.

- WTHH: Water tank electrical heater.
- The cable sections have been calculated based on.
 - A distance of 50m and variation of -10V.
 - XLPE insulation copper cable over perforated cable tray.
 - Max. T^a: 50°C.
 - Type of cable in Cu RV-K.
- Do not start the unit if the drop is greater than this.
- Ground wires must be properly connected and have a greater length than the phase wires.

2.- INSTALLATION

2.8.- ELECTRICAL CONNECTIONS

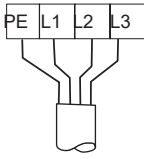
POWER SUPPLY	UNIT MODEL GAC	NUMBER OF WIRE PER SECTION			
		CUPPPER CU		ALUMINIUM AL	
		WITHOUT APPW	WITH APPW	WITHOUT APPW	WITH APPW
 <p>3 ~ 400V-50Hz + PE</p>	035SP1M	4G x 6mm ²	4G x 6mm ²	4G x 6mm ²	4G x 10mm ²
	040SP1M	4G x 6mm ²	4G x 6mm ²	4G x 6mm ²	4G x 10mm ²
	045SP1M	4G x 6mm ²	4G x 10mm ²	4G x 10mm ²	4G x 10mm ²
	050SP1M	4G x 6mm ²	4G x 10mm ²	4G x 10mm ²	4G x 16mm ²
	055SP1M	4G x 6mm ²	4G x 10mm ²	4G x 10mm ²	4G x 16mm ²
	060SP1M	4G x 10mm ²	4G x 16mm ²	4G x 16mm ²	4G x 16mm ²
	065SP1M	4G x 10mm ²	4G x 16mm ²	4G x 16mm ²	3 x 25mm ² 1 x 16mm ²
	070SP1M	4G x 10mm ²	4G x 16mm ²	4G x 16mm ²	3 x 25mm ² 1 x 16mm ²
	080SP1M	4G x 16mm ²	4G x 16mm ²	3 x 25mm ² 1 x 16mm ²	3 x 35mm ² 1 x 16mm ²
	095SP1M	4G x 16mm ²	3 x 25mm ² 1 x 16mm ²	3 x 25mm ² 1 x 16mm ²	3 x 35mm ² 1 x 16mm ²
	110SP1M	3 x 25mm ² 1 x 16mm ²	3 x 35mm ² 1 x 16mm ²	3 x 35mm ² 1 x 16mm ²	3 x 50mm ² 1 x 25mm ²
	115SP1M	3 x 25mm ² 1 x 16mm ²	3 x 35mm ² 1 x 16mm ²	3 x 35mm ² 1 x 16mm ²	3 x 50mm ² 1 x 25mm ²
	125SP1M	3 x 25mm ² 1 x 16mm ²	3 x 35mm ² 1 x 16mm ²	3 x 50mm ² 1 x 25mm ²	3 x 70mm ² 1 x 35mm ²
	140SP1M	3 x 35mm ² 1 x 16mm ²	3 x 50mm ² 1 x 25mm ²	3 x 70mm ² 1 x 35mm ²	3 x 70mm ² 1 x 35mm ²
	110DP1M	3 x 25mm ² 1 x 16mm ²	3 x 35mm ² 1 x 16mm ²	3 x 35mm ² 1 x 16mm ²	3 x 50mm ² 1 x 25mm ²
	125DP1M	3 x 25mm ² 1 x 16mm ²	3 x 35mm ² 1 x 16mm ²	3 x 50mm ² 1 x 25mm ²	3 x 70mm ² 1 x 35mm ²
	140DP1M	3 x 35mm ² 1 x 16mm ²	3 x 50mm ² 1 x 25mm ²	3 x 50mm ² 1 x 25mm ²	3 x 70mm ² 1 x 35mm ²
	160DP1M	3 x 50mm ² 1 x 25mm ²	3 x 70mm ² 1 x 35mm ²	3 x 70mm ² 1 x 35mm ²	3 x 95mm ² 1 x 50mm ²
	185DP1M	3 x 70mm ² 1 x 35mm ²	3 x 70mm ² 1 x 35mm ²	3 x 95mm ² 1 x 50mm ²	3 x 120mm ² 1 x 70mm ²
	210DP1M	3 x 70mm ² 1 x 35mm ²	3 x 95mm ² 1 x 50mm ²	3 x 95mm ² 1 x 50mm ²	3 x 120mm ² 1 x 70mm ²

2.- INSTALLATION

2.8.- ELECTRICAL CONNECTIONS

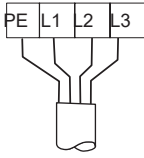
POWER SUPPLY	UNIT MODEL GAH	NUMBER OF WIRE PER SECTION			
		CUPPPER CU		ALUMINIUM AL	
		WITHOUT WTHH	WITH WTHH	WITHOUT WTHH	WITH WTHH
 <p>3 ~ 400V-50Hz + PE</p>	035SP1M	4G x 6mm ²	4G x 10mm ²	4G x 6mm ²	4G x 16mm ²
	040SP1M	4G x 6mm ²	4G x 10mm ²	4G x 6mm ²	4G x 16mm ²
	045SP1M	4G x 6mm ²	4G x 10mm ²	4G x 10mm ²	4G x 16mm ²
	050SP1M	4G x 6mm ²	4G x 16mm ²	4G x 10mm ²	3 x 35mm ² 1 x 16mm ²
	055SP1M	4G x 10mm ²	3 x 25mm ² 1 x 16mm ²	4G x 10mm ²	3 x 35mm ² 1 x 16mm ²
	060SP1M	4G x 10mm ²	3 x 25mm ² 1 x 16mm ²	4G x 16mm ²	3 x 35mm ² 1 x 16mm ²
	065SP1M	4G x 10mm ²	3 x 25mm ² 1 x 16mm ²	4G x 16mm ²	3 x 35mm ² 1 x 16mm ²
	070SP1M	4G x 10mm ²	3 x 25mm ² 1 x 16mm ²	4G x 16mm ²	3 x 50mm ² 1 x 25mm ²
	080SP1M	4G x 16mm ²	3 x 35mm ² 1 x 16mm ²	3 x 25mm ² 1 x 16mm ²	3 x 50mm ² 1 x 25mm ²
	095SP1M	4G x 16mm ²	3 x 50mm ² 1 x 25mm ²	3 x 25mm ² 1 x 16mm ²	3 x 70mm ² 1 x 35mm ²
	110SP1M	3 x 25mm ² 1 x 16mm ²	3 x 50mm ² 1 x 25mm ²	3 x 35mm ² 1 x 16mm ²	3 x 70mm ² 1 x 35mm ²
	115SP1M	3 x 25mm ² 1 x 16mm ²	3 x 70mm ² 1 x 35mm ²	3 x 35mm ² 1 x 16mm ²	3 x 95mm ² 1 x 50mm ²
	125SP1M	3 x 25mm ² 1 x 16mm ²	3 x 70mm ² 1 x 35mm ²	3 x 50mm ² 1 x 25mm ²	3 x 95mm ² 1 x 50mm ²
	140SP1M	3 x 35mm ² 1 x 16mm ²	3 x 70mm ² 1 x 35mm ²	3 x 70mm ² 1 x 35mm ²	3 x 120mm ² 1 x 70mm ²
	110DP1M	3 x 25mm ² 1 x 16mm ²	3 x 50mm ² 1 x 25mm ²	3 x 35mm ² 1 x 16mm ²	3 x 95mm ² 1 x 50mm ²
	125DP1M	3 x 25mm ² 1 x 16mm ²	3 x 70mm ² 1 x 35mm ²	3 x 50mm ² 1 x 25mm ²	3 x 95mm ² 1 x 50mm ²
	140DP1M	3 x 35mm ² 1 x 16mm ²	3 x 70mm ² 1 x 35mm ²	3 x 50mm ² 1 x 25mm ²	3 x 95mm ² 1 x 50mm ²
	160DP1M	3 x 50mm ² 1 x 25mm ²	3 x 95mm ² 1 x 50mm ²	3 x 70mm ² 1 x 35mm ²	3 x 150mm ² 1 x 95mm ²
	185DP1M	3 x 70mm ² 1 x 35mm ²	3 x 120mm ² 1 x 70mm ²	3 x 95mm ² 1 x 50mm ²	3 x 150mm ² 1 x 95mm ²
210DP1M	3 x 70mm ² 1 x 35mm ²	3 x 120mm ² 1 x 70mm ²	3 x 95mm ² 1 x 50mm ²	3 x 185mm ² 1 x 95mm ²	

2.- INSTALLATION

2.8.- ELECTRICAL CONNECTIONS

POWER SUPPLY	UNIT MODEL GBC	NUMBER OF WIRE PER SECTION			
		CUPPPER CU		ALUMINIUM AL	
		WITHOUT APPW	WITH APPW	WITHOUT APPW	WITH APPW
	040SP1M	4G x 6mm ²	4G x 6mm ²	4G x 6mm ²	4G x 10mm ²
	060SP1M	4G x 6mm ²	4G x 6mm ²	4G x 10mm ²	4G x 16mm ²
	070SP1M	4G x 10mm ²	4G x 16mm ²	4G x 16mm ²	3 x 25mm ² 1 x 16mm ²
	080SP1M	4G x 16mm ²	4G x 16mm ²	4G x 16mm ²	3 x 35mm ² 1 x 16mm ²
	110SP1M	4G x 16mm ²	3 x 25mm ² 1 x 16mm ²	3 x 25mm ² 1 x 16mm ²	3 x 35mm ² 1 x 16mm ²
	120SP1M	3 x 25mm ² 1 x 16mm ²	3 x 35mm ² 1 x 16mm ²	3 x 35mm ² 1 x 16mm ²	3 x 50mm ² 1 x 25mm ²
	125DP1M	3 x 25mm ² 1 x 16mm ²	3 x 35mm ² 1 x 16mm ²	3 x 50mm ² 1 x 25mm ²	3 x 70mm ² 1 x 35mm ²
	140DP1M	3 x 35mm ² 1 x 16mm ²	3 x 50mm ² 1 x 25mm ²	3 x 70mm ² 1 x 35mm ²	3 x 70mm ² 1 x 35mm ²
	160DP1M	3 x 35mm ² 1 x 16mm ²	3 x 70mm ² 1 x 35mm ²	3 x 70mm ² 1 x 35mm ²	3 x 95mm ² 1 x 50mm ²
	185DP1M	3 x 50mm ² 1 x 25mm ²	3 x 70mm ² 1 x 35mm ²	3 x 70mm ² 1 x 35mm ²	3 x 95mm ² 1 x 50mm ²
	210DP1M	3 x 70mm ² 1 x 35mm ²	3 x 70mm ² 1 x 35mm ²	3 x 95mm ² 1 x 50mm ²	3 x 120mm ² 1 x 70mm ²

POWER SUPPLY	UNIT MODEL GBH	NUMBER OF WIRE PER SECTION			
		CUPPPER CU		ALUMINIUM AL	
		WITHOUT WTHH	WITH WTHH	WITHOUT WTHH	WITH WTHH
	040SP1M	4G x 6mm ²	4G x 10mm ²	4G x 6mm ²	4G x 16mm ²
	060SP1M	4G x 6mm ²	3 x 25mm ² 1 x 16mm ²	4G x 10mm ²	3 x 25mm ² 1 x 16mm ²
	070SP1M	4G x 10mm ²	3 x 25mm ² 1 x 16mm ²	4G x 16mm ²	3 x 35mm ² 1 x 16mm ²
	080SP1M	4G x 16mm ²	3 x 35mm ² 1 x 16mm ²	4G x 16mm ²	3 x 50mm ² 1 x 25mm ²
	110SP1M	4G x 16mm ²	3 x 50mm ² 1 x 25mm ²	3 x 25mm ² 1 x 16mm ²	3 x 70mm ² 1 x 35mm ²
	120SP1M	3 x 25mm ² 1 x 16mm ²	3 x 70mm ² 1 x 35mm ²	3 x 35mm ² 1 x 16mm ²	3 x 95mm ² 1 x 50mm ²
	125DP1M	3 x 25mm ² 1 x 16mm ²	3 x 70mm ² 1 x 35mm ²	3 x 50mm ² 1 x 25mm ²	3 x 95mm ² 1 x 50mm ²
	140DP1M	3 x 35mm ² 1 x 16mm ²	3 x 70mm ² 1 x 35mm ²	3 x 70mm ² 1 x 35mm ²	3 x 95mm ² 1 x 50mm ²
	160DP1M	3 x 35mm ² 1 x 16mm ²	3 x 95mm ² 1 x 50mm ²	3 x 70mm ² 1 x 35mm ²	3 x 150mm ² 1 x 95mm ²
	185DP1M	3 x 50mm ² 1 x 25mm ²	3 x 95mm ² 1 x 50mm ²	3 x 70mm ² 1 x 35mm ²	3 x 150mm ² 1 x 95mm ²
	210DP1M	3 x 70mm ² 1 x 35mm ²	3 x 120mm ² 1 x 70mm ²	3 x 95mm ² 1 x 50mm ²	3 x 185mm ² 1 x 95mm ²

2.- INSTALLATION

2.8.- ELECTRICAL CONNECTIONS

VOLTAGE OPERATION LIMITS

MODELS	VOLTAGE	LIMITS
GAC/GAH 035-210 GBC/GBH 040-210	3~400V-50Hz $\pm 5\%$	3~360-440V-50Hz

Main switch pad dimension

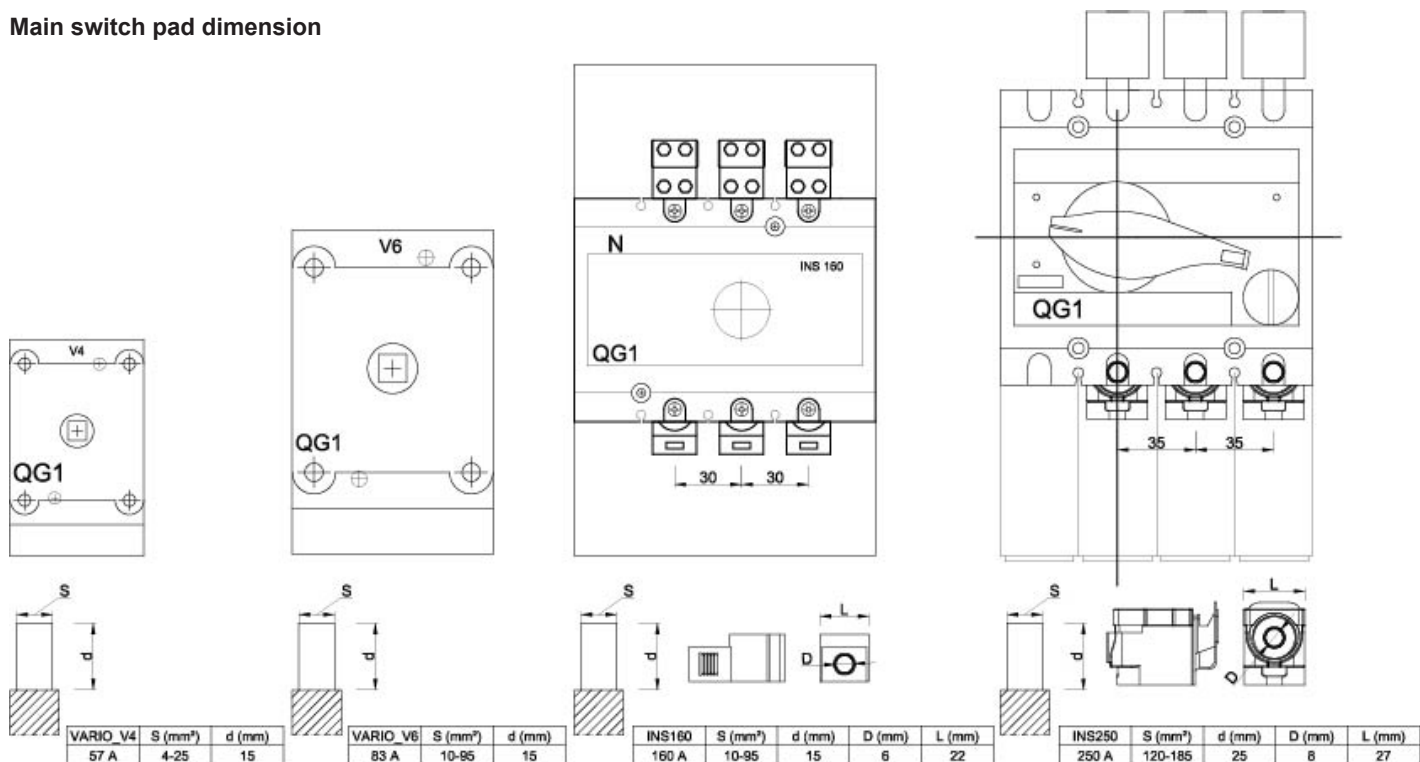

2.- INSTALLATION

2.8.- ELECTRICAL CONNECTIONS

Customer protection information

In order to protect our unit, LENNOX recommends the implementation of this type of protection upstream. There are two options available, either circuit breaker protection or fuse protection.

The customer must provide the necessary equipment in his installation to protect the power line that feeds our unit.

A differential of 300mA is recommended.

If the unit is equipped with variable condenser fans or variable speed pumps or compressor, a type B differential is recommended.

BASIC UNITS:

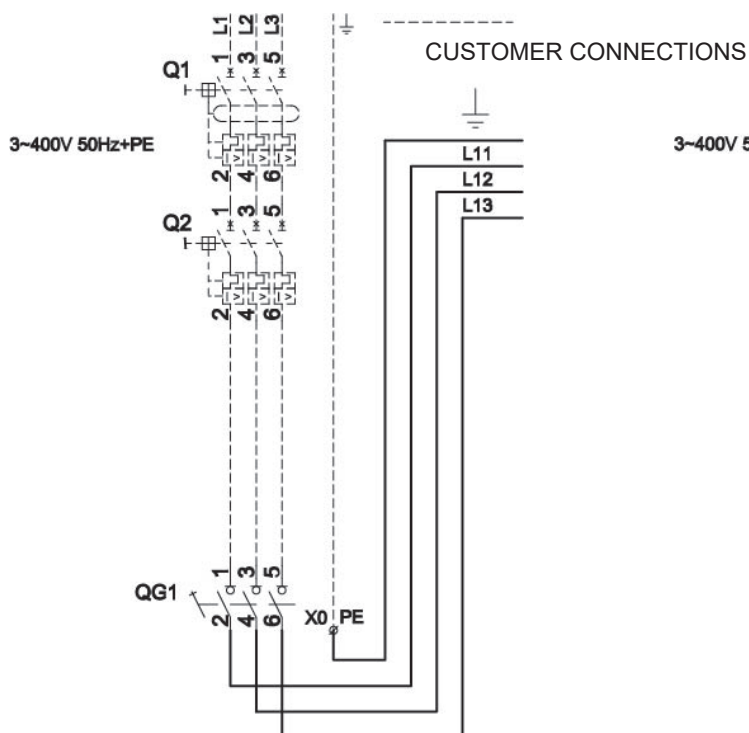

HIGH TIER:

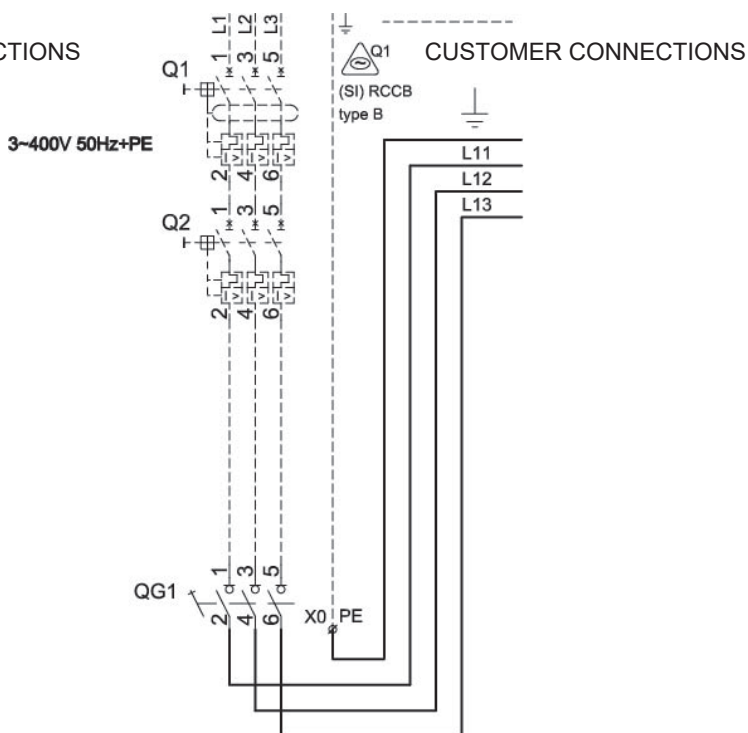

WARNING:

Ignition source in a potentially flammable atmosphere: Fire hazard. Any work on the energized terminals in the unit terminal box could create an ignition. Do not touch the energized terminals with a tool or cable when the unit is energized. Circuits operating with flammable refrigerants shall use only the qualified terminal box supplied by the Lennox.

Wiring of remote elements

- Avoid electromagnetic interference around the cables of remote elements.
- Do not run power or lighting cables and control cables in the same cable tray (minimum 50cm separation).
- Keep cables apart when they cross.
- The lengths given below are indicative and depend on the environment in which it is located:

REFERENCE	LENGTH MAX.	CONNECTION TYPE	CABLE TYPE
AD0	50m	Phone cable (RJ12)	Flat phone cable 0,25mm ² (Shielded)
AD2	500m		Li-2YCY 1x2x0,5 ou Li-2YCY 1x2x0,34 (Shielded, twisted)
AD3	50m	Phone cable (RJ12)	Flat phone cable 0,25mm ² (Shielded)
pLan, Bus	500m		Li-2YCY 1x2x0,5 ou Li-2YCY 1x2x0,34 (Shielded, twisted)
BS0 ,BH10 , BH15	200m		Li-YCY 2x0,75 ou Li-YCY 2x1 (Shielded)

2.- INSTALLATION

2.9.- OPTION: PARTIAL HEAT RECOVERY

The aim of the Partial Heat Recovery (PHRF) is to recover temperature heat from the compressor discharge gases by means of a condensing water heat exchanger.

The heat recovery capacity depends on the operating conditions (the compressor discharge temperature comes from the HP/LP ratio), on the number of compressor running, on the water flow and on the water inlet temperature.

The unit will always be driven by the air conditioning load. In any case, if there is no load on the cooling side, the unit will not be able to generate heat. The heat capacity will always be in accordance with the cooling capacity and the absorbed power of the unit.

The simplest regulation we recommend: a 3-way valve with a regulation on the water temperature. All regulation should be managed by the customer.

GAC-H 095S-110S-115S-125S-140S GBC-H 110S-120S

CUSTOMER CONNECTION

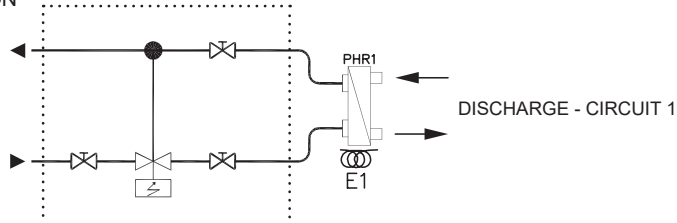

GAC-H 110D-125D-140D-160D-185D-210D GBC-H 125D-140D-160D-185D-210D

CUSTOMER CONNECTION

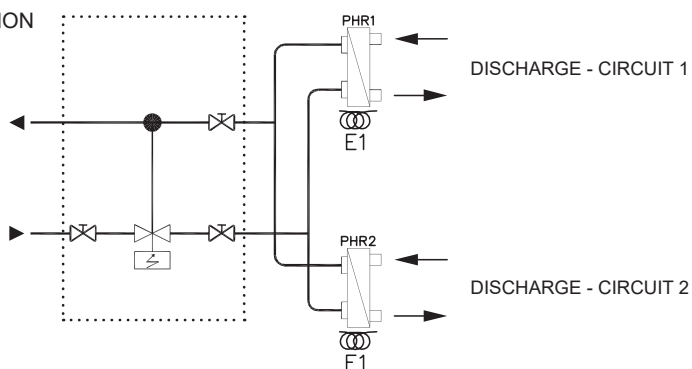

3.- COMMISSIONING AND OPERATION

LENNOX REFAC, S.A. Designs and develops its machines always looking for the greater comfort and well-being of its customers and users, at the same time as the greater energy efficiency of the elements that constitute the units. This effort would be fruitless if it was not united to a responsible use of these equipment. For this reason, we invite you to use these machines in a responsible way with the environment, combining the adequate comfort, with a responsible consumption of the energy resources.



WARNING: Diesel Effect: System explosion. The mixture of air and oil at high temperature can lead to an explosion. Avoid operating with air.



WARNING: Air mixture - R32 refrigerant in a potentially flammable atmosphere: Fire hazard. Make sure that the atmosphere is non-flammable before starting a unit charged with R32 refrigerant (eg after filling, repair or maintenance) and that the system contains only refrigerant.



IMPORTANT: Oil dilution: bearing malfunction. It is important to ensure that new compressors are not subject to fluid abuse. It is mandatory to have a crankcase heater installed if the refrigerant charge exceeds the charge limits indicated in the supplier's tables. It is recommended to turn on the crankcase heater 12 hours before starting the compressor.

3.1.- STEPS TO FOLLOW FOR COMMISSIONING THE UNITS

PRELIMINARY CHECKING

Before starting up the unit, the following points should be checked:

- 1.- Check that the voltage coincides with that indicated on the characteristics plate.
- 2.- Check that the wired remote control is connected according to the electrical diagram (if it is included).
- 3.- Make sure that the water connections to the unit (inlet and outlet) are correct and have not been changed, since the flow switch will not work if the connections are exchanged. Check that the water circuits are connected to the heat exchangers (eg no reversal between evaporator and condenser or between water inlets and outlets). The water circulation pump will preferably be installed upstream so that the evaporator / condenser is subjected to positive pressure. Input and output connections are indicated on the certified drawing shipped with the unit or shown in the catalogue. The use of a filter in the water circuit located upstream of the heat exchanger is mandatory. These filters must remove all particles with a diameter greater than 1 mm and must be placed a maximum of 1 meter from the exchanger inlet.
- 4.- Check that the main switch is "ON".
- 5.- The compressor must not be started before the crankcase heater has acted for at least 8 hours.
 - It incorporates an electrical resistance, to ensure the separation between the refrigerant fluid and the oil in the crankcase, which works when the compressor stops and stops working when the compressor starts.
 - About eight hours before starting up or after a prolonged stoppage of the unit, you must power up the unit and turn the switch ON for said resistance to act.
 - The compressor starts some time after the water pump has been started.
- 6.- Check the direction of rotation of the water pump.
- 7.- Check if there is air in the water circuit. Purge if necessary.
- 8.- Check that the fan rotates freely.
- 9.- Ensure the tightness in the refrigeration circuit.



WARNING: High pressure: Personal injury. Consider personal safety requirements and check test pressures prior to testing. Use only dry inert gases (for example: nitrogen) for leak testing. Do not use other industrial gases and never add refrigerant to the test gas (as a leak indicator).

- 10.- Specify the details of the installation with the installer, verifying:
 - Absence of explosive atmosphere or flammable gas in the environment.
 - Adequate ventilation according to the volume of the room and the refrigerant charge.
 - Visual control of electricity (wiring, fuses,...).
 - Cable glands in good condition, all electrical connections well connected and terminal box closed to guarantee the corresponding IP protection.
 - Visual inspection of the unit in search of leaks, components and loose cables in the electrical installation,...
 - Functional test of high and low pressure switches and any pressure actuated valves.
 - Setting and operation of all safety functions and protection devices.
 - Valves in the correct operating position.
 - Pressure gauges and compounds installed.
 - Correct charge with refrigerant.
 - Location and position of the electrical auxiliary switch of the compressor.

3.- COMMISSIONING AND OPERATION

3.1.- STEPS TO FOLLOW FOR COMMISSIONING THE UNITS

11.- In case it is necessary to charge the unit with refrigerant, the following recommendations must be followed:

- Before charging or recharging, the system must be leak tested and pressure tested with the appropriate purge gas.
- Make sure that the refrigerant circuit is grounded before loading it with refrigerant.
- The system will be charged with liquid through the liquid receiver shutoff valve or through a valve in the liquid line. The use of a filter drier in the charging line is strongly recommended. Since scroll compressors have discharge check valves, the systems will be charged with liquid on the high and low sides simultaneously to ensure there is positive refrigerant pressure in the compressor before it runs.
- Extreme care must be taken not to overfill the system with refrigerant. The manufacturer / installer of the system must respect the load limitations according to current standards, such as EN 378-2.



WARNING: Air/refrigerant mixture R32 in a potentially flammable atmosphere: Fire hazard. Use only filling equipment designed and approved for use and operation with A2L refrigerant. Make sure all connections are tight to prevent leaks and fill with pure A2L refrigerant.

12.- In the event that it is necessary to empty the refrigerant unit, the recommendations described above must be followed.



WARNING: Vacuum operation: Fire hazard. During vacuum operation, a flammable atmosphere can form inside the system. Extreme attention must be paid to the tightness of the system. Prevent ambient air from entering the system.



CAUTION: Vacuum operation: Damage to the compressor. Compressor operation outside the operating range is not allowed.

Always check before starting the unit that the three-phase compressor rotates correctly by means of a phase detector. Scroll type compressors only compress in one direction of rotation. It is essential that the connection of phases in three-phase compressors, SCROLL type, is carried out properly (it is verified that the direction of rotation is correct when the suction pressure decreases and the discharge pressure increases when the compressor is activated. If the connection is incorrect, rotation will be reversed, causing a high noise level and reduced current consumption, and if this occurs, the internal protection of the compressor will be activated, stopping it; this is solved by disconnecting and reconnecting, exchanging the connection of two of the three phases).



REMEMBER THAT THE COMPRESSOR IS A SCROLL TYPE COMPRESSOR

COMMISSIONING

Once the above points have been verified, the unit can be started up taking into account the following points:

- 1.- Adjust the control for the desired operating mode of the unit.
- 2.- Check the perfect operation of the compressor.
 - These compressors will only compress in one direction of rotation. Observing that the suction pressure drops and the discharge pressure rises when the compressor is energized allows verification of the proper direction of rotation.
 - Occasionally, during starts and stops, a characteristic metallic noise is produced when the compressor spirals come into contact.
 - When shutdown occurs, scroll compressors incorporate a device that minimizes reverse rotation. Residual momentary reversal of the rolls at power off could cause a clicking sound. It is completely normal and has no effect on your durability.
- 3.- Check the oil level in the compressor, if it includes a sight glass, (when the compressor stops, the level must be between 1/4 and 3/4 of the sight glass, while during operation, the level must be between 3/4 and full viewfinder). If you have to add oil, remember that it must be compatible with the one included in the compressor ((ICI EMKARATE RL32-3MAF).).
- 4.- Check that the operating pressure values are normal.
- 5.- Measure the electrical consumption of the unit.
- 6.- Check the electrical consumption of the compressor and the fans as specified in this manual.
- 7.- If the unit is a Heat Pump, change the cycle, checking that the 4-way valve makes the change correctly. It is recommended to check pressures in the new cycle.

3.- COMMISSIONING AND OPERATION

3.2.- UNIT OPERATION: REFRIGERATION CIRCUIT

OIL CHARGE:

All units are delivered with a complete oil charge, and there is no need to add any oil before start up or afterwards. When a compressor is replaced, it may be necessary to add a certain amount of oil. Oil level must be between one third and two third of the sight glass of compressor when unit is idle for 30 min. Overcharging with oil can cause serious problems on an installation, particularly for the compressors.

OIL RECOMENDATION		
Refrigerant	Compressor type	Oil type
R32	Scroll	4MA POE R32

3.3.- UNIT OPERATION: ELECTRICAL AND CONTROL FEATURES

See the specific manual for the «CLIMATIC» control.

1.- Fan over current protection:

Circuit breaker designed to stop the fan motors in the event of phase over current in relation to the permitted value.

2.- Compressor motor over current protection:

Circuit breaker designed to protect each motor winding against accidental over current.

3.- Chilled liquid pump interlock:

This interlock is made only if the the pump is supplied with the liquid chiller. As soon as the unit is powered up and the remote on/off for the unit is validated, the pump starts running. Prior operation of the pumps is mandatory for compressor operation.

Note: on units with CLIMATIC control, control of 1 or 2 water pumps is catered for by the control program.

4.- Flow switch for the chilled liquid:

This control device initiates unconditional unit stoppage as soon as the flow of chilled liquid (water, brine, etc...) ensured by the pump becomes insufficient, since this could cause rapid evaporator freeze up. When the contact opens due to a lack of flow the unit must stop immediately.

If the purchaser installs a flow switch himself, electrical connections should be made to the two remote interlock terminals (dry contact).

5.- Antifreeze protection (standard):

This feature is provided as standard by the climatic controller: and can be adjusted for brine or glycol/water chilling for which the freezing temperature depends on the concentration of the solution.

The antifreeze protection causes an immediate shut down of the unit.

The controller monitors the chilled water outlet temperature. It then triggers the fault if the temperature goes below the set point value (+3°C for water).

6.- Loss of power supply:

There are no problems restarting the machine after a loss of power supply of short duration (up to about one hour). If loss of power supply lasts longer than this, when power supply is resumed set the unit to «OFF» with the compressor crankcase heaters activated for as long as it takes to bring sump oil back up to temperature, then restart the unit.

3.4.- CLIMATIC CONTROL

See the specific manual for the «CLIMATIC» control.

3.- COMMISSIONING AND OPERATION

3.5.- CHECKING THE WATER FLOW RATE

It is very important that the unit operates at the correct water flow rate. It is dangerous to leave the unit operating at a low flow rate as this could result in serious damage to components as well as the water exchanger. If the unit operates at too high a flow rate, this will also hinder optimum performance. The best way of determining the operating flow rate is to measure the temperature difference between the inlet and water outlet.

Checking the water flow rate (it is vital to measure the thermal peak) (Standard unit)

For nominal and minimum water flow the difference between the inlet and water outlet temperature should be 5°C (cooling and heating pump units in cooling cycle only) for an inlet temperature of 12°C, an outlet temperature of 7°C and an outside temperature of 35°C. If these conditions change, the unit capacity will also change and as a result for nominal flow the difference between the inlet and water outlet temperature will vary slightly from 5°C as can be seen in the following table, based on nominal flow rate.

		ΔT (Water inlet temperature - Water outlet temperature)						
		Outside temperature (°C)						
Water outlet °C		15	20	25	30	35	40	45
7		6,1	5,8	5,5	5,3	5,0	4,7	4,4
9		6,5	6,2	5,9	5,6	5,3	5,0	4,7
11		7,0	6,7	6,4	6,0	5,7	5,4	5,0

If the unit must be started in the heating cycle and if you wish to operate at nominal cooling rate, the following shows the approximate differences between the inlet and water outlet temperatures for the various conditions.

		ΔT (Water inlet temperature - Water outlet temperature)				
		Outside Temperature (°C BH)				
Water outlet °C		-6	0	6	12	18
35		4,5	5,5	6,5	7,5	8,5
50		4	5	6	7	8

NOTES:

- The unit control system displays the inlet and water outlet temperature to be displayed. See the Control Description section.
- Check that the correct water pump has been selected, taking into account the loss of pressure in the hydraulic system. It is dangerous to let the unit run at a low rate and any faults which may result will not be covered under warranty.
- Do not start up the air conditioning units or the fan coils until the water temperature reaches the set temperature or use an automatic control device which cancels the air conditioning unit operation if the installation is not properly set.
- When everything is operating normally, take a reading of all the data and **fill out the Commissioning Sheet**.

3.- COMMISSIONING AND OPERATION

3.6.- WATER ANALYSIS

The water must be analyzed. According to the results of the analysis, the installed hydraulic network must include all the necessary elements for the water treatment: filters, additives, intermediate exchangers, purge valves, vents, isolation valves, etc,...

We do not advise operation of the units with open loops which can cause problems with oxygenation, or operation with untreated ground water.

The use of untreated, or improperly treated, water can lead to scale, algae and sludge build-up, or corrosion. It is advisable to consult a qualified water treatment specialist to determine the type of treatment required. The manufacturer cannot be held responsible for damage caused by the use of untreated or improperly treated water, salt water or seawater.

Here are our non exhaustive recommendations given as an indication:

- No NH₄⁺ ammonium ions in the water, they are very detrimental for copper <10mg/l.
- Cl⁻ Chloride ions are detrimental for copper with a risk of perforations by corrosion by puncture. < 10 mg/l.
- SO₄²⁻ sulphate ions can cause perforating corrosion.< 30 mg/l.
- No fluoride ions (<0.1 mg/l).
- No Fe₂⁺ and Fe₃⁺ ions with dissolved oxygen. Dissolved iron < 5 mg/l with dissolved oxygen < 5 mg/l. Over those values, it means a corrosion of steel which may generate a corrosion of copper parts under deposit of Fe – this is mainly the case with shell and tube heat exchangers.
- Dissolved silicon: silicon is an acid element of water and can also lead to corrosion risks. Content < 1mg/l.
- Water hardness: TH > 2.8 K. Values between 10 and 25 can be recommended. This will facilitate scale deposit that can limit corrosion of copper. TH values that are too high can cause piping blockage over time.
- TAC < 100.
- Dissolved oxygen: Any sudden change in water oxygenation conditions must be avoided. It is as detrimental to deoxygenate the water by mixing it with inert gas as it is to over-oxygenate it by mixing it with pure oxygen. The disturbance of the oxygenation conditions encourages destabilisation of copper hydroxides and enlargement of particles.
- Specific resistance - Electric conductivity: The higher the specific resistance, the slower the corrosion tendency. Values above 3000 Ohm/cm are desirable. A neutral environment favours maximum specific resistance values. For electric conductivity values in the order of 200-6000 S/cm can be recommended.
- pH (hydrogen potential): neutral pH at 20°C, according to the values in the glycol safety data sheet.

4.- MAINTENANCE

When carrying out maintenance works on these units, please make a correct segregation of the non-hazardous waste generated: insulation, air filters, plastic or metallic elements, packaging, etc., as well as waste considered hazardous: oils, filters and rags Impregnated with oils, welding elements such as filler material, strippers, electrical and electronic waste, batteries, lamps, etc., these must be managed by an authorized dealer.

The refrigerant gas can be reused, or collected in a bottle and managed as hazardous waste by an authorized dealer.



WARNING: Conductor cables: Electrical shock. Follow lockout / tagout procedure and national regulations before performing any maintenance or service work on the system.

Screwed electrical connections must be used in all applications. Refer to original equipment wiring diagrams. Electrical connections must be made by qualified electrical personnel.



WARNING:

Ignition source in a potentially flammable atmosphere: Fire hazard. When opening the system, the atmosphere could be flammable. All electrical components that are a source of ignition must always be turned off during service and maintenance. Ensure that the surface temperatures of the components never exceed the limits set by the applicable safety standard.

Air - flammable refrigerant mixture: Fire hazard. Remove all refrigerant before opening the system. Make sure to remove refrigerant from all components (heat exchangers, refrigerant accumulators,...). Flush system and components with inert gas before carrying out any work.



WARNING:

Open flame in a potentially flammable atmosphere: Fire hazard. The area should be checked with an appropriate refrigerant detector prior and during work, to ensure the technician is aware of potentially toxic or flammable atmospheres. Ensure that the leak detection equipment used is suitable for use with all applicable refrigerants. Personnel performing work on a refrigeration system that involves exposing the pipework shall be avoid using any source of ignition in a way that could lead a fire hazard. All sources of ignition shall be kept sufficiently far from the site of installation, repair, removal or disposal during the entire time when refrigerant could be released into the surrounding space.

Open flames and smoking are strictly prohibited at all times.

During service made sure that:

- the area is well ventilated.
- the materials and equipment used are suitable for use in flammable conditions.
- only non-sparking tools are used.
- antistatic gloves and clothing are used.
- build-up of electrostatic charges is avoided.
- no unshielded or naked flame is allowed.
- if parts of the refrigeration system are charged with flammable refrigerant, be sure that all valves are tightly closed and that the open pipes after the valves are free of refrigerant and oil.

IMPORTANT:

- Only qualified and trained personnel can repair or carry out work on units that use flammable refrigerant. Personnel working on maintenance, repair and decommissioning must be properly trained. Any work procedure that affects safety (for example; breaking into the refrigeration circuit, opening sealed components, opening ventilated enclosures,...) must only be carried out by qualified and trained personnel in accordance with national certification systems or others equivalents.

- It is recommended that, to carry out an intervention, the staff have a work procedure:

* If any work is to be conducted on the refrigeration systems, appropriate fire-fighting equipment (dry powder extinguishers, CO₂ extinguishers,...) shall be provided and be confirmed that it is available near the work area .

* Before starting work on these systems with flammable refrigerants, safety checks are necessary to ensure that the risk of ignition is minimised.

* Work shall be undertaken under a controlled procedure so as to minimize the risk of a flammable gas or vapour being present while the work is being performed.

- It is recommended that the service technician perform a risk analysis to assess all possible risks prior to any repair work.

4.- MAINTENANCE

4.1.- PREVENTIVE MAINTENANCE



PREVENTIVE MAINTENANCE PREVENTS COSTLY REPAIRS.

We recommend regular and thorough servicing of the LENNOX unit. It is therefore advisable to ask your dealer about maintenance contracts. Check maintenance of the following points indicated (depending on the operating conditions maintenance every 6 months may be necessary).
Local legislation always takes precedence.



Unit working with slightly flammable refrigerant. Before any intervention on the unit, realize a refrigerant detection with a dedicated device in order to ensure no possible presence around the unit.



During the life-time of the system, inspection and tests must be carried out in accordance with national regulations. The information on operating inspections given in annex C of standard EN378-2 can be used if no similar criteria exist in the national regulations.

- GENERAL CONDITION OF THE CARPENTRY:

Check the state of the casing, paint, deterioration due to bumps, rust spots, leveling and supporting, state of the antivibration mounts, if installed, screwed panels, etc.

- ELECTRICAL CONNECTIONS AND INTERCONNECTIONS:

Check the State of cables, tightening of screws, grounding, current draw of the compressor and fans and checking that the unit is receiving the correct voltage.

- REFRIGERANT CIRCUIT:

Check that pressure values are correct and that there are no leaks. Check that there is no damage to the pipe insulation, that the state of the batteries is correct and that there are no chips or clogs retained by the air flow, etc.

- COMPRESSOR:

Inspect the oil level.

Inspect the condition of the compressor mountings.

- FANS:

Check that fans turn freely and in the correct direction without excessive noises.

- CONTROL:

Check the Set Points and normal operation.

- WATER:

If the installation contains anti-freeze, regularly check the state of the anti-freeze as well as the cleanliness of the water.

- WATER FILTER:

Clean the water inlet filter if necessary.

- WATER PUMP:

When the installation is going to work with percentages of glycol up to 20% and water temperatures below -5°C, even do we use a specific closing for the water pump, it is advisable to clean the water pump's closing every year and a half, in order to avoid leaks by crystallization.

- PLATE EVAPORATOR:

Prove the general isolation state and tightness of the water connections.

- REFRIGERANT AND WATER LEAKS:

Check the general condition of the refrigerant circuit with a refrigerant leak detector valid for R32.

Check the general condition of the refrigeration circuit. Due to the operation of the compressor, sounds and/or vibrations may be produced, which may cause cracks that may lead to refrigerant leakage. This situation must be avoided by the manufacturer - installer of the system. The most important objective is to guarantee minimum vibration in all directions to avoid transmitting vibrations to the structure to which the lines are attached.

- DRIVER ELECTRICAL BOX:

Periodically check and clean (depending on environmental contamination) the filters on the front and rear grilles of the electrical panel of the compressor's variable speed drive.



WARNING:

Vibrations: Creation of a flammable atmosphere. Carefully check the system for vibrations.

4.- MAINTENANCE

4.2.- MAINTENANCE PLAN

N°	MAINTENANCE PLAN		Monthly	+ Quarterly	Half Yearly
	Task	Operating mode			
1	Inspection of the microchannel coils aluminum-copper connexions for corrosion.	Proper care to be given when cleaning the coils. If corrosion is detected, a preventive treatment needs to be done following our recommendations.			
2	Cleanning the coils (In accordance with local regulations).	It's mandatory to clean the external coils, according to the environment where the unit is located, the frequency of the cleaning varies from once in a month to minimum twice in a year. The performance and the sustainability of the machine is based on the perfect heat exchange. The use of a neutral pH cleaning product is mandatory. (WARNING: Fins and copper tubes are very fragile! Any damage WILL reduce the performances of the unit).			
3	Inspection of compressor's electrical current.	Check the electrical current of each compressor on the 3 phases of partial load and at 100% - with a certain frequency, according to the utilization of the machine. Example: Monthly: If the unit is used all over the year. Half Year: If seasonal use.			
4	Electrical cabinets air-filters cleanning.	It's mandatory to clean the filters at least once a month according to environment where the unit is located to avoid overheating the electrical components. Check the filter fouling rate, clean or replace it when needed by an original filter.	•	•	•
5	Inspection of the condensors fans.	Check the rotation of the fan (free rotation, detection of vibrations or bearing noises). Check for the Amps consumed on all three phases; compare it with the nominal value given in the electrical wiring diagram. Check the status of the fan blades and its protections.			
6	Visual inspection of the oil level and check the oil for traces of acidity in the refrigerant circuits.	Visually check the oil level through the sight glass on the side of the compressor casing. Test the oil every 3 years and/or after each intervention on the refrigerant circuit.			
7	Check the 4-way valve.	During cooling mode, reverse to Heat Pump mode. Reset the control.			
8	Check the position of the crankcase heaters (around the compressor) and it's proper functioning.	Ensure crankcase heaters is well fitted and secured. Verify the operation of the crankcase heaters.			
9	Verification of the defrost cycle with 4-way valve inversion.	Switch the unit to heat pump mode. Change the set point to obtain the standard defrost mode and reduce the cycle time to the min value. Check the operation of the defrost cycle.			
10	If possible, check for water pressure in the circuit.	Check the water pressure in the circuit and the efficiency of the expansion vessels.		•	
11	Check overall working of the flow controller.	Cut-off the compressors, stop the water circulation. Then start the unit and wait for the water flow fault signal in the controller.			
12	Check the circulation pumps.	Check the absorbed electrical power and the correct rotation of the pumps. Check if there is no leakage of water at pump seal and if needed follow the manufacturer maintenance plan.			

N°	MAINTENANCE PLAN		Monthly	+ Quarterly	Half Yearly
	Task	Operating mode			
13	Check water flow.	Measure the water flow rate and compare to the selected value from the technical datasheet.			
14	Inspection and cleaning the water filter.	ATTENTION: The water circuit can be under pressure. Follow the usual precautions when depressurizing the circuit before opening. Ignoring this rules can lead to accidents and cause injury to the personal.			
15	Check for water leakage in the unit and it's accessories.	Verify the gaskets, if cracked or ripped, repair them or replace them. Check for water leaks and repair if it's needed.			
16	Check CLIMATIC™ control, set-points and variables.	Refer to the commissioning sheet; Check all set points are set according to this document.			
17	Check refrigeration system for proper functioning (Thermal expansion valve).	Retrieve/Check the values for superheating and sub cooling. Resume the expansion valve settings when needed, verify the behavior in partial loads and at 100%. Resume settings to obtain superheat between 5K and 10K.			
18	Check refrigeration system for proper functioning (Electronic expansion valve).	Retrieve/Check the values of the pressure and temperature sensors. Check also for the good behavior of the expansion valve (Open/closed) in full load and partial load conditions. The superheat must be between 5K and 8K.			
19	Check the position and tightness of refrigeration components.	Check systematically all connections and fixings on the refrigeration circuit. Check for oil traces, eventually a leak test should be conducted. Check operating pressures correspond to the ones indicated on the commissioning sheet.			
20	SIGHT GLASS (when applicable).	The liquid refrigerant flow through the sight glass should be steady and without bubbles. Bubbles are a sign of a low charge, a possible leak, or of a restriction in the liquid line. Each sight glass is fitted with a humidity indicator. The color of the element changes according to the level of humidity in the refrigerant, but also according to temperature. It should indicate «dry refrigerant. If it shows «wet» or «CAUTION», contact a qualified refrigeration technician. CAUTION: when starting up the unit, run the compressor for at least 2 hours before taking a humidity reading. The humidity detector is also sensitive to temperature, and as a consequence, the system must be at normal operating temperature to give a meaningful reading.			
21	Check antifreeze protection.	Test antifreeze function (leakage rate, frost protection thermostat)			
22	Check refrigeration 3-way valve.	Check the proper functioning of the system.			
23	Check tightness of all electrical connections.	Power down the unit and check and tighten all the screws, terminal and electric connections (including the terminal boxes) When turning on the unit, check for the deterioration of the electrical components with a thermal camera while the unit is working at 100% of its power.			
24	Check HP / LP safety switches.	Install a pressure gauge high / low pressure and check if the safety switches for its overall working.			

N°	MAINTENANCE PLAN		Monthly	+ Quarterly	Half Yearly
	Task	Operating mode			
25	Check the position of all sensors.	Check the position and the fixation of all sensors.			•
26	Check anti-vibration mountings, for wear and tear.	Visually check anti-vibration mountings on compressors and centrifugal fan. Replace it, if damaged.			•
27	Check glycol concentration in the water circuit.	Check the glycol concentration in the pressurized water circuit. (a concentration of 30% gives a protection down to approx.. -15°C) check the circuit pressure.			
28	Check casing and equipment corrosion.	To treat and neutralize eventuals rust spots.			•
29	Check the water pump.	When the unit is operated with glycol up to 20% and the water temperature below -5°C, even if you use a specific thermal protection for the pump, it is advisable to clean the body of the pump every 18 months in order to avoid leaks by crystallization. (see supplier catalogue).			
30	Plate exchanger.	Verify the general insulation state, the tightness of the water connection and the freeze protection.			
31	Check the expansion vessel (if applicable).	Measure the pressure under the different water modes (from +7°C to +45°C).			
32	Check the software version.	Contact the manufacturer for updates.			

It is therefore advisable to ask your dealer about maintenance contracts. Local legislation must be respected.

When carrying out maintenance works on these units, please make a correct segregation of the non-hazardous waste generated - insulation, air filters, plastic or metallic elements, packaging, etc. - as well as waste considered hazardous: oil filters and rags impregnated with oils, welding elements such as filler material, strippers, electrical and electronic waste, batteries, lamps, etc. They must be managed by an authorized dealer.

The refrigerant gas can be reused, or collected in a bottle and managed as hazardous waste by an authorized dealer.

Symbols and legends:

• Operation which can be carried out by on-site maintenance technicians.

| Operation which must be carried out by qualified refrigeration personnel, trained to operate on this type of equipment.

4.- MAINTENANCE

4.3.- CLEANING THE CONDENSER

4.3.1.- Air cooled condensers

Clean the coils either with a vacuum cleaner, cold water, compressed air, or with a soft brush (non metallic). On units installed in a corrosive atmosphere, coil cleaning should be part of the regular maintenance program. On this type of installation, all dust gathered on the coils should be quickly removed by regular cleaning.

Caution: Do not use high pressure cleaners that could cause permanent damage to the aluminium coil fins.

Specific maintenance of microchannels exchangers connection



For microchannel heat exchangers, the coil connexion to the circuit is made by means of a solder copper / aluminum. This connection is protected from galvanic corrosion by a special resin encapsulated in a heat-shrinkable sheath.

This sleeve must be regularly visually inspected during unit cleaning operations to detect a possible premature deterioration.



Good shape



Bad shape

Indeed with slightly corrosive atmospheres, a small copper etching can lead to a loss of adhesion of the resin thus allowing moisture to seep under the sleeve while triggering galvanic corrosion phenomena between the aluminum and the Copper.

If this attack is not detected in time, a leak may appear and then force change of the exchanger.



Galvanic corrosion under the plastic sleeve.



A LEAKAGE BY CORROSION DUE TO A LACK OF CONDENSER MAINTENANCE IS NOT COVERED BY UNIT WARRANTY

4.- MAINTENANCE

4.3.- CLEANING THE CONDENSER

In case of deterioration of the sleeve, it must be removed and replaced by polyurethane sealant - like Sikaflex 221 or equivalent. In this case the recommended procedure is as follows :

Step 1

Remove the damaged sleeve by operating a longitudinal section as in the photo below :



Step 2

Clean the connection with a wire brush and a synthetic abrasive as one can find on the back of kitchen sponges :



Step 3

Clean and dry the connector with paper towels and acetone to remove any grease or surface pollution.

Step 4

Apply polyurethane sealant – like Sikaflex 221 - with a pistol and then spread it over the entire surface to be covered with a brush :



Feel free to add some polyurethane sealant to ensure complete coverage of the area.

4.3.2.- Plate heat exchanger condensers

Use a non corrosive solvent to remove scale deposits. The equipment to be used for external water circulation, the quantity of solvent and the safety measures to be taken must be approved by the company supplying the cleaning products or by the company conducting these operations.

4.- MAINTENANCE

4.4.- PROCESS FOR REPLACING A COMPRESSOR ON THE FIELD

When servicing these units, replacing the compressors is one of the most critical procedures. It should be done following this process:

- 1.- Unweld the discharge and suction lines of the refrigeration circuit.
- 2.- Unscrew the screws of the compressor rails.
- 3.- Slide the rails of the compressors out of the unit.
- 4.- Replace the compressor.
- 5.- Slide again the rails inside the unit and fix the rails.

When replacing an A2L refrigerant compressor, the oil must be drained from the compressor and the compressor must be flushed with dry nitrogen. DO NOT close the ends with plugs.



WARNING: Air/refrigerant mixture A2L: Fire hazard. Use a suitable recovery unit and recycling bottles also to dispose of the oil, as the A2L refrigerant can still dissolve in the oil. For systems using flammable A2L refrigerant, it is mandatory to purge oxygen-free nitrogen through the piping during the brazing process.



CAUTION: Inadequate lubrication: Destruction of bearings. Change the accumulator after replacing a compressor with a burned out motor. The accumulator oil return hole or screen may be clogged with debris or may be clogged. This will result in a lack of oil to the new compressor and a second failure. Completely remove the refrigerant and oil from the replaced compressor.

During the execution of these compressor change tasks in the field, the following recommendations must be followed:

- Continuously check if the ambient atmosphere is flammable. If a flammable atmosphere is detected, ensure a adequate ventilation of the work space and immediately cut off the power supply.
- Resume work after the atmosphere is no longer dangerous.
- Recover the refrigerant from the refrigeration circuit using a suitable recovery unit. During this action, the compressor crankcase heater could be activated; deactivate immediately in case an atmosphere is detected flammable.
- Recover at an absolute pressure of 3 mbar or less. To obtain the best results and also recover the refrigerant dissolved in the oil, run the recovery unit two or three times as needed.
- Open the system with a cutting tool and flush the entire system with dry, oxygen-free nitrogen.
- Disassemble the compressor with a cutting tool. Properly drain and recover compressor oil. Flush the compressor again with dry nitrogen for a few minutes.
- If it is necessary to return a compressor to the manufacturer for analysis, it must be returned without oil and with the connections open. Do not close the connections with plugs.
- Collect and secure the oil properly. Provide information on the amount of oil drained from the compressor and its color.
- Dispose of the oil in accordance with local rules and regulations.

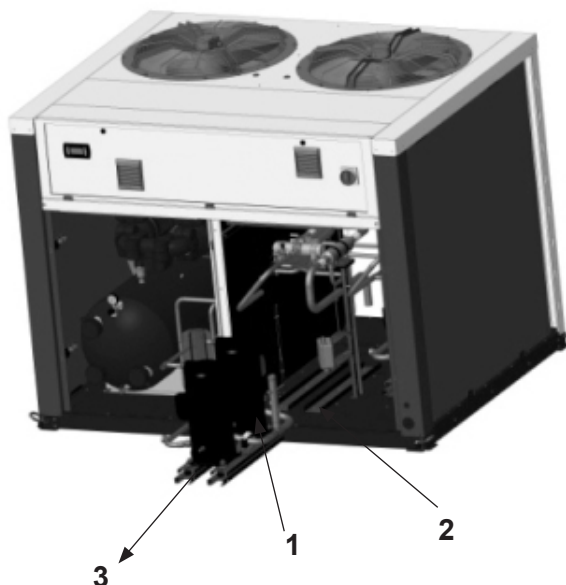

4.- MAINTENANCE

4.5.- CORRECTIVE MAINTENANCE



IMPORTANT MAKE SURE THAT THE UNIT IS COMPLETELY DISCONNECTED FROM THE POWER SUPPLY WHEN CARRYING OUT ANY TYPE OF WORK ON THE MACHINE.

If some component in the cooling circuit must be replaced, follow these recommendations:

- Always use original replacement parts.
- Regulation imposes the recovery of refrigerant fluids, as well as preventing their discharge into the atmosphere. The refrigerant must be recovered and evacuated from the refrigeration circuit using a recovery unit and a vacuum pump dedicated to A2L. It must be ensured that the outlet of the vacuum pump is not near any potential source of ignition and that ventilation is available.
- The system must be flushed with inert gas (dry nitrogen). Compressed air or oxygen must not be used to purge refrigerant systems.
- If cuts must be made in the pipe work, use pipe cutters. Do not use saws or any other tools that produce filings.
- All brazing must be carried out in a nitrogen atmosphere to prevent corrosion from forming. Use silver alloy brazing rod.
- Take special care that the flame from the torch is aimed in the opposite direction from the component to be welded and is covered with a wet rag in order to avoid overheating.
- Disassemble the components with a cutting tool.
- Drain, recover and dispose of the compressor oil as appropriate.

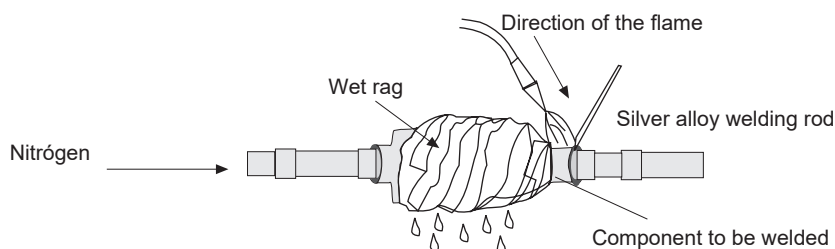

- Take very special care if 4-way check valves are to be replaced since these have internal components that are very heat-sensitive (plastic, teflon etc...).
- If a compressor must be replaced, disconnect it electrically and un-braze the suction and discharge lines. Remove the securing screws and replace the old compressor with the new one. Check that the new compressor has the correct oil charge, screw it to the base and connect the lines and electrical connections.
- Carry out the vacuum above and below through the Schrader valves of the outdoor unit until -750 mm Hg is reached.
- Once this level of vacuum has been reached, keep the pump in operation for at least one hour. **DO NOT USE THE COMPRESSOR AS A VACUUM PUMP.** If the compressor runs in vacuum it will fail.
- Charge the unit with refrigerant according to the data on the Rating Plate for the unit and check that there are no leaks.



PRECAUTIONS TO BE TAKEN IN THE USE OF R32 REFRIGERANT

The following precautions characteristic of this gas should be taken:

- The Vacuum Pump must have a Check Valve or Solenoid Valve.
- Pressure Gauges and Hoses for the exclusive use with R32 Refrigerant should be used.
- The charge should be carried out in the Liquid Phase.
- Always use scales to weight-in charge.
- Use the Leak Detector exclusive for R32 Refrigerant.
- Do not use mineral oil, only synthetic oil to ream, expand or make connections.
- Keep pipes capped before using them and be very thorough about any possible moisture and dirt (dust, filings, burrs, etc.).
- Brazing should always be carried out in a nitrogen atmosphere.
- Reamers should always be well sharpened.
- The refrigerant bottle must contain at least 2 % of the total amount.
- All the components derived from the recycling of the unit should be managed according local legislation, and have to be classified and separated while dealt by authorized waste manager or be left in local waste facilities.
- Refrigerant fluids, electronic boards, heat exchangers and the oil extracted from the refrigerant circuit, as well as the oil recipients used must be recycled as hazardous waste according the local normative through an authorized waste manager or be left in local waste facilities. The rest of the components considered as non-hazardous wastes must be recycled according to the corresponding norms.
- At the end of its life, the equipment should be recycled in local waste facilities or by an authorized waste manager.

4.- MAINTENANCE

4.6.- REFRIGERANT EMISSION CONTROL

It is recommended to reduce refrigerant emissions to a minimum following the corresponding operation, maintenance and service procedures recommended by LENNOX:

- The refrigerant recycling procedure must be established before starting the intervention.
- The used refrigerant must always be recovered for its later reuse or recycling. The refrigerant should never be released into the atmosphere.
- Recycling equipment must be used which guarantees the lowest possible vacuum while the refrigerant is recovered and of this manner, minimizes its emissions.
- It is advisable to use cleaning methods for the refrigerant circuit using filters and dryers. Solvents which are not environmentally friendly should never be used. The materials used during these processes must be recycled correctly.
- Storage containers which comply with current legislation should always be used. Also, current regulations must be applied during the transportation of these refrigerant containers.
- All equipment used for these procedures (gauges, hoses, vacuum pumps,...) must be maintained in perfect condition, following the established calibration periods.
- To try to improve the performance of the equipment and reduce energy consumption, it must be considered to perform adequate preventive maintenance periodically.
- It is advisable to check the manufacturer's recommendations from time to time to reduce refrigerant emissions and increase the efficiency of the units. These improvements of the units could be through conversion refrigerants and/or compatible parts which must follow specific LENNOX guidelines.

4.7.- COMPRESSOR MAINTENANCE

Compressors replacement: Mechanical and/or electrical failures.

If in the unit happens a failure in the compressor, it is recommended to follow these procedures to replace it:

- To lift a compressor, you must always use the two lifting eyes which each compressor has. LENNOX recommends using lifting techniques approved in accordance with current applicable regulations to carry out this operation in complete safety.
- After a mechanical failure in a compressor, the oil must always be changed in all compressors corresponding to the set (TRIO / TANDEM) and it is recommended to replace the liquid line filter drier.
- After an electrical failure in a compressor, the oil must always be changed in all compressors corresponding to the set (TRIO / TANDEM), replace the liquid line filter drier and add a suction filter drier with clean-up cores.



**A compressor should NEVER be lifted using a single lifting eye.
The refrigerant piping should NEVER be modified because this action could affect the lubrication of the compressor.**

4.- MAINTENANCE

Refrigerant piping:

To facilitate welding and avoid possible leaks in the refrigerant piping, the connections and compressor suction and discharge piping are made of copper.

During maintenance and service works, the refrigerant piping can be reused. In cases where they cannot be reused, it is recommended that the customer request these replacement parts from LENNOX technical service to avoid altering the configuration of the refrigerant piping and possible incorrect operation of the unit.

If it is necessary to cut the tubes of the refrigerant installation should be done using a tubing cutter and it is recommended to clean these areas using a suitable suction system to prevent copper shavings from entering the system.



The compressor suction line configuration should NEVER be modified. Change this configuration could cause a inadequate oil return to the compressors.

Refrigerant circuit opening time:

According to previously indicated in this manual, these units use POE oil, so it is recommended to minimize the exposure time of the refrigerant circuit, applying the following recommendations:

- The maximum opening time of the refrigerant circuit should never exceed one hour but depending on the environmental conditions this time could be reduced.
- It is recommended to evacuate the circuit to 500 microns or less.
- The compressor should always be re-sealed until it is installed again in the unit.
- Always keep POE oil containers closed to avoid exposure to the atmosphere.
- To minimize humidity absorption in the system, it is recommended to seal the refrigerant circuit and change the liquid line filter drier.

Compressor electrical connections:

For the rotation of the compressors used in these units to be correct, they must be perfectly wired, and their correct rotation must be verified using a rotation meter.

Although the reverse rotation of these compressors is not a terrible mistake for these models, it must be corrected as soon as possible because a negative impact on the bearings will be avoided.

The proper rotation of these compressors is following phases: L1 -L2 - L3. If these compressors are connected incorrectly, they carry out an excessive noise, do not pump and consume approximately half the normal current. If they stop operating for a long period of time, the compressors can become overheated.

When welding works are carried out on the connections of the refrigerant circuit piping with the compressors, it is recommended to protect their electrical boxes.



To verify the correct rotation of a compressor you should NEVER hit, because an incorrect rotation could cause failures in the compressor motor in a few seconds.



Compressor crankcase heaters:

- Due to it is necessary heat the oil refrigerant before starting the compressors, the crankcase heaters must be energized at least eight hours before starting the unit.
- Due to the crankcase heaters must always be energized before starting the compressors, the ambient temperature is not considered an important factor to consider.

4.- MAINTENANCE

Oil level:

To correctly verify the oil level, the compressors must be switch off and wait a few minutes before carrying out some reading operation. In TANDEM and/or TRIO compressor configurations, the oil level equalizes after switching off.

The oil level in the compressors should never be lower than the bottom of the sight glass or higher than the full sight glass. When these compressors are operating in a TANDEM and/or TRIO configuration, each compressor could have a different oil level. The oil level could be at the bottom of the sight glass but should always be visible.

Oil equalization line:

To facilitate the extraction of the oil equalization line, this piping is equipped with a Rotolock connector. Before separating the oil equalization line from the compressors, the oil must be drained to a level below the connector of this piping. This operation must be carried out in all compressors using the oil drain valve which each compressor has. Consider that if the oil drains below the level of the sight glass will be below the level of the oil equalization line. To drain the oil correctly, it is recommended to pressurize the low side of the compressor using nitrogen.

Oil filling, extraction and capacity:

To add or remove oil from compressors, it is recommended to use oil charging valves which have a dip tube that is extended to the bottom of each compressor.

To avoid that the humidity enters the refrigerant circuit when oil is added, this operation must be carried out following the manufacturer's guidelines, due to the POE oil used in these units easily absorbs and retains humidity. A vacuum pump can be used to remove the humidity from the oil, considering that is a difficult process. Also, it is recommended that once a POE oil container is opened, it must always be used.

In these units, only the oil specified by LENNOX in this manual should be used and under no circumstances should any other POE oil with similar characteristics be used.



WARNING: Oil should **NEVER** be reused once extracted from the compressors.



Suction restrictors for TANDEM and/or TRIO compressors:

Due to different size compressors are used in these units for TANDEM and/or TRIO configurations, these compressor combinations could require the use of a restrictor in the suction line of one or more compressors to avoid an imbalance in the oil level between the compressors when are in operation.

Oil tests:

If it is necessary, it is recommended to carry out an oil analysis in a laboratory specialized in oil analysis for these units. This analysis must provide a vision of the compressor and the refrigerant circuit conditions: presence of water, wear elements, viscosity, acidity, dielectric data,...

If once this analysis has been carried out, unacceptable wear conditions are shown, a change in the characteristics of the oil is evident, so its replacement is recommended to avoid further problems.

4.- MAINTENANCE

4.8.- DISPOSAL OF EQUIPMENT

Equipment shutdown and oil and refrigerant recovery should be performed by qualified personnel in accordance with NF EN 378. All parts of the refrigeration system, for example, refrigerant, oil, heat transfer fluid, filter, dehydrator, insulation materials must be recovered, reused and / or made available properly (see NF EN 378 part 4). No rejections will be made in the environment.



Legislation does not allow refrigerant gas emissions to the atmosphere, so the refrigerant have to be recycled to avoid being released to the atmosphere.

**Those recycled refrigerants shall be processed afterwards by an authorized waste manager.
Those components derived from the recycling of the unit have to be managed by authorized waste manager or be left in local waste facilities according the local normative in each country.**

4.9.- PRESSURE RELIEF VALVES

It is recommended to check pressure relief valves every 36 - 48 months according to the manufacturer's instructions. This operation is entrusted to qualified and trained personnel in compliance with the regulation in force in the country where the maintenance is performed.

5.- END OF THE MACHINE LIFE

The refrigerating system is designed for a working life of at least 12 years if the safety and maintenance instructions are strictly respected.

The equipment can be renewed in its lifespan of the periodic requalification certificate is validated by the expert (Authorized body or according to current local regulations).

At the end of the useful life of the units, please take into account the correct segregation of the waste generated. No Hazardous like: Painted metallic parts, plastic elements, copper pipes, batteries, exchangers, liquid receivers, water pumps, fans.. And Hazardous Materials such as batteries, electrical and electronic elements, compressors, dehydrating filters, valves or refrigerant gas, etc. to be managed with an authorized dealer.

6.- TROUBLESHOOTING - REPAIRS

6.1.- LIST OF THE MOST COMMON PROBLEMS

A.- THE COMPRESSOR DOES NOT START

PROBLEMS - SYMPTOMS	PROBABLE CAUSE	RECOMMENDED ACTION
<ul style="list-style-type: none"> Motor control circuits established, the compressor does not run 	<ul style="list-style-type: none"> No power supply 	<ul style="list-style-type: none"> Check main power supply and switch positions
	<ul style="list-style-type: none"> Compressor motor burnt out 	<ul style="list-style-type: none"> Replace
<ul style="list-style-type: none"> Low voltage reading on voltmeter 	<ul style="list-style-type: none"> Voltage too low 	<ul style="list-style-type: none"> Contact power company
<ul style="list-style-type: none"> The system does not start 	<ul style="list-style-type: none"> Breaker tripped or fuses blown 	<ul style="list-style-type: none"> Determine the cause. If the system is in running order, close the disconnect
		<ul style="list-style-type: none"> Check condition of fuses
	<ul style="list-style-type: none"> No water flow in the evaporator or condenser 	<ul style="list-style-type: none"> Measure flow, check the water pump and water circuitry and filters
	<ul style="list-style-type: none"> Flow switch contacts open 	<ul style="list-style-type: none"> Find the cause of the trip out
		<ul style="list-style-type: none"> Check circulation of liquid in the evaporator, and the condition of the flow switch
	<ul style="list-style-type: none"> Anti short cycle relay action 	<ul style="list-style-type: none"> Wait until the anti short cycle time delay has expired
	<ul style="list-style-type: none"> Faulty control thermostat 	<ul style="list-style-type: none"> Check for proper operation, set points, contacts
	<ul style="list-style-type: none"> Antifreeze thermostat tripped 	<ul style="list-style-type: none"> Check evaporating pressure and the condition of the antifreeze thermostat
	<ul style="list-style-type: none"> Compressor thermal protection relay tripped 	<ul style="list-style-type: none"> Check for proper operation of the relay
<ul style="list-style-type: none"> High pressure safety switch tripped 	<ul style="list-style-type: none"> Check the condensing pressure, and the condition of the high pressure safety switch 	
<ul style="list-style-type: none"> Normal operation with too frequent starts and stoppages due to low pressure alarm. Or, normal compressor operation, but the low pressure alarm trips out and resets frequently 	<ul style="list-style-type: none"> Low refrigerant charge 	<ul style="list-style-type: none"> Check the charge through sub-cooling value, carry out a leak test, then top up the refrigerant charge
<ul style="list-style-type: none"> Suction pressure too low, Filter drier frozen up 	<ul style="list-style-type: none"> Filter-drier obstructed 	<ul style="list-style-type: none"> Check the state of the drier and replace the filter
	<ul style="list-style-type: none"> Expansion valve closed 	<ul style="list-style-type: none"> Check operation of the valve

B.- THE COMPRESSOR SHORT CYCLES ON HIGH PRESSURE SAFETY SWITCH TRIP OUT

PROBLEMS - SYMPTOMS	PROBABLE CAUSE	RECOMMENDED ACTION
<ul style="list-style-type: none"> The compressor short cycles on high pressure safety switch trip out 	<ul style="list-style-type: none"> High pressure safety switch trip out 	<ul style="list-style-type: none"> Check high pressure safety switch differential
	<ul style="list-style-type: none"> Low air flow in condenser or dirty condenser coil (poor heat exchange) 	<ul style="list-style-type: none"> Check that fans are operating correctly or the state of cleanliness of the coils
	<ul style="list-style-type: none"> Incondensable substances in the refrigeration circuit 	<ul style="list-style-type: none"> Bleed from circuit and top up the refrigerant charge. Note : it is not permitted to discharge refrigerant to atmosphere

6.- TROUBLESHOOTING - REPAIRS

C.- THE COMPRESSOR RUNS IN LONG CYCLES OR RUNS CONTINUOUSLY

PROBLEMS - SYMPTOMS	PROBABLE CAUSE	RECOMMENDED ACTION
	<ul style="list-style-type: none"> Faulty control thermostat 	<ul style="list-style-type: none"> Check operation
<ul style="list-style-type: none"> Temperature too low in the conditioned space 	<ul style="list-style-type: none"> Chilled water thermostat set too low 	<ul style="list-style-type: none"> Adjust it
<ul style="list-style-type: none"> No sub-cooling in the system at full load 	<ul style="list-style-type: none"> Low refrigerant charge 	<ul style="list-style-type: none"> Check the refrigerant charge in the sight glass and top up if necessary
	<ul style="list-style-type: none"> Filter-drier partly obstructed 	<ul style="list-style-type: none"> Check the drier and replace as required, change the filter cartridge
	<ul style="list-style-type: none"> Expansion valve partly closed 	<ul style="list-style-type: none"> Check expansion valve bulb and capillary, measure superheat
	<ul style="list-style-type: none"> Liquid line valve not open far enough 	<ul style="list-style-type: none"> Open the valve completely
<ul style="list-style-type: none"> Noisy compressor, or abnormally high suction pressure or low discharge pressure 	<ul style="list-style-type: none"> Leaky internal compressor valves/seals Low oil level 	<ul style="list-style-type: none"> Contact LENNOX, compressor may have to be changed. Add oil

D.- THE COMPRESSOR CUTS OUT BECAUSE OF OIL ISSUES

PROBLEMS - SYMPTOMS	PROBABLE CAUSE	RECOMMENDED ACTION
<ul style="list-style-type: none"> Oil level in sight glass is too low - 	<ul style="list-style-type: none"> Oil level is too low 	<ul style="list-style-type: none"> Check the oil level in the sight glass on the crankcase
<ul style="list-style-type: none"> Visible oil leak / Oil level too low 	<ul style="list-style-type: none"> Low oil charge 	<ul style="list-style-type: none"> Check that there is no leakage and add oil
	<ul style="list-style-type: none"> Leaky oil sump 	<ul style="list-style-type: none"> Repair and add oil
<ul style="list-style-type: none"> Suction line unusually cold, compressor noisy 	<ul style="list-style-type: none"> Liquid refrigerant present in the compressor crankcase 	<ul style="list-style-type: none"> Check appearance of the oil in the sight glass. Measure superheat at the expansion valve
	<ul style="list-style-type: none"> Poor heat exchange in the evaporator 	<ul style="list-style-type: none"> Check water flow. Check fouling by measuring the water pressure drop. Excessive oil migration in the circuit: measure evaporating pressure and superheat

6.- TROUBLESHOOTING - REPAIRS

E.- THE COMPRESSOR CUTS OUT ON ANTIFREEZE ALARMS

PROBLEMS - SYMPTOMS	PROBABLE CAUSE	RECOMMENDED ACTION
	• Antifreeze alarm tripped	• Check that the low pressure side sensor is operating properly
	• Low water flow in the evaporator	• Check the water pump
	• Evaporator obstructed	• Determine the degree of fouling by measuring water pressure drop
	• Evaporator frozen up	• Measure pressure drop in water circuit, keep water circulating until evaporator has thawed completely
	• Low refrigerant charge	• Check the refrigerant charge and add refrigerant if necessary
	• Liquid refrigerant in the compressor crankcase	• Check appearance of the oil in the sight glass. Measure superheat at the expansion valve, check that the valve sensors are tightly attached
	• Poor heat exchange in the evaporator	• Check water flow. Check fouling by measuring the evaporator pressure drop. Excessive oil migration in the circuit : measure evaporating pressure and superheat

F.- THE COMPRESSOR CUTS OUT ON ITS MOTOR PROTECTION THERMAL RELAY

PROBLEMS - SYMPTOMS	PROBABLE CAUSE	RECOMMENDED ACTION
	• Thermal protection tripped	• Check operation of thermal protection, change it if necessary
	• Motor windings are not being sufficiently cooled	• Measure superheat in the evaporator, adjust it if necessary
	• Compressor operating out of its application range	• Check operating conditions

G.- THE COMPRESSOR STARTS WITH DIFFICULTY

PROBLEMS - SYMPTOMS	PROBABLE CAUSE	RECOMMENDED ACTION
	• Faulty windings	• Replace the compressor
	• Mechanical problem	• Replace the compressor

H.- THE COMPRESSOR IS NOISY

PROBLEMS - SYMPTOMS	PROBABLE CAUSE	RECOMMENDED ACTION
• Compressor knocking	• Broken mechanical parts inside compressor	• Replace the compressor
• Suction line is unusually cold	• Liquid slugging	• Check superheat and that the expansion valve sensors are correctly installed
	• Expansion valve blocked in open position	• Repair or replace

6.- TROUBLESHOOTING - REPAIRS

I.- DISCHARGE PRESSURE TOO HIGH

PROBLEMS - SYMPTOMS	PROBABLE CAUSE	RECOMMENDED ACTION
<ul style="list-style-type: none"> Condenser abnormally hot 	<ul style="list-style-type: none"> Excessive refrigerant charge 	<ul style="list-style-type: none"> Recover excess refrigerant
<ul style="list-style-type: none"> Chilled water leaving temperature too high 	<ul style="list-style-type: none"> Excessive cooling load 	<ul style="list-style-type: none"> Reduce load, reduce water flow if necessary

J.- DISCHARGE PRESSURE IS TOO LOW

PROBLEMS - SYMPTOMS	PROBABLE CAUSE	RECOMMENDED ACTION
<ul style="list-style-type: none"> No sub-cooling when operating at full load. 	<ul style="list-style-type: none"> Low refrigerant charge 	<ul style="list-style-type: none"> Repair the leak and add refrigerant

K.- SUCTION PRESSURE IS TOO HIGH

PROBLEMS - SYMPTOMS	PROBABLE CAUSE	RECOMMENDED ACTION
<ul style="list-style-type: none"> The compressor runs continuously 	<ul style="list-style-type: none"> Too much cooling demand on the evaporator 	<ul style="list-style-type: none"> Check the system
<ul style="list-style-type: none"> Suction line unusually cold. Liquid refrigerant returns to compressor 	<ul style="list-style-type: none"> Expansion valve opened to far 	<ul style="list-style-type: none"> Adjust superheat and check that the expansion valve sensors are correctly fitted. Check parameters for electronic expansion valve.
	<ul style="list-style-type: none"> Expansion valve blocked in open position 	<ul style="list-style-type: none"> Repair or replace

L.- SUCTION PRESSURE IS TOO LOW

PROBLEMS - SYMPTOMS	PROBABLE CAUSE	RECOMMENDED ACTION
<ul style="list-style-type: none"> No sub-cooling when operating at full load 	<ul style="list-style-type: none"> Low refrigerant charge 	<ul style="list-style-type: none"> Repair the leak and add refrigerant
<ul style="list-style-type: none"> Excessive pressure drop across the filter-drier 	<ul style="list-style-type: none"> Filter-drier obstructed 	<ul style="list-style-type: none"> Replace the cartridge
<ul style="list-style-type: none"> Loss of capacity 	<ul style="list-style-type: none"> Expansion valve obstructed 	<ul style="list-style-type: none"> Clean or replace
<ul style="list-style-type: none"> Conditioned space too cold 	<ul style="list-style-type: none"> Control thermostat contacts stuck in closed position 	<ul style="list-style-type: none"> Repair or replace
<ul style="list-style-type: none"> Compressor short-cycling 	<ul style="list-style-type: none"> Capacity modulation setting too low 	<ul style="list-style-type: none"> Adjust
<ul style="list-style-type: none"> Low pressure drop in the evaporator 	<ul style="list-style-type: none"> Low water flow 	<ul style="list-style-type: none"> Check water flow. Check the condition of the filters, look for obstructions in the chilled water circuit piping

6.- TROUBLESHOOTING - REPAIRS

6.2.- CONTROL DEVICES

Operation

By reacting to compressor discharge pressure, the high pressure switch monitors efficiency of the condenser. Poor efficiency, the result of an excessive condensing pressure, is usually caused by:

- A dirty condenser.
- Low air flow.

The low pressure transducer monitors the pressure at which the refrigerant evaporates in the evaporator tubes. Low evaporating pressure is usually caused by:

- Low refrigerant charge.
- A faulty expansion valve.
- An obstructed liquid line filter-drier.

The control thermostat monitors chilled water temperature at the evaporator inlet. The most common causes of abnormal temperatures in this zone are:

- Low water flow.
- Thermostat setting too low.

A defective crankcase heater, causes condensation of refrigerant in the oil sump.

The above information does not represent a complete analysis of the refrigeration system. It is intended to familiarise the operator with unit operation and to provide him with the technical data required to enable him to recognise, correct or report a fault.



Only trained and qualified personnel is authorised to service and maintain this equipment.

6.- TROUBLESHOOTING - REPAIRS

6.3.- REGULAR CHECKS TO BE MADE: CHILLER UNIT ENVIRONMENT

CHILLED WATER CIRCUIT VALUE:

Inlet / Outlet pressure gauges for pressure drop	kPa
Evaporator inlet temperature	°C
Evaporator outlet temperature	°C
Glycol concentration (1)	%
Flow switch operational at	flow %
Chilled water pump interlock	[]
Filter on water circuit	[]

CONDENSER WATER CIRCUIT:

Inlet / Outlet pressure gauges for pressure drop	kPa
Condenser inlet temperature	°C
Condenser outlet temperature	°C
Regulation on condenser water inlet	[]
Condenser pump interlock	[]
Filter on water circuit	[]
Unrestricted air flow on condenser coils (2)	[]

ELECTRICAL POWER SUPPLY:

Control circuit voltage	V
Power circuit power supply voltage L1/L2	V
Power circuit power supply voltage L2/L3	V
Power circuit power supply voltage L3/L1	V

(1) Depending on the application.

(2) According to the type of unit.

6.- TROUBLESHOOTING - REPAIRS

6.4.- MANUFACTURER'S RECOMMENDED INSPECTIONS

6.4.1.- Liquid chillers with scroll compresor(s)

6.4.1.1.- Number of recommended preventive maintenance visits

NUMBER OF RECOMMENDED PREVENTIVE MAINTENANCE VISITS

Year visit	Start up Tube analysis	500 / 1000h visit	Major technical inspection	Inspection
1	1	1		2
2			1	3
3			1	3
4				3
5			1	3
6			1	3
7				3
8			1	3
9			1	3
10				3
+10				

This table is published for units operating under normal conditions with an average annual runtime of 4000 hours. In hostile industrial environments, a specific maintenance visit schedule must be planned.

(1) Depending on the quality of the water.

6.4.1.2.- Description of inspection duties

START UP:

- Check unit installation
- Check water flow and water circuit auxiliaries
- Check safety devices
- Check leak tightness
- Configuration of the microprocessor based management system
- Verification of operating parameters and unit performance
- Transmission of the machine service log

500 h / 1000 h VISITS:

- Post wear in inspection
- Oil acidity test, leak test
- Replacement of the filter-drier cartridges depending on the results of the test above.
- Monitor unit performance and any eventual variations linked to use of the installation.

INSPECTION VISIT:

- Leak test.
- Operating test with record of measurements taken and functional analysis.

MAJOR TECHNICAL INSPECTION:

- Inspection visit.
- Acid test.
- Oil change if necessary.
- Replacement of filter-drier cartridges.
- Check up on the microprocessor based management system.
- Adjustment of safety devices.
- Verification of unit interlocks.
- Lubrication of bearings / dampers if necessary.
- Check Microchannel condenser connections.



In case of a positive acidity test result, we advice to replace the oil.
In a case of high acidity level a circuit clean up is recommended.

7.- CHECK LIST

Machine identifications:	Affair number:		
Year of manufacture:			
NORMAL CONDITIONS OF USE			
Leaving chilled water temperature:	°C		
Outdoor air temperature:	Max:	°C	Min:
Power supply voltage:	V/Ph/Hz		
Refrigerant type:			
Date and time measurements were taken:			
Outdoor air temperature:	°C		
Company responsible for measurements:			
Name of technician:			
Reamrks:			

		Circuit 1			Circuit 2			Circuit 3	Circuit 4
		Compr. 1	Compr. 2	Compr. 3	Compr. 1	Compr. 2	Compr. 3	Compr. 1	Compr. 1
Number of hours of operation									
Compressors in service per circuit									
Evaporating pressure	Bar								
Suction piping temperature	°C								
Condensing pressure	Bar								
Discharge piping temperature	°C								
Oil pump temperature	°C								
Oil pressure	Bar								
Oil level									
Current on phase 1 per compressor	A								
Current on phase 2 per compressor	A								
Current on phase 3 per compressor	A								
Liquid line temperature	°C								
Evaporator pressure drop	Bar								
Chilled water temperature	°C								
Leaving chilled water temperature	°C								
Condenser pressure drop	Bar								
Condenser lentering water temperature	°C								
Condenser leaving water temperature	°C								
H.P. pressure switch cut-out	Bar								
H.P. pressure switch cut-in	Bar								
Low pressure switch cut-in	Bar								
Oil pressure switch cut-out	Bar								
Antifreeze pressure switch cut-out	Bar								

Fan pressure switch 1: (cut-out / bar)	Fan 2:	Fan 3:	Fan 4:
---	---------------	---------------	---------------

7.- CHECK LIST

This check list should be filled in by the contractor to make sure that unit installation takes place according to appropriate industry practices.

WARNING: Disconnect the power supply before carrying out any inspections on the unit. If the unit must be left powered up, proceed with precaution to avoid risk of electrocution.

RECEPTION:

- Check absence of transport damage. If the product is damaged, exact details must be reported directly to Lennox.
- Check for missing items.
- Availability of suitable lifting gear, slings and spacers.

UNIT INSTALLATION:

- Remove shipping crate.
- Confirm unit installation clearances.
- Mount vibration isolators.
- Set unit in permanent place.
- Level unit if necessary.

CHILLED WATER CIRCUIT:

- Check all piping for leakage.
- Install thermometers.
- Install water pressure regulator.
- Install balancing valves.
- Install flow switch.
- Clean, rinse, and fill water piping before connecting to the unit. Check presence of filter on unit inlet and state of cleanliness of the filter.
- Check operation of the pump and evaporator pressure drop.
- Check minimum volume of installation of hydraulic system.
- Expansion vessel is at correct pressure (before water is filled).
- If pump is external, flow rate is measured and within range.

ELECTRICAL EQUIPMENT:

- Check the main power supply matches the unit data plate.
- Check that the unit is correctly earthed.
- Check order of power supply phases for scroll compressor units.
- Check correct direction of rotation of fan motors and proper operation of the latter.
- Verify direction of rotation of pump correct.
- Ensure control cabinet wired up.
- Ensure power supply conforms with unit nameplate indications.
- Ensure pump starter and flow switch circuits complete and in working order.
- Install pipe heaters on all piping exposed to freezing temperatures.
- Tighten all connections with a torque wrench.

GENERAL:

- Ensure cooling load is available, (minimum 50 %).
- Coordination between different professions on site required for final commissioning.
- Power on carter heater 48 hour before commissioning date.

CUSTOMER ORDER NUMBER LENNOX REFERENCE:

DESIGNATION

COMMENTS:

NAME: SIGNATURE:

SALES OFFICES :

BELGIUM AND LUXEMBOURG

 + 32 3 633 3045

FRANCE

 +33 1 64 76 23 23

GERMANY

 +49 (0) 211 950 79 60

ITALY

 + 39 02 495 26 200

NETHERLANDS

 + 31 332 471 800

POLAND

 +48 22 58 48 610

PORTUGAL

 +351 229 066 050

SPAIN

 +34 915 401 810

UKRAINE

 +38 044 585 59 10

UNITED KINGDOM AND IRELAND

 +44 1604 669 100

OTHER COUNTRIES :

LENNOX DISTRIBUTION

 +33 4 72 23 20 20



Due to LENNOX EMEA ongoing commitment to quality, the specifications, ratings and dimensions are subject to change without notice and without incurring liability. Improper installation, adjustment, alteration, service or maintenance can cause property damage or personal injury. Installation and service must be performed by a qualified installer and servicing agency.



www.lennoxemea.com

MIL166E-0222 09-2024

LENNOX